



individualized  
computation

$b_2$

*answers & annotations*

**Cover Art:**  
The Second grade class of Sally Osselaer and Chris  
Bonfilio at Manzanita School.

**Art Staff:**  
CHRISTINA TROCCOLO  
JAMES HURST



©1974, CURRICULUM DEVELOPMENT ASSOCIATES, INC.  
Suite 414 • 1211 Connecticut Ave., N.W.  
Washington, D.C. 20036

A FRIENDLY MATH ASSOCIATES PROJECT  
Director  
ROBERT W. WIRTZ

Editor and General Manager:  
ROBERT BECK

Art and Production Manager:  
LIESELOTTE ESSER

BCDE-B-3210

The rule for this activity is on page 12.

Lines and Crossing Points

Líneas y Cruceros

The children may use real sticks (or toothpicks) on the diagram and count the crossing points they make with the drawn lines. You may want to have the children draw in the crossing

one way to complete

una manera de completar

A.  $\frac{2+0}{-} = \frac{2}{-}$

B.  $\frac{0+3}{-} = \frac{3}{-}$

A. points.

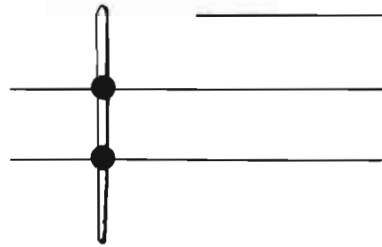

$2 + 0 = 2$

You may use toothpicks and

B.

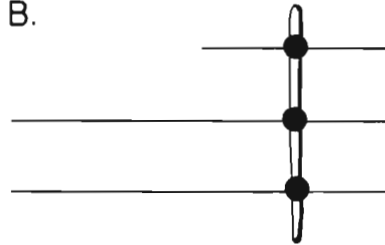

$0 + 3 = 3$

a grid with an over

C.  $\frac{4+0}{-} = \frac{-}{-}$

D.  $\frac{2+}{-} = \frac{5}{-}$

C.

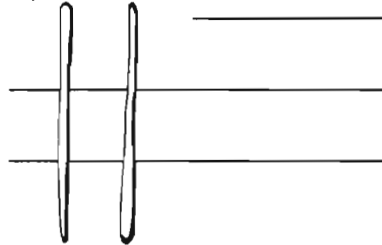

$4 + 0 = 4$

head projector to introduce

D.

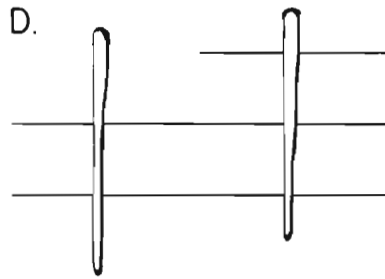

$2 + 3 = 5$

this. See also: Developing

E.  $\frac{6+0}{-} = \frac{-}{-}$

F.  $\frac{0+}{-} = \frac{6}{-}$

E.

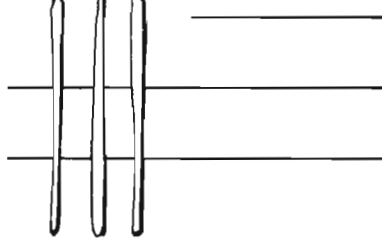

$6 + 0 = 6$

Insights pp. 113-135

F.

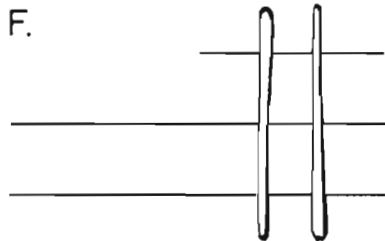

$0 + 6 = 6$

G.  $\frac{+3}{-} = \frac{7}{-}$

H.  $\frac{+}{-} = \frac{-}{-}$

G.

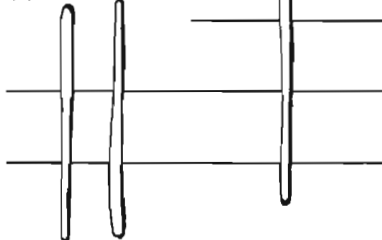

$4 + 3 = 7$

H.

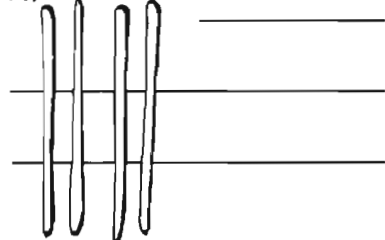

$8 + 0 = 8$

Please complete the sketches and reports.

Favor de completar los dibujos y reportes.

The children might want to continue using toothpicks for the vertical lines.

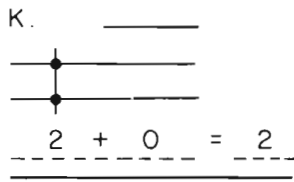
K.   
 $2 + 0 = 2$

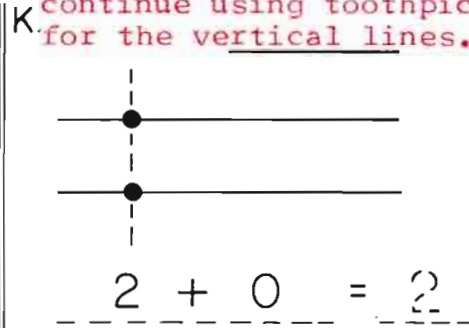
K.   
 $2 + 0 = ?$

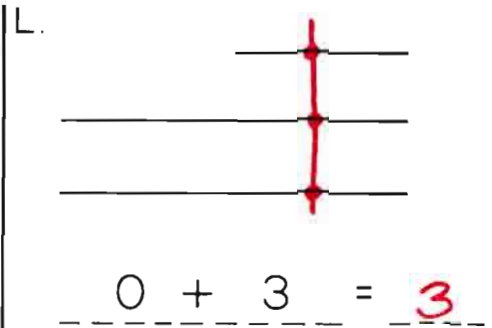
L.   
 $0 + 3 = 3$

L.   
 $0 + 3 = 3$

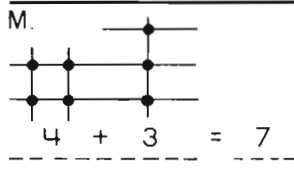
M.   
 $4 + 3 = 7$

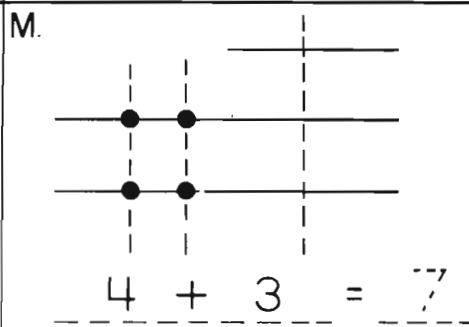
M.   
 $4 + 3 = 7$

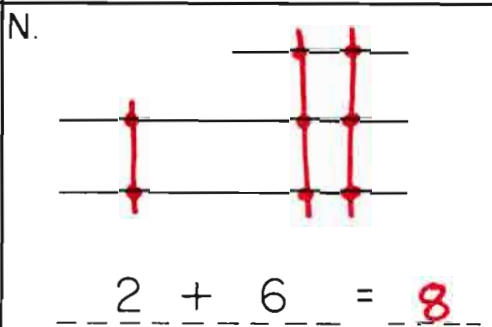
N.   
 $2 + 6 = 8$

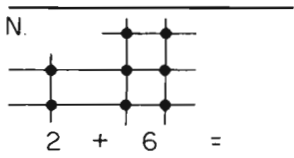
N.   
 $2 + 6 = .$

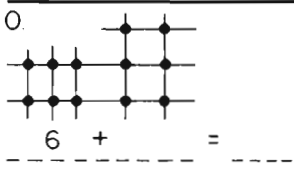
O.   
 $6 + . = .$

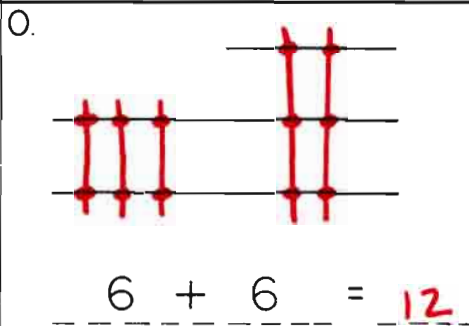
O.   
 $6 + 6 = 12$

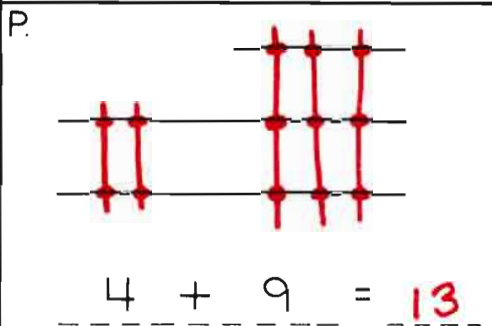
P.   
 $4 + 9 = 13$

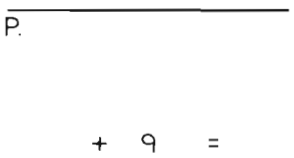
P.   
 $. + 9 = .$

Q.   
 $. = .$

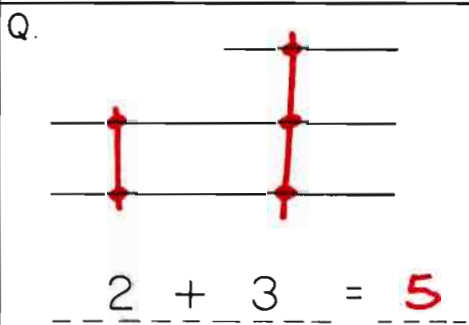
Q.   
 $2 + 3 = 5$

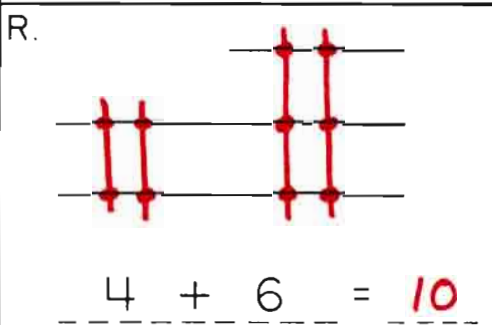
R.   
 $4 + 6 = 10$

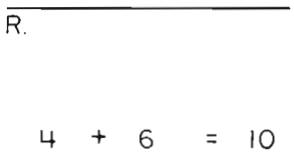
R.   
 $4 + 6 = 10$

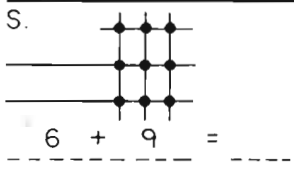
S.   
 $6 + 9 = .$

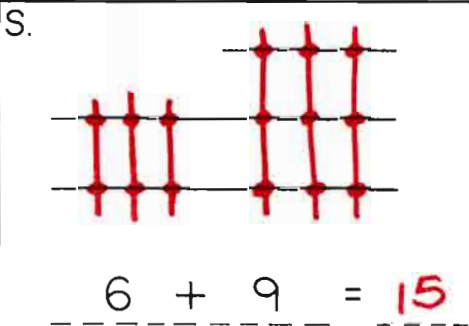
S.   
 $6 + 9 = 15$

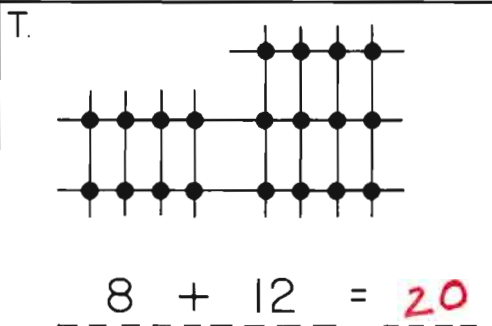
T.   
 $8 + 12 = 20$



one way to make the arrangement

una manera de arreglar los dados

A. 
$$\begin{array}{r} 1 \\ + 2 \\ \hline 3 \end{array}$$

B. 
$$\begin{array}{r} 3 \\ - 2 \\ \hline 1 \end{array}$$

C. 
$$\begin{array}{r} 2 \\ + 4 \\ \hline 6 \end{array}$$

D. 
$$\begin{array}{r} 6 \\ - \\ \hline 2 \end{array}$$

E. 
$$\begin{array}{r} 2 \\ + 5 \\ \hline \end{array}$$

F. 
$$\begin{array}{r} \\ - 5 \\ \hline 2 \end{array}$$

G. 
$$\begin{array}{r} \\ + \\ \hline 9 \end{array}$$

H. 
$$\begin{array}{r} 9 \\ - \\ \hline 3 \end{array}$$

I. 
$$\begin{array}{r} \\ + \\ \hline \end{array}$$

J. 
$$\begin{array}{r} \\ - \\ \hline 1 \end{array}$$

K. 
$$\begin{array}{r} \\ + 5 \\ \hline \end{array}$$

L. 
$$\begin{array}{r} \\ - \\ \hline \end{array}$$

Please arrange each set of boxes to show examples of addition and subtraction.

Favor de arreglar cada grupo de dados para demostrar ejemplos de sumas y restas.

See also: Patterns and Problems pp. 43-48

Drill and Practice pp. 166 - 168

A. 
$$\begin{array}{r} 1 \quad 2 \\ \hline 3 \end{array}$$

B. 
$$\begin{array}{r} 1 \quad 2 \\ \hline 3 \end{array}$$

Some problems have more than one answer.

C. 
$$\begin{array}{r} 2 \quad 4 \\ \hline 6 \end{array}$$

D. 
$$\begin{array}{r} 2 \quad 4 \\ \hline 6 \end{array}$$

E. 
$$\begin{array}{r} 5 \quad 7 \\ \hline 2 \end{array}$$

F. 
$$\begin{array}{r} 5 \quad 7 \\ \hline 2 \end{array}$$

G. 
$$\begin{array}{r} 9 \quad 3 \\ \hline 6 \end{array}$$

H. 
$$\begin{array}{r} 9 \quad 3 \\ \hline 6 \end{array}$$

I. 
$$\begin{array}{r} 1 \quad 7 \\ \hline 6 \end{array}$$

J. 
$$\begin{array}{r} 1 \quad 7 \\ \hline 6 \end{array}$$

K. 
$$\begin{array}{r} 3 \quad 8 \\ \hline 5 \end{array}$$

L. 
$$\begin{array}{r} 3 \quad 5 \\ \hline 8 \end{array}$$

Please complete the sketches and reports.

Favor de completar los dibujos y reportes.

a.



$0 + 3 = 3$

b.

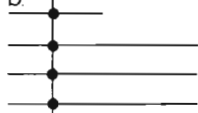

$4 + 0 = 4$

c.

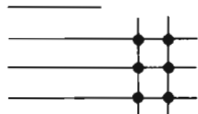

$0 + \quad = 6$

d.

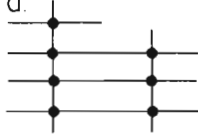

$\quad + \quad = 7$

e.



$8 + 0 = 8$

f.

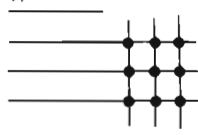

$\quad + \quad = 9$

g.

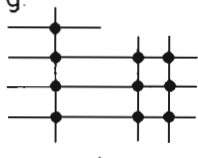

$\quad + \quad = 10$

h.

a.

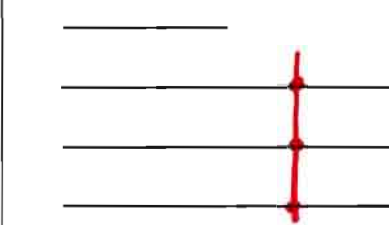

$0 + 3 = 3$

b.

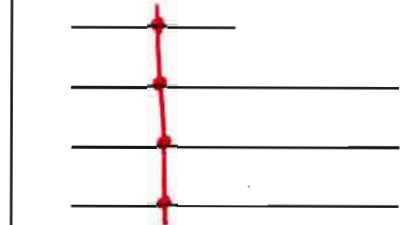

$4 + 0 = 4$

c.

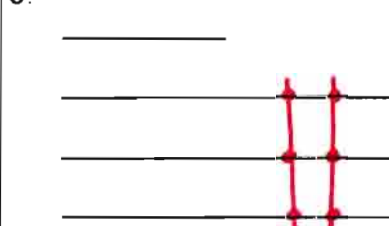

$0 + 6 = 6$

d.

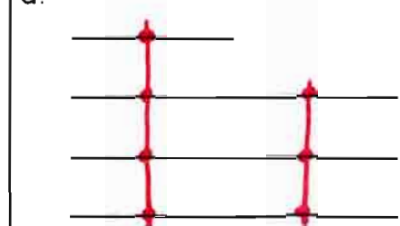

$4 + 3 = 7$

e.

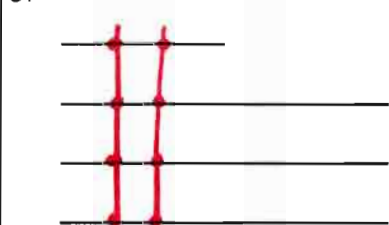

$8 + 0 = 8$

f.

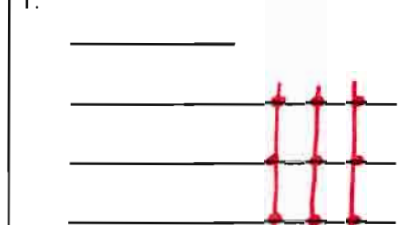

$0 + 9 = 9$

g.

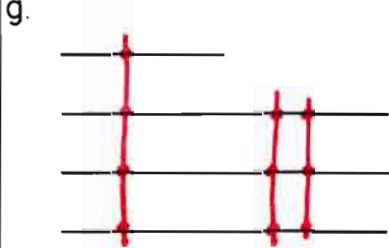

$4 + 6 = 10$

h.

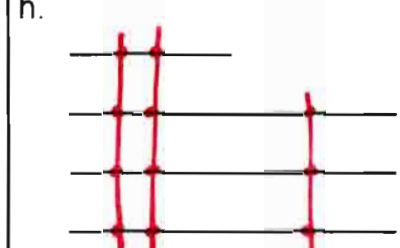

$8 + 3 = 11$

Please complete the sketches and reports.

Favor de completar los dibujos y reportes.

i.

$3 + 5 = 8$

i.

$3 + 5 = 8$

j.

$6 + 0 = 6$

j.

$+ = 6$

k.

$0 + = 10$

k.

$0 + 10 = 10$

l.

$3 + 10 = 13$

l.

$3 + = 13$

m.

$6 + 5 = 11$

m.

$6 + 5 = 11$

n.

$6 + 10 = 16$

n.

$+ = 16$

The child may want to use counters.

$4 + 3 = 7$

$6 + 6 = 12$

$6 + 9 = 15$

$2 + 3 = 5$

$4 + 9 = 13$

$4 + 6 = 10$

$2 + 6 = 8$

$8 + 3 = 11$

$6 + 5 = 11$

$0 + 9 = 9$

$3 + 5 = 8$

$6 + 10 = 16$

one way to make the arrangement.

una manera de arreglar los cuadros.

M. 
$$\begin{array}{r} \boxed{7} \\ + \boxed{5} \\ \hline \boxed{1} \boxed{2} \end{array}$$
 or 
$$\begin{array}{r} 5 \\ + 7 \\ \hline 12 \end{array}$$

N. 
$$\begin{array}{r} \boxed{1} \boxed{2} \\ - \quad \quad \\ \hline \quad \quad \boxed{7} \end{array}$$
 or 
$$\begin{array}{r} 12 \\ - 7 \\ \hline 5 \end{array}$$

O. 
$$\begin{array}{r} \boxed{7} \\ + \boxed{8} \\ \hline \quad \quad \end{array}$$
 or 
$$\begin{array}{r} 8 \\ + 7 \\ \hline 15 \end{array}$$

P. 
$$\begin{array}{r} \boxed{1} \boxed{5} \\ - \quad \quad \\ \hline \quad \quad \boxed{7} \end{array}$$
 or 
$$\begin{array}{r} 15 \\ - 8 \\ \hline 7 \end{array}$$

Q. 
$$\begin{array}{r} \boxed{8} \\ + \quad \quad \\ \hline \boxed{1} \boxed{4} \end{array}$$
 or 
$$\begin{array}{r} 6 \\ + 8 \\ \hline 14 \end{array}$$

R. 
$$\begin{array}{r} \boxed{1} \boxed{4} \\ - \quad \quad \\ \hline \quad \quad \boxed{8} \end{array}$$
 or 
$$\begin{array}{r} 14 \\ - 6 \\ \hline 8 \end{array}$$

S. 
$$\begin{array}{r} \boxed{6} \\ + \boxed{7} \\ \hline \quad \quad \end{array}$$

T. 
$$\begin{array}{r} \boxed{1} \boxed{3} \\ - \quad \quad \\ \hline \quad \quad \end{array}$$

U. 
$$\begin{array}{r} \boxed{9} \\ + \boxed{8} \\ \hline \quad \quad \end{array}$$

V. 
$$\begin{array}{r} \quad \quad \\ - \quad \quad \\ \hline \quad \quad \end{array}$$

Please arrange each set of boxes to show examples of addition and subtraction.

Favor de arreglar cada grupo de cuadros para demostrar ejemplos de sumas y restas.

M. 
$$\begin{array}{r} \boxed{1} \quad \boxed{5} \\ \quad \quad \quad \boxed{7} \\ \quad \quad + \quad \boxed{5} \\ \hline \boxed{1} \boxed{2} \end{array}$$

N. 
$$\begin{array}{r} \boxed{1} \quad \boxed{5} \\ \quad \quad \quad \boxed{1} \boxed{2} \\ \quad \quad \quad - \quad \boxed{5} \\ \hline \quad \quad \quad \boxed{7} \end{array}$$

Some problems have more than one answer.

O. 
$$\begin{array}{r} \boxed{1} \quad \boxed{5} \\ \quad \quad \quad \boxed{8} \\ \quad \quad + \quad \boxed{7} \\ \hline \boxed{1} \boxed{5} \end{array}$$

P. 
$$\begin{array}{r} \boxed{1} \quad \boxed{5} \\ \quad \quad \quad \boxed{1} \boxed{5} \\ \quad \quad \quad - \quad \boxed{8} \\ \hline \quad \quad \quad \boxed{7} \end{array}$$

Q. 
$$\begin{array}{r} \boxed{8} \quad \boxed{1} \\ \quad \quad \quad \boxed{6} \\ \quad \quad + \quad \boxed{8} \\ \hline \boxed{1} \boxed{4} \end{array}$$

R. 
$$\begin{array}{r} \boxed{8} \quad \boxed{1} \\ \quad \quad \quad \boxed{1} \boxed{4} \\ \quad \quad \quad - \quad \boxed{8} \\ \hline \quad \quad \quad \boxed{6} \end{array}$$

S. 
$$\begin{array}{r} \boxed{1} \quad \boxed{6} \\ \quad \quad \quad \boxed{7} \\ \quad \quad + \quad \boxed{6} \\ \hline \boxed{1} \boxed{3} \end{array}$$

T. 
$$\begin{array}{r} \boxed{1} \quad \boxed{6} \\ \quad \quad \quad \boxed{1} \boxed{3} \\ \quad \quad \quad - \quad \boxed{7} \\ \hline \quad \quad \quad \boxed{6} \end{array}$$

U. 
$$\begin{array}{r} \boxed{9} \quad \boxed{8} \\ \quad \quad \quad \boxed{9} \\ \quad \quad + \quad \boxed{8} \\ \hline \boxed{1} \boxed{7} \end{array}$$

V. 
$$\begin{array}{r} \boxed{9} \quad \boxed{8} \\ \quad \quad \quad \boxed{1} \boxed{7} \\ \quad \quad \quad - \quad \boxed{8} \\ \hline \quad \quad \quad \boxed{9} \end{array}$$



Please complete the sketches and reports.

Favor de completar los dibujos y reportes.

A.

$$\begin{array}{r} 3 + 7 = 10 \\ \hline \end{array}$$

B.

$$\begin{array}{r} + 7 = 13 \\ \hline \end{array}$$

A.

$$3 + 7 = 10$$

B.

$$6 + 7 = 13$$

C.

$$\begin{array}{r} 3 + \quad = 17 \\ \hline \end{array}$$

D.

$$\begin{array}{r} + 7 = 16 \\ \hline \end{array}$$

C.

$$3 + 14 = 17$$

D.

$$9 + 7 = 16$$

E.

$$\begin{array}{r} 4 + 7 = 11 \\ \hline \end{array}$$

F.

$$\begin{array}{r} + 7 = 18 \\ \hline \end{array}$$

E.

$$4 + 7 = 11$$

F.

$$4 + 14 = 18$$

G.

$$\begin{array}{r} + 7 = 15 \\ \hline \end{array}$$

H.

$$\begin{array}{r} + \quad = 14 \\ \hline \end{array}$$

G.

$$8 + 7 = 15$$

H.

$$0 + 14 = 14$$

$$\begin{array}{r} 20 \\ - 1 \\ \hline 19 \end{array}$$

$$\begin{array}{r} 20 \\ - 2 \\ \hline 18 \end{array}$$

$$\begin{array}{r} 20 \\ - 3 \\ \hline 17 \end{array}$$

$$\begin{array}{r} 20 \\ - 5 \\ \hline 15 \end{array}$$

---

$$\begin{array}{r} 20 \\ - 10 \\ \hline 10 \end{array}$$

$$\begin{array}{r} 20 \\ - 11 \\ \hline 9 \end{array}$$

$$\begin{array}{r} 20 \\ - 15 \\ \hline 5 \end{array}$$

$$\begin{array}{r} 20 \\ - 7 \\ \hline 13 \end{array}$$

A.

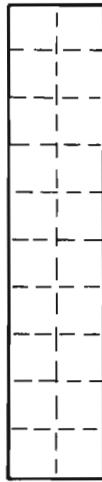

20	20	20	20
- 1	- 2	- 3	- 5
<b>19</b>	<b>18</b>	<b>17</b>	<b>15</b>

20	20	20	20
- 10	- 11	- 15	- 7
<b>10</b>	<b>9</b>	<b>5</b>	<b>13</b>

A.

$$\begin{array}{r} 25 \\ + 1 \\ \hline 26 \end{array}$$

$$\begin{array}{r} 25 \\ + 2 \\ \hline 27 \end{array}$$

$$\begin{array}{r} 25 \\ + 4 \\ \hline 29 \end{array}$$

$$\begin{array}{r} 25 \\ + 5 \\ \hline 30 \end{array}$$
  

$$\begin{array}{r} 25 \\ + 6 \\ \hline 31 \end{array}$$

$$\begin{array}{r} 25 \\ + 14 \\ \hline 39 \end{array}$$

B.

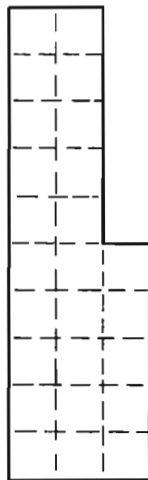

25	25	25	25
+ 1	+ 2	+ 4	+ 5
<b>26</b>	<b>27</b>	<b>29</b>	<b>30</b>

  

25	25	25	25
+ 6	+ 10	+ 14	+ 15
<b>31</b>	<b>35</b>	<b>39</b>	<b>40</b>

B.

Please make up some examples of your own.

Favor de hacer sus propios ejemplos.

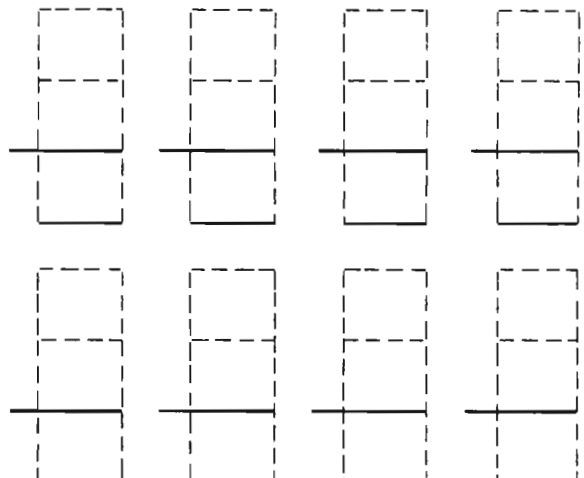
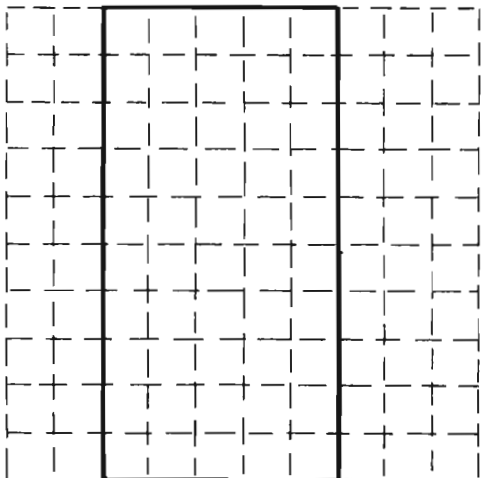

I.

$$\begin{array}{r} 0 + 16 = 16 \\ \hline \end{array}$$

J.

$$\begin{array}{r} \phantom{0} + 8 = 11 \\ \hline \end{array}$$

K.

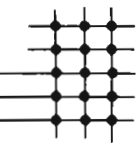

$$\begin{array}{r} \phantom{0} + 15 = 18 \\ \hline \end{array}$$

L.

$$\begin{array}{r} 9 + \phantom{0} = 19 \\ \hline \end{array}$$

I.

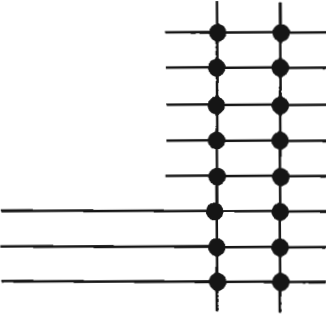

$$\begin{array}{r} 0 + 16 = 16 \\ \hline \end{array}$$

J.

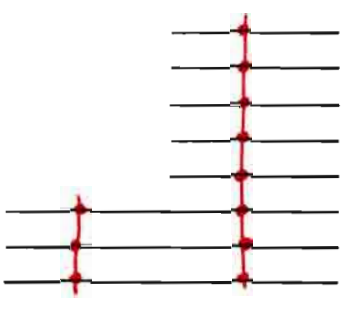

$$\begin{array}{r} 3 + 8 = 11 \\ \hline \end{array}$$

K.

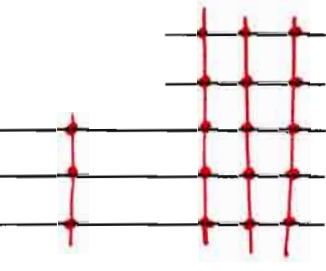

$$\begin{array}{r} 3 + 15 = 18 \\ \hline \end{array}$$

L.

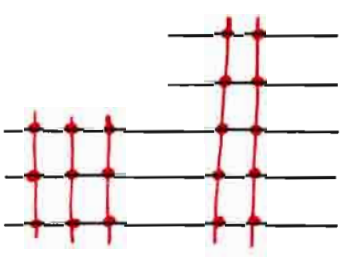

$$\begin{array}{r} 9 + 10 = 19 \\ \hline \end{array}$$

Please make up some examples of your own.

Favor de hacer sus propios ejemplos.

\_\_\_\_\_

\_\_\_\_\_

\_\_\_\_\_

$$\begin{array}{r} \phantom{0} + \phantom{0} = \phantom{0} \\ \hline \end{array}$$

\_\_\_\_\_

\_\_\_\_\_

\_\_\_\_\_

$$\begin{array}{r} \phantom{0} + \phantom{0} = \phantom{0} \\ \hline \end{array}$$

\_\_\_\_\_

\_\_\_\_\_

\_\_\_\_\_

$$\begin{array}{r} \phantom{0} + \phantom{0} = \phantom{0} \\ \hline \end{array}$$

\_\_\_\_\_

\_\_\_\_\_

\_\_\_\_\_

$$\begin{array}{r} \phantom{0} + \phantom{0} = \phantom{0} \\ \hline \end{array}$$

M.

$3 + 4 = 7$

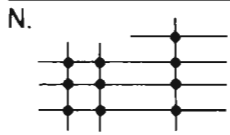

M.

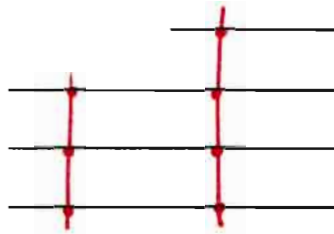

$3 + 4 = 7$

N.

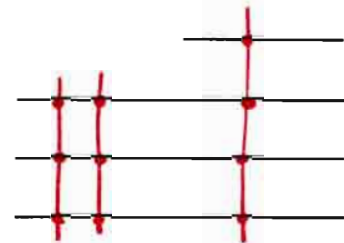

$6 + 4 = 10$

O.

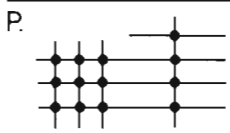
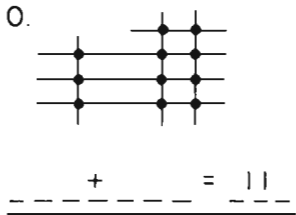

$3 + 10 = 13$

O.

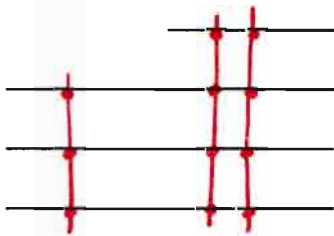

$3 + 8 = 11$

P.

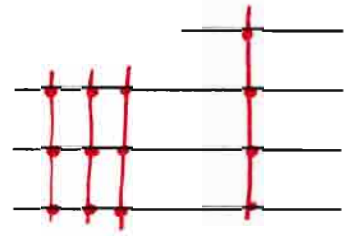

$9 + 4 = 13$

Q.

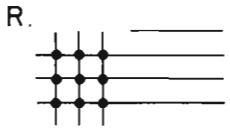
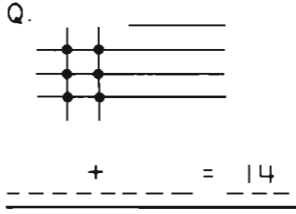

$6 + 11 = 17$

Q.

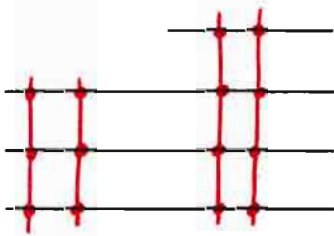

$6 + 8 = 14$

R.

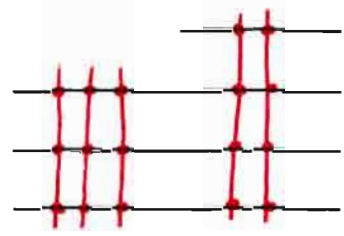

$9 + 8 = 17$

Children may want to use counters.

$4 + 3 = 7$

$8 + 5 = 13$

$9 + 7 = 16$

$6 + 5 = 11$

$6 + 7 = 13$

$6 + 8 = 14$

$3 + 8 = 11$

$4 + 14 = 18$

$9 + 5 = 14$

$3 + 7 = 10$

$4 + 7 = 11$

$8 + 7 = 15$

On Your Own

Please complete the sketches and reports.

Usted Solo

Favor de completar los dibujos y reportes.

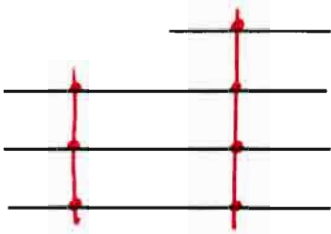

$$3 + 4 = 7$$

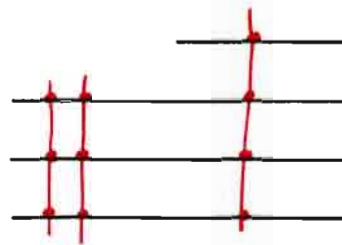

$$6 + 4 = 10$$

8
+
3
—
11

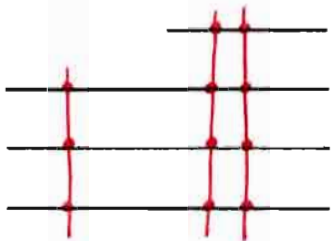

$$3 + 8 = 11$$

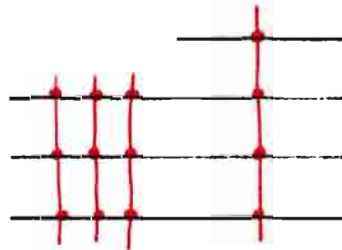

$$9 + 4 = 13$$

5
+
7
—
12

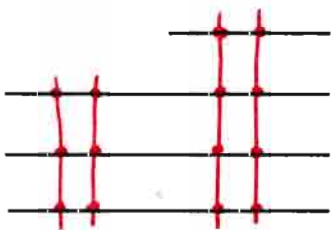

$$6 + 8 = 14$$

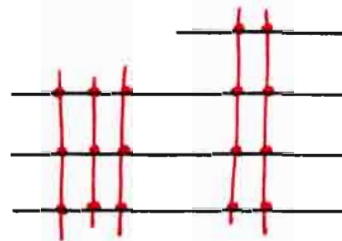

$$9 + 8 = 17$$

9
+
6
—
15

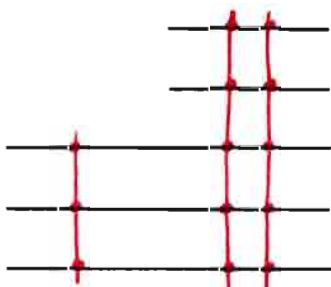

$$3 + 10 = 13$$

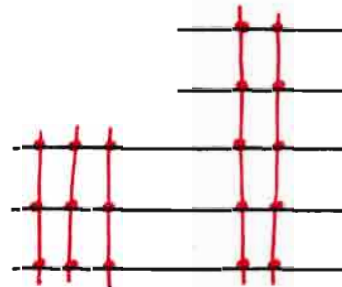

$$9 + 10 = 19$$

7
+
8
—
15



How do you feel?  
¿Cómo se siente?



Dear Parents,

The check-up exercise your child has completed on the other side of this letter is an activity derived from what we call "toothpick arithmetic." This is first introduced at the "manipulative" level - toothpicks are laid down to cross the horizontal lines given on the page. The number of crossing points then made by the sticks and lines is recorded below the sketch.

The important condition is that when a certain number of horizontal lines is given, all must be crossed if any are crossed. A diagram like:  is not allowed.

With that set of rules, problem-solving activities develop which require lots of trial and error at first.

When solving this kind of puzzle, the use of toothpicks that can be moved around without leaving painful reminders of 'errors' gives greater flexibility to the child. He is invited to experiment and to record just the correct solution. Please try some yourself and see how much mathematics and 'old-fashioned' drill you go over in your head while working them out.

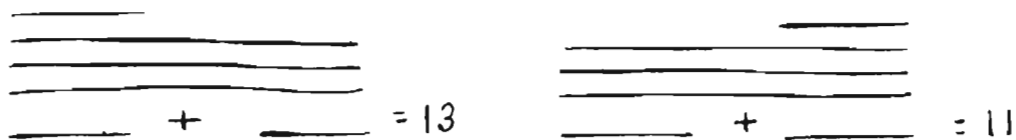
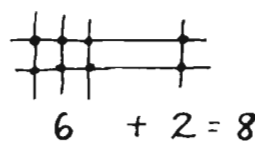

Your child has moved to the representational level now, filling in lines to create the crossing points needed to solve these interesting mathematical puzzles. Later in the book these lines and crossing points sketches will be used to deal with multiplication and division.

We hope you can see that CDA books are concerned with clearly communicating the idea that arithmetic is not just arbitrary facts and rules to memorize and parrot back, but a common way of describing and writing down what we actually find out about the "real" world. An important goal is "friendliness with numbers."

Hopefully you are becoming more friendly with numbers right along with your child, and enjoying his or her growth in mathematics. With time taken for clarity and pleasure, that growth and understanding can be so much firmer and more rewarding.

Sincerely,

Trading: a 10-stick for 10 beans

Cambiando: un palo de 10 por 10 frijoles

It is of utmost importance that prior to attempting this activity at the representational level, children have had much experience at solving similar problems with real beans and tensticks. The knowledge that, in

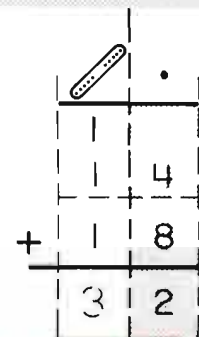
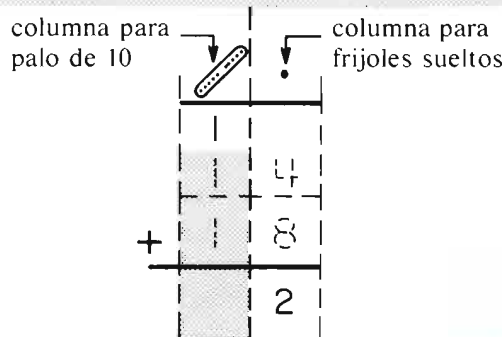
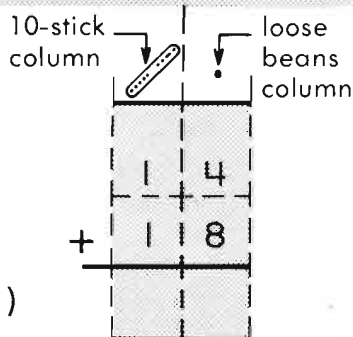
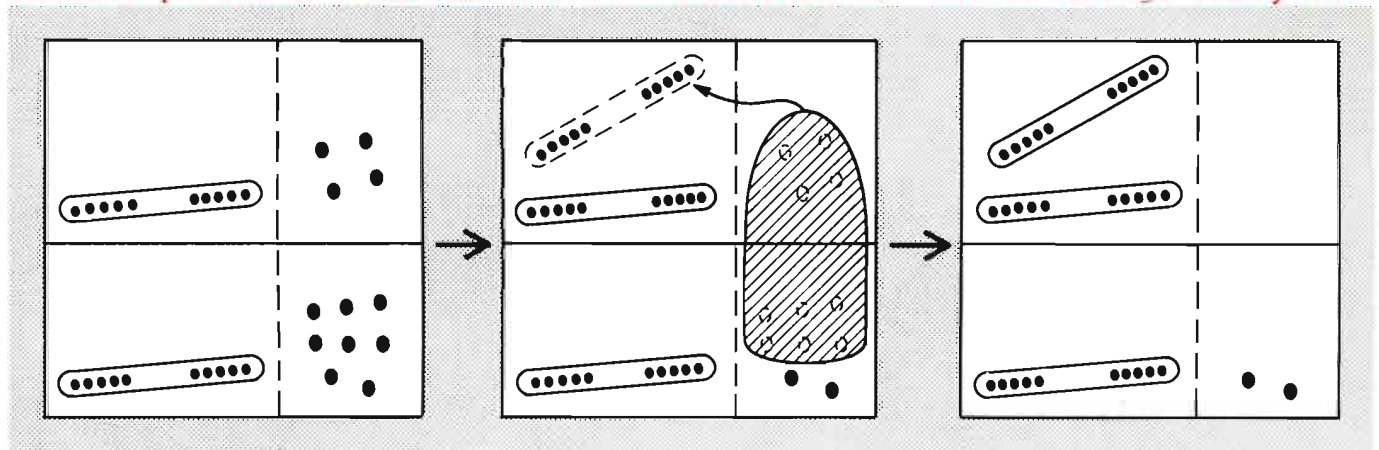

(32)

addition, ten loose beans are best managed by trading for a tenstick is vital. The easiest way to understand that is through manipulation and recording the experiment as in the examples. The references to Drill and Practice give important assistance with this.

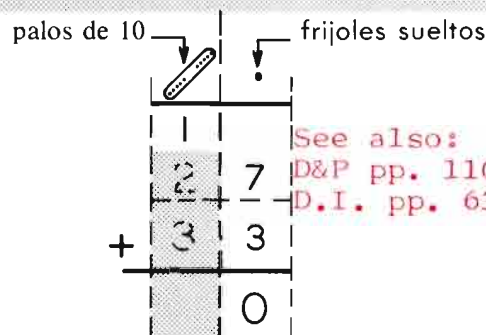
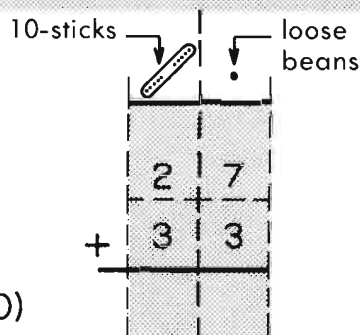
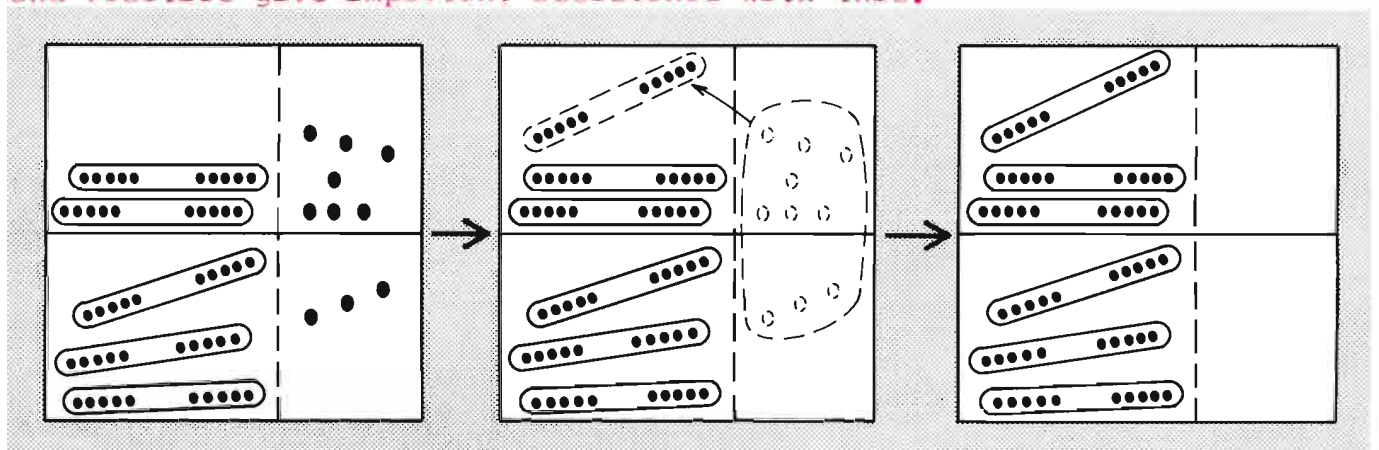

See also:  
D&P pp. 110-110D  
D.I. pp. 63-71

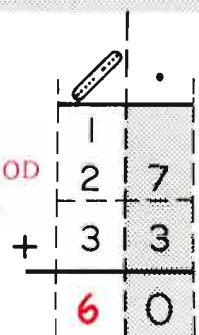

(60)

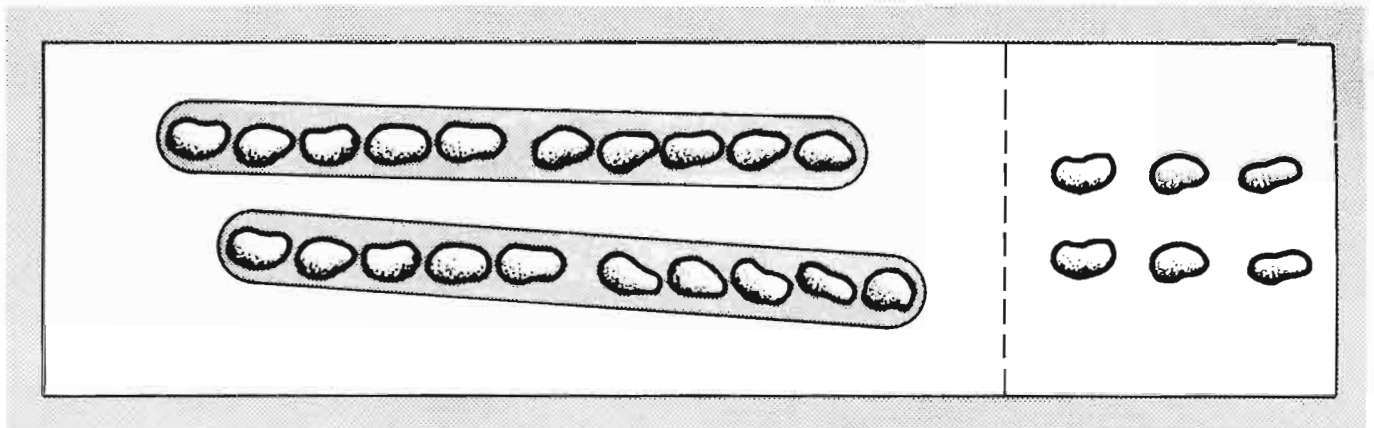

(30)	<table border="1" style="border-collapse: collapse; width: 60px; height: 60px; margin: auto;"> <tr><td style="text-align: center;">/</td><td style="text-align: center;">.</td></tr> <tr><td style="text-align: center;">2</td><td style="text-align: center;">6</td></tr> <tr><td colspan="2" style="text-align: center;">+     4</td></tr> <tr><td style="text-align: center;">3</td><td style="text-align: center;">0</td></tr> </table>	/	.	2	6	+     4		3	0	<table border="1" style="border-collapse: collapse; width: 60px; height: 60px; margin: auto;"> <tr><td style="text-align: center;">/</td><td style="text-align: center;">.</td></tr> <tr><td style="text-align: center;">2</td><td style="text-align: center;">6</td></tr> <tr><td colspan="2" style="text-align: center;">+     5</td></tr> <tr><td style="text-align: center;">4</td><td style="text-align: center;">1</td></tr> </table>	/	.	2	6	+     5		4	1	<table border="1" style="border-collapse: collapse; width: 60px; height: 60px; margin: auto;"> <tr><td style="text-align: center;">/</td><td style="text-align: center;">.</td></tr> <tr><td style="text-align: center;">2</td><td style="text-align: center;">6</td></tr> <tr><td colspan="2" style="text-align: center;">+     3</td></tr> <tr><td style="text-align: center;">3</td><td style="text-align: center;">9</td></tr> </table>	/	.	2	6	+     3		3	9
/	.																										
2	6																										
+     4																											
3	0																										
/	.																										
2	6																										
+     5																											
4	1																										
/	.																										
2	6																										
+     3																											
3	9																										
( )																											
(39)																											
( )																											

If the pictures aren't enough to help the child do this page, then you will likely have to move back to additional manipulative activities. Tensticks and loose beans to exchange, regroup etc.

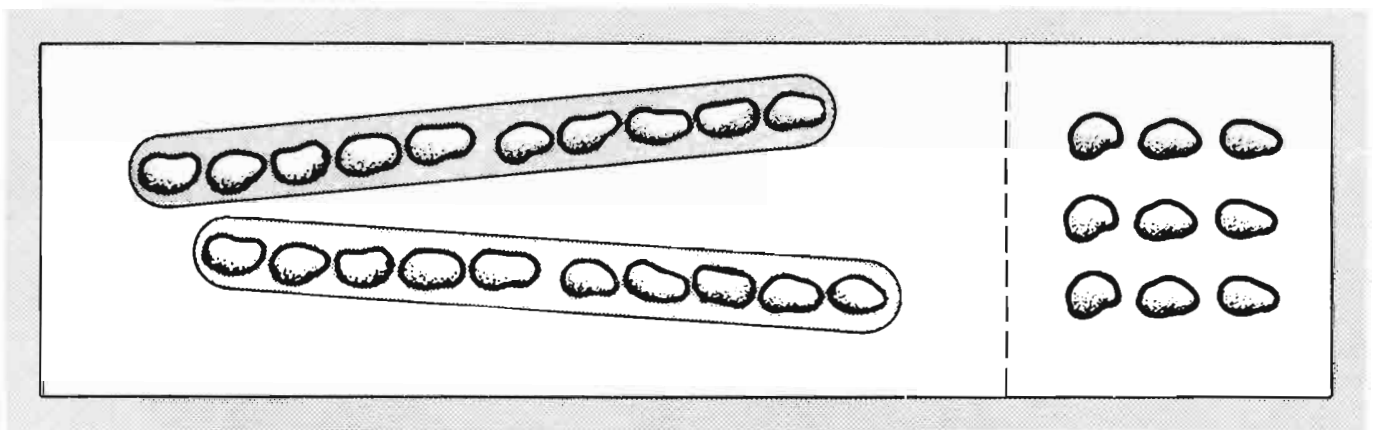

(39)	<table border="1" style="border-collapse: collapse; width: 60px; height: 60px; margin: auto;"> <tr><td style="text-align: center;">/</td><td style="text-align: center;">.</td></tr> <tr><td style="text-align: center;">2</td><td style="text-align: center;">9</td></tr> <tr><td colspan="2" style="text-align: center;">+     0</td></tr> <tr><td style="text-align: center;">3</td><td style="text-align: center;">9</td></tr> </table>	/	.	2	9	+     0		3	9	<table border="1" style="border-collapse: collapse; width: 60px; height: 60px; margin: auto;"> <tr><td style="text-align: center;">/</td><td style="text-align: center;">.</td></tr> <tr><td style="text-align: center;">2</td><td style="text-align: center;">9</td></tr> <tr><td colspan="2" style="text-align: center;">+     1</td></tr> <tr><td style="text-align: center;">4</td><td style="text-align: center;">0</td></tr> </table>	/	.	2	9	+     1		4	0	<table border="1" style="border-collapse: collapse; width: 60px; height: 60px; margin: auto;"> <tr><td style="text-align: center;">/</td><td style="text-align: center;">.</td></tr> <tr><td style="text-align: center;">2</td><td style="text-align: center;">9</td></tr> <tr><td colspan="2" style="text-align: center;">+     3</td></tr> <tr><td style="text-align: center;">5</td><td style="text-align: center;">2</td></tr> </table>	/	.	2	9	+     3		5	2
/	.																										
2	9																										
+     0																											
3	9																										
/	.																										
2	9																										
+     1																											
4	0																										
/	.																										
2	9																										
+     3																											
5	2																										
(40)																											
( )																											
( )																											

Please use 10-sticks and loose beans making up your own examples.

Favor de usar palos de 10 y frijoles sueltos cuando haga sus propios ejemplos.

10-sticks

palos de 10

loose beans  
frijoles sueltos

This space is available for children to manipulate their own beans and tensticks as they make up their own examples or solve the ones given on pages following.

10-sticks loose beans

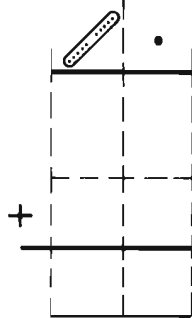
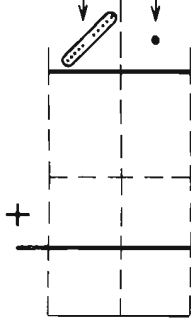

palos de 10 frijoles sueltos

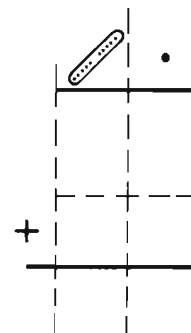
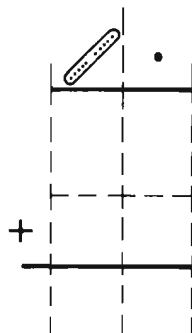
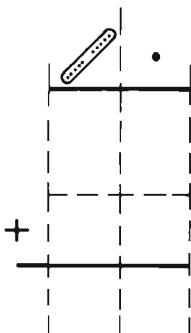
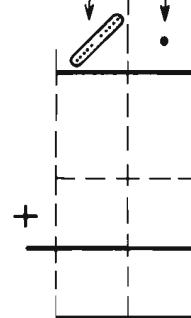



This page is presented to help children to better visualize the < > signs.

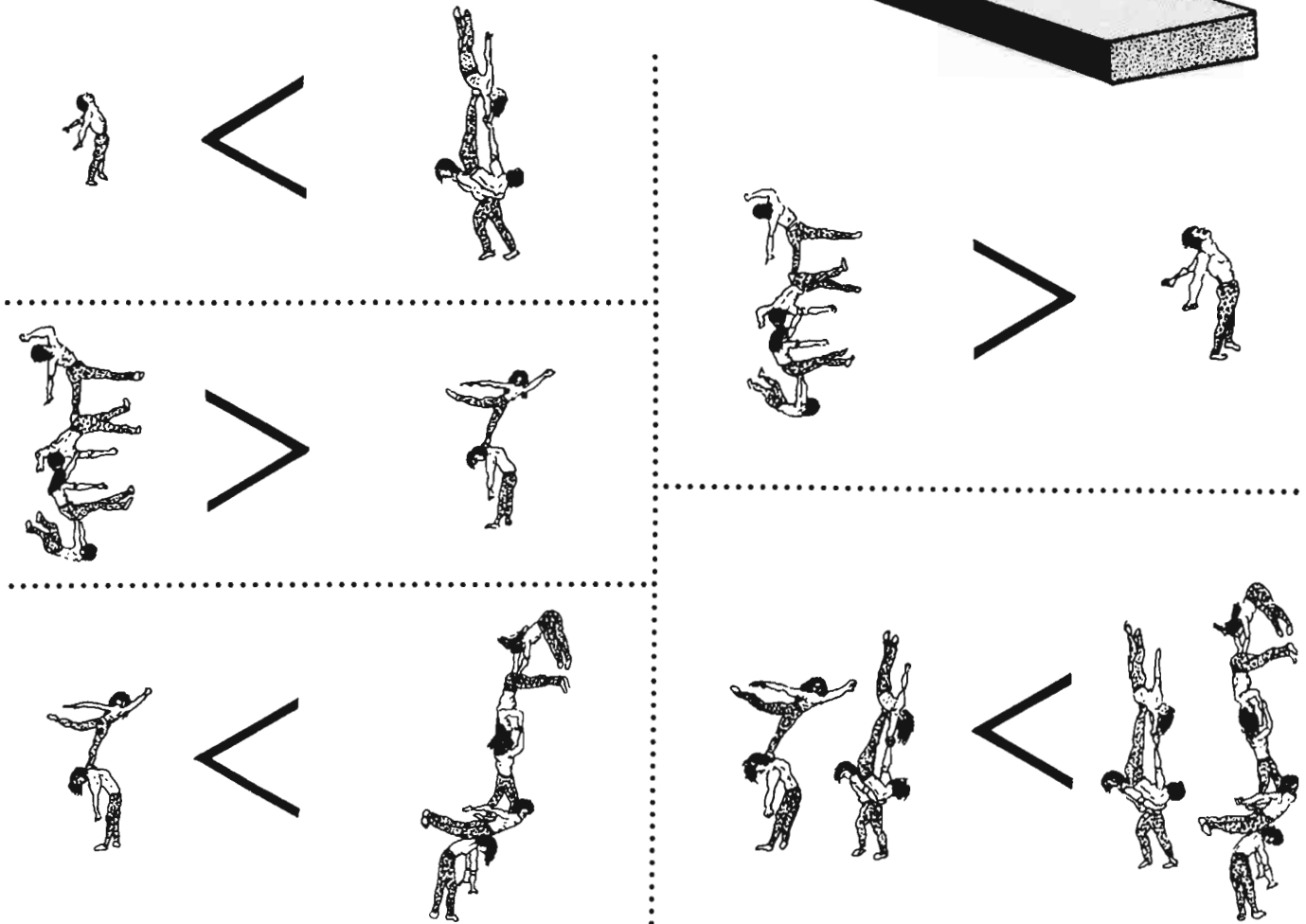
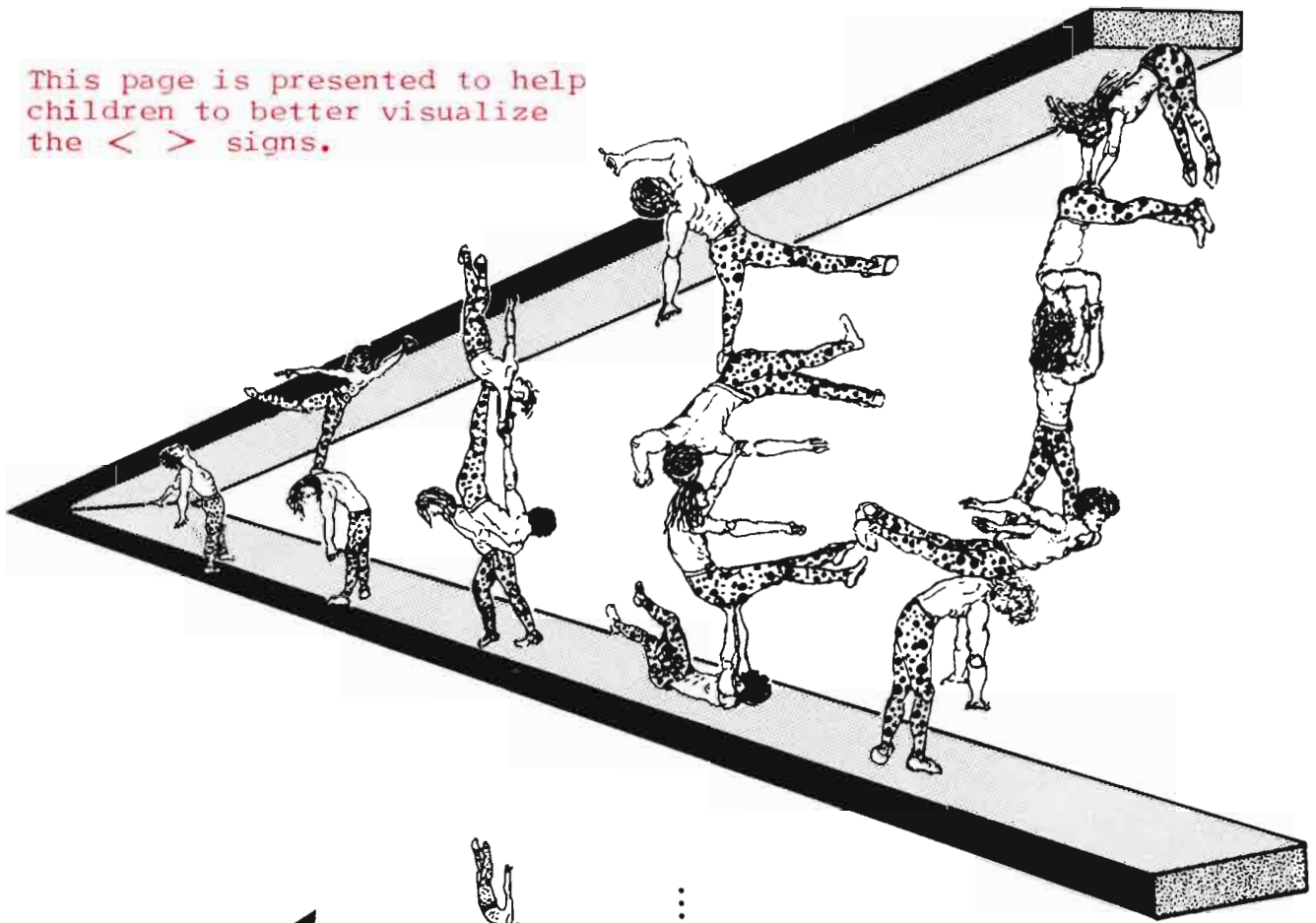



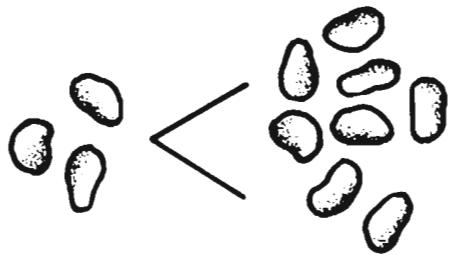
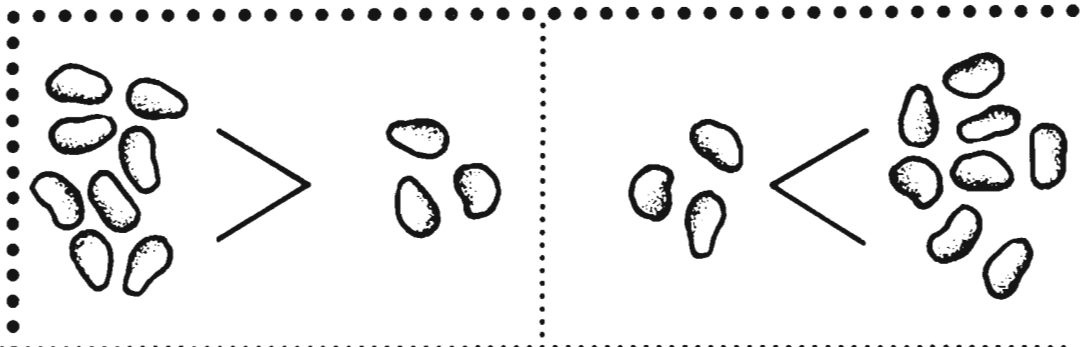
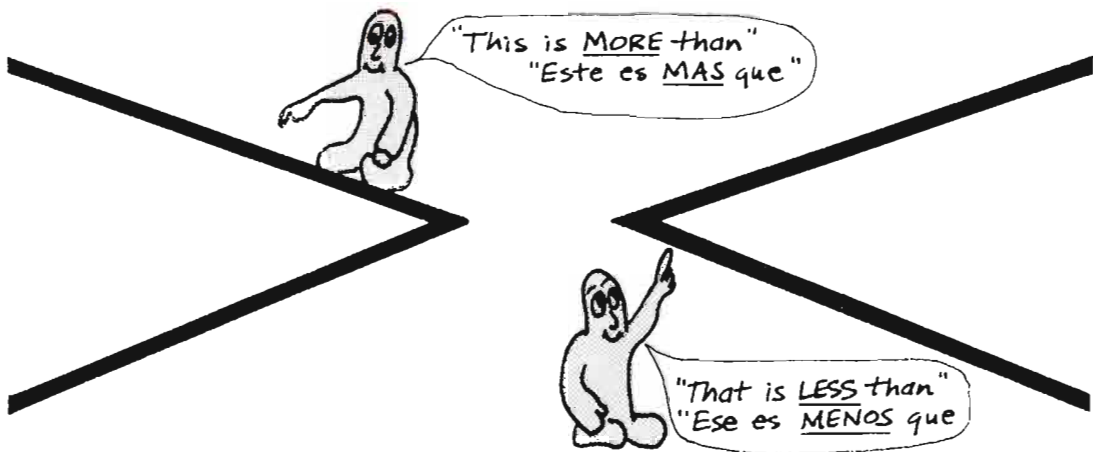

A. 3 < 6

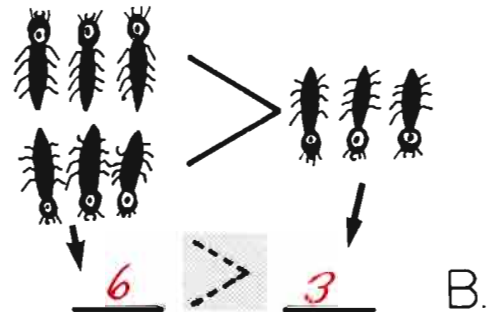
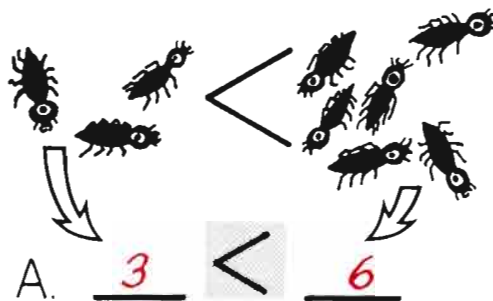

B. 6 > 3

A. 3 < 6

6 > 3 B.

C. 7 > 3

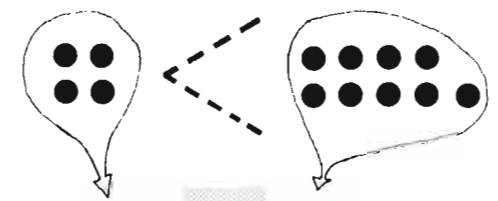

D. 4 < 9

C. 7 > 3

4 < 9 D.

E. 2 < 5

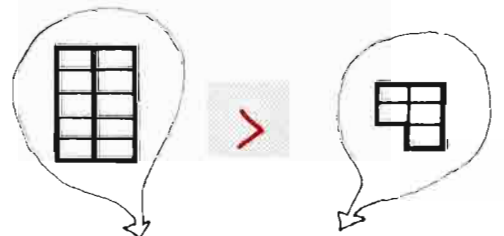
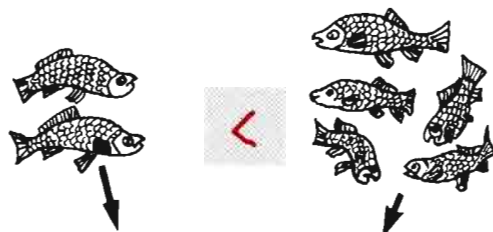

F. 10 > 5

E. 2 < 5

10 > 5 F.

Please use 10-sticks and loose beans

Favor de usar palos de 10 y frijoles sueltos

10-sticks	palos de 10	loose beans frijoles sueltos

10-sticks      loose beans

$$\begin{array}{r}
 (28) \quad \begin{array}{|c|c|} \hline 1 & 3 \\ \hline \end{array} \\
 (30) \quad + \begin{array}{|c|c|} \hline 1 & 5 \\ \hline \end{array} \\
 ( ) \quad \hline \begin{array}{|c|c|} \hline 2 & 8 \\ \hline \end{array}
 \end{array}$$

palos de 10      frijoles sueltos

$$\begin{array}{r}
 \begin{array}{|c|c|} \hline 1 & 5 \\ \hline \end{array} \\
 + \begin{array}{|c|c|} \hline 1 & 5 \\ \hline \end{array} \\
 \hline \begin{array}{|c|c|} \hline 3 & 0 \\ \hline \end{array}
 \end{array}$$

$$\begin{array}{r}
 \begin{array}{|c|c|} \hline 3 & 5 \\ \hline \end{array} \\
 + \begin{array}{|c|c|} \hline 4 & 7 \\ \hline \end{array} \\
 \hline \begin{array}{|c|c|} \hline 8 & 2 \\ \hline \end{array}
 \end{array}$$

$$\begin{array}{r}
 (72) \quad \begin{array}{|c|c|} \hline 3 & 6 \\ \hline \end{array} \\
 ( ) \quad + \begin{array}{|c|c|} \hline 3 & 6 \\ \hline \end{array} \\
 ( ) \quad \hline \begin{array}{|c|c|} \hline 7 & 2 \\ \hline \end{array}
 \end{array}$$

$$\begin{array}{r}
 \begin{array}{|c|c|} \hline 2 & 8 \\ \hline \end{array} \\
 + \begin{array}{|c|c|} \hline 4 & 5 \\ \hline \end{array} \\
 \hline \begin{array}{|c|c|} \hline 7 & 3 \\ \hline \end{array}
 \end{array}$$

$$\begin{array}{r}
 \begin{array}{|c|c|} \hline 4 & 5 \\ \hline \end{array} \\
 + \begin{array}{|c|c|} \hline 2 & 3 \\ \hline \end{array} \\
 \hline \begin{array}{|c|c|} \hline 6 & 8 \\ \hline \end{array}
 \end{array}$$

Please use 10-sticks and loose beans making up your own examples.

Favor de usar palos de 10 y frijoles sueltos cuando haga sus propios ejemplos.

10-sticks	palos de 10	loose beans frijoles sueltos

10-sticks      loose beans

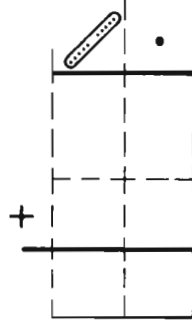
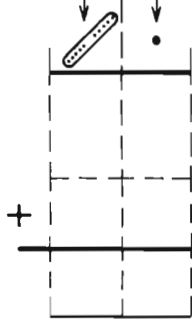

palos de 10      frijoles sueltos

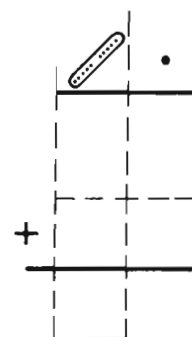
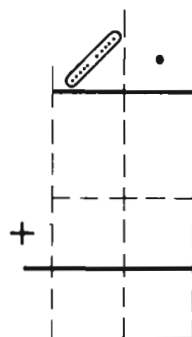
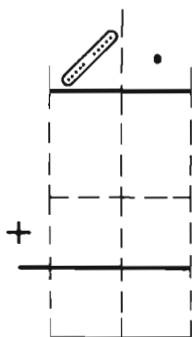
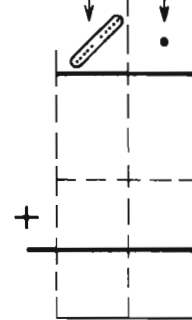



10 < 12

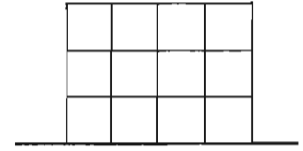
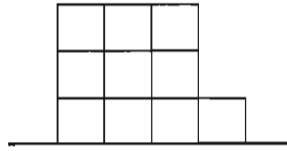

10 < 12

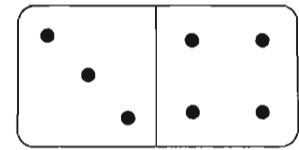
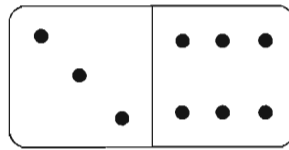

9 > 7

9 > 7

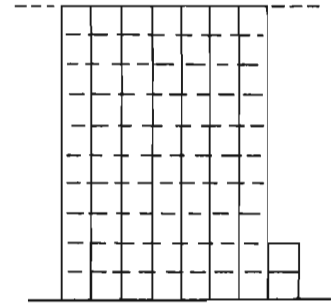
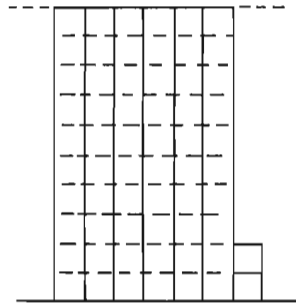

< 72

62 < 72

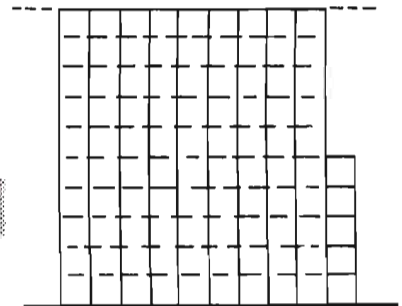
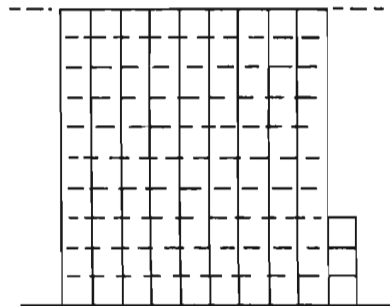

93 <

93 < 95

$12 - 3$   $>$   $12 - 5$

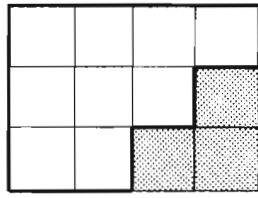

$12 - 3$

$>$

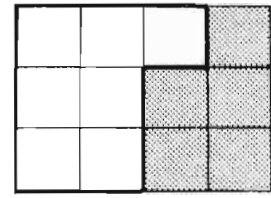

$12 - 5$

$15 - 4$   $<$

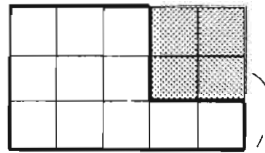

$15 - 4$

$<$

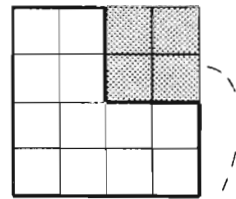

$16 - 4$

$+ 15$   $>$   $52 - 15$

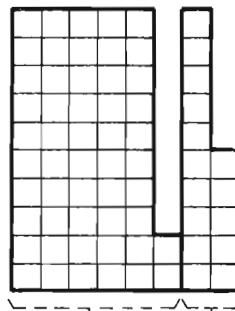

$52 + 15$

$>$

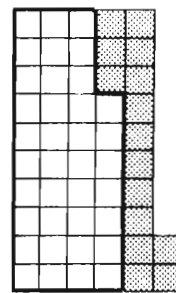

$52 - 15$

$100 - 1$   $<$   $100 + 1$

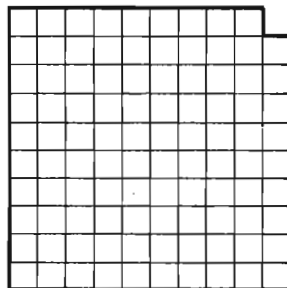

$100 - 1$

$<$

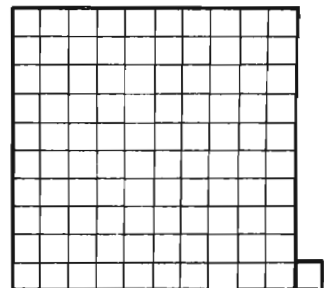

$100 + 1$



Please use 10-sticks and loose beans

Favor de usar palos de 10 y frijoles sueltos

10-sticks

palos de 10

loose beans  
frijoles sueltos

10-sticks loose beans

$$\begin{array}{r}
 \text{(34)} \\
 \text{(40)} + \\
 \hline
 \text{( )}
 \end{array}
 \begin{array}{|c|c|}
 \hline
 \text{1} & \text{7} \\
 \hline
 \text{1} & \text{7} \\
 \hline
 \text{3} & \text{4} \\
 \hline
 \end{array}$$

$$\begin{array}{r}
 \text{(25)} \\
 \text{(15)} + \\
 \hline
 \text{(40)}
 \end{array}
 \begin{array}{|c|c|}
 \hline
 \text{2} & \text{5} \\
 \hline
 \text{1} & \text{5} \\
 \hline
 \text{4} & \text{0} \\
 \hline
 \end{array}$$

palos de 10 frijoles sueltos

$$\begin{array}{r}
 \text{(18)} \\
 \text{(14)} + \\
 \hline
 \text{(32)}
 \end{array}
 \begin{array}{|c|c|}
 \hline
 \text{1} & \text{8} \\
 \hline
 \text{1} & \text{4} \\
 \hline
 \text{3} & \text{2} \\
 \hline
 \end{array}$$

$$\begin{array}{r}
 \text{(42)} \\
 \text{( )} + \\
 \hline
 \text{( )}
 \end{array}
 \begin{array}{|c|c|}
 \hline
 \text{1} & \text{3} \\
 \hline
 \text{2} & \text{9} \\
 \hline
 \text{4} & \text{2} \\
 \hline
 \end{array}$$

$$\begin{array}{r}
 \text{(26)} \\
 \text{(25)} + \\
 \hline
 \text{(51)}
 \end{array}
 \begin{array}{|c|c|}
 \hline
 \text{2} & \text{6} \\
 \hline
 \text{2} & \text{5} \\
 \hline
 \text{5} & \text{1} \\
 \hline
 \end{array}$$

$$\begin{array}{r}
 \text{(21)} \\
 \text{(19)} + \\
 \hline
 \text{(40)}
 \end{array}
 \begin{array}{|c|c|}
 \hline
 \text{2} & \text{1} \\
 \hline
 \text{1} & \text{9} \\
 \hline
 \text{4} & \text{0} \\
 \hline
 \end{array}$$



Dear Parents,

In completing the check-up exercise on the other side of this letter your child has successfully used the shorthand forms for "more than" and "less than", which are universal mathematical symbols. Before ever seeing these symbols your child certainly understood the "concept" of more and less (you've witnessed this often - "Hey, she got two more than I did!"), but now there is also a familiarity with the mathematical signs. The problems at the bottom of the page also required addition and subtraction problem-solving without any direct pictorial representation on the page. Some special praise for your young one!

As you may have already seen on previous pages coming home, your child has taken a major new step in learning to solve addition problems where "regrouping" (what we knew as "carrying") is necessary. This requires a solid understanding of the "place value" of numbers - of tens and ones in our decimal number system. We've approached this at the manipulative level with tensticks and loose beans - have you still got some handy?

Once your child can quickly show you 2 tensticks and 4 loose beans (instead of 24 loose beans) when you ask to "see" 24, then regrouping can be explored. We encourage you to go over some at home, using the tensticks and loose beans to "feel" along with your child what is actually happening in this process. You'll delight in the clarity of discovering the "concrete" relationship at a personal level too, we think!

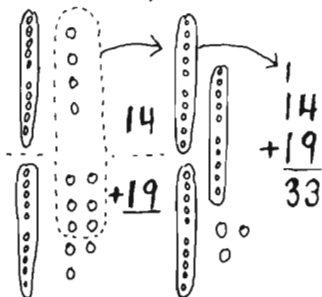

You can lay out a problem with the tensticks and beans. Adding the ones (loose beans) first, when you get to ten, "trade" them for a tenstick, and mark that you now have one more ten in the tens column. Record in the ones column how many loose beans remain, and finally the total of tens.

Again we remind you to do such activities only when you and your child can both do so in a friendly, fun way. Please remember that pleasure and self-confidence assist in the learning process more than anything else. We can't thank you enough for your help!

Sincerely,

Trading: a 10-stick for 10 beans

Cambiando: un palo de 10 por 10 frijoles

Many children have difficulty in making the transition from "regrouping" in addition to "regrouping" in subtraction. It's important at this point to insure through using real tensticks and loose beans that the children

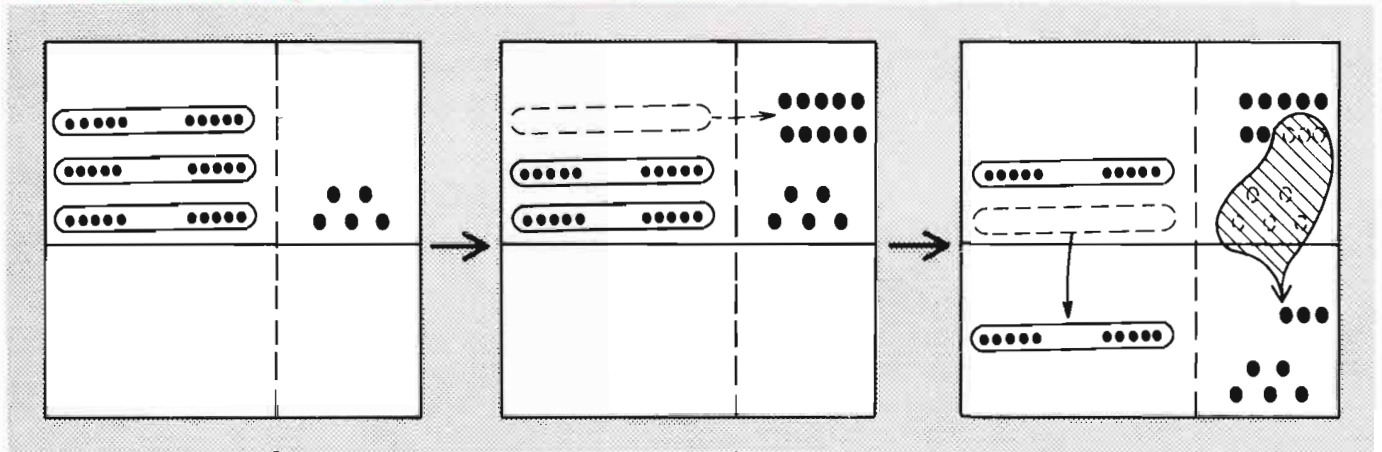

10-sticks loose beans

palos de 10 frijoles sueltos

(17)

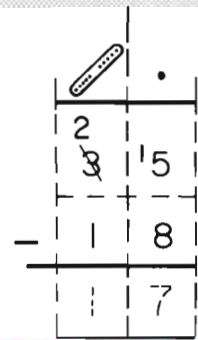
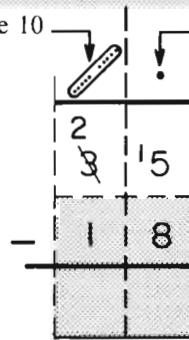
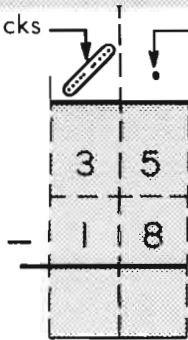

recognize the need to regroup a tenstick into 10 loose beans, and that they know how to make the exchange. They also need to know, as in the case of problems on this page, how to combine the 10 loose beans with the ones they already had.

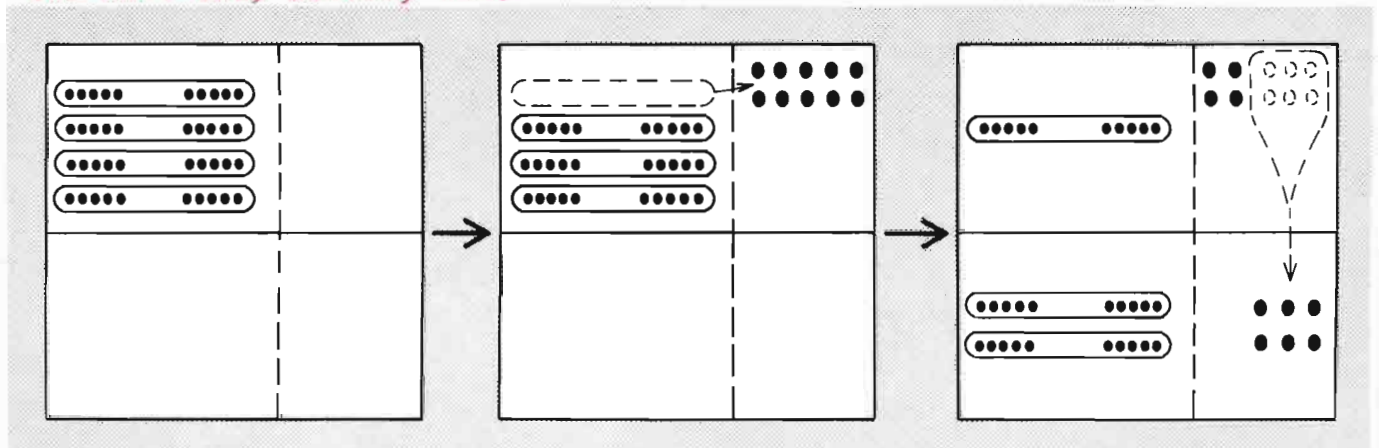

10-sticks loose beans

palos de 10 frijoles sueltos

(14)

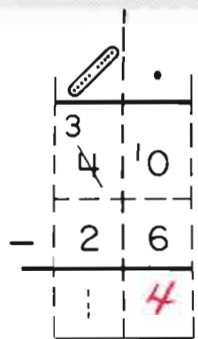
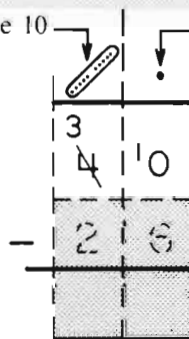
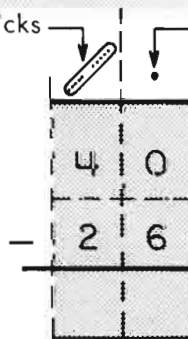

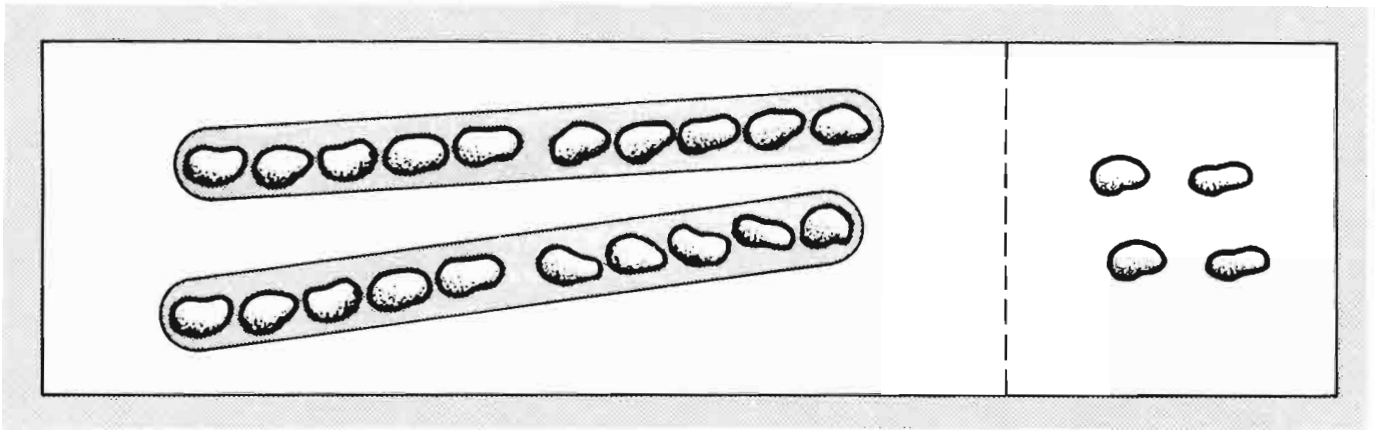

(13)				
( 9 )	$\begin{array}{r} \text{.} \\ 2 \quad 4 \\ - 1 \quad 1 \\ \hline 1 \quad 3 \end{array}$	$\begin{array}{r} \text{.} \\ \cancel{2} \quad 4 \\ - 1 \quad 5 \\ \hline \quad 9 \end{array}$	$\begin{array}{r} \text{.} \\ \cancel{2} \quad 4 \\ - \quad 7 \\ \hline 1 \quad 7 \end{array}$	$\begin{array}{r} \text{.} \\ \cancel{2} \quad 4 \\ - 1 \quad 8 \\ \hline \quad 6 \end{array}$
( )				
( )				

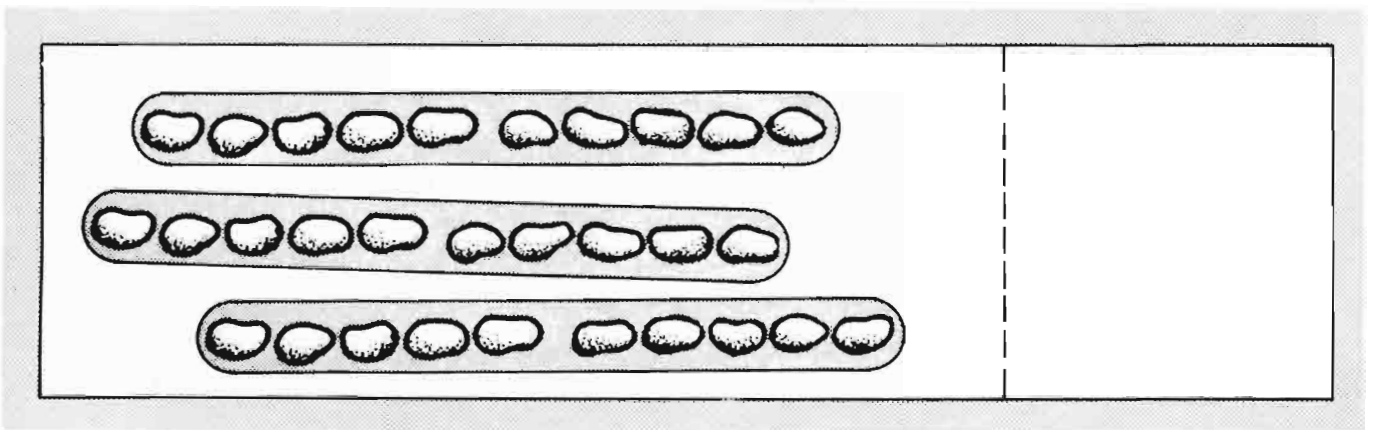

(13)				
( )	$\begin{array}{r} \text{.} \\ 2 \quad 0 \\ - 1 \quad 7 \\ \hline 1 \quad 3 \end{array}$	$\begin{array}{r} \text{.} \\ \cancel{2} \quad 0 \\ - \quad 5 \\ \hline 2 \quad 5 \end{array}$	$\begin{array}{r} \text{.} \\ 3 \quad 0 \\ - 1 \quad 0 \\ \hline 2 \quad 0 \end{array}$	$\begin{array}{r} \text{.} \\ \cancel{2} \quad 0 \\ - 2 \quad 2 \\ \hline \quad 8 \end{array}$
( )				
( )				



Please use 10-sticks and loose beans making up your own examples.

Favor de usar palos de 10 y frijoles sueltos cuando haga sus propios ejemplos.

10-sticks

palos de 10

loose beans  
frijoles sueltos

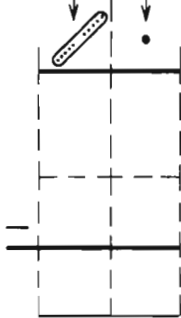

10-sticks      loose beans

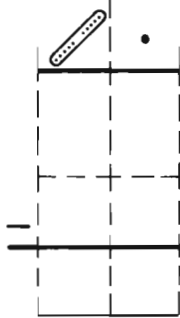

palos de 10      frijoles sueltos

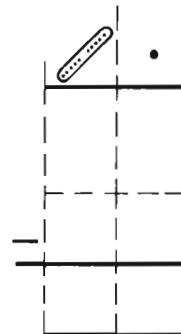
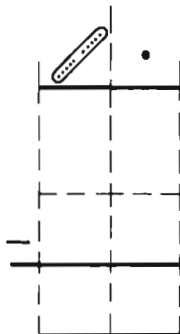
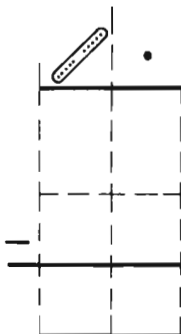
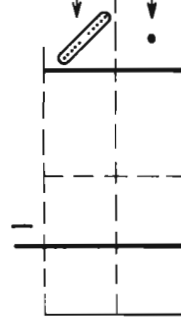

palos de 10      frijoles sueltos





one way to make the arrangement.

una manera de arreglar los cuadros.

a. 
$$\begin{array}{|c|c|} \hline 1 & 6 \\ \hline + & 7 \\ \hline \hline 2 & 3 \\ \hline \end{array}$$
 or 
$$\begin{array}{|c|} \hline 17 \\ \hline +6 \\ \hline \hline 23 \\ \hline \end{array}$$

b. 
$$\begin{array}{|c|c|} \hline 2 & 3 \\ \hline - & 7 \\ \hline \hline 1 & 6 \\ \hline \end{array}$$
 or 
$$\begin{array}{|c|} \hline 23 \\ \hline -6 \\ \hline \hline 17 \\ \hline \end{array}$$

c. 
$$\begin{array}{|c|c|} \hline 2 & 9 \\ \hline + & 1 \\ \hline \hline 3 & 0 \\ \hline \end{array}$$
 or 
$$\begin{array}{|c|} \hline 21 \\ \hline +9 \\ \hline \hline 30 \\ \hline \end{array}$$

d. 
$$\begin{array}{|c|c|} \hline 2 & 0 \\ \hline - & 9 \\ \hline \hline 2 & 1 \\ \hline \end{array}$$
 or 
$$\begin{array}{|c|} \hline 20 \\ \hline -9 \\ \hline \hline 29 \\ \hline \end{array}$$

e. 
$$\begin{array}{|c|c|} \hline 2 & 4 \\ \hline + & \\ \hline \hline 3 & 0 \\ \hline \end{array}$$

f. 
$$\begin{array}{|c|c|} \hline 3 & 0 \\ \hline - & \\ \hline \hline 2 & 6 \\ \hline \end{array}$$

g. 
$$\begin{array}{|c|c|} \hline & \\ \hline + & 4 \\ \hline \hline 3 & 1 \\ \hline \end{array}$$

h. 
$$\begin{array}{|c|c|} \hline 3 & 1 \\ \hline - & \\ \hline \hline & \\ \hline \end{array}$$

i. 
$$\begin{array}{|c|c|} \hline 2 & 9 \\ \hline + & \\ \hline \hline 3 & \\ \hline \end{array}$$

Please arrange each set of boxes to show examples of addition and subtraction.

Favor de arreglar cada grupo de cuadros para demostrar ejemplos de sumas y restas.

See also: D&P pp. 166-168

a. 
$$\begin{array}{|c|c|} \hline 1 & 6 \\ \hline + & 7 \\ \hline \hline 2 & 3 \\ \hline \end{array}$$

b. 
$$\begin{array}{|c|c|} \hline 2 & 3 \\ \hline - & 7 \\ \hline \hline 1 & 6 \\ \hline \end{array}$$

c. 
$$\begin{array}{|c|c|} \hline 2 & 9 \\ \hline + & 1 \\ \hline \hline 3 & 0 \\ \hline \end{array}$$

d. 
$$\begin{array}{|c|c|} \hline 2 & 0 \\ \hline - & 9 \\ \hline \hline 2 & 1 \\ \hline \end{array}$$

Some problems have more than one answer.

e. 
$$\begin{array}{|c|c|} \hline 2 & 4 \\ \hline + & 6 \\ \hline \hline 3 & 0 \\ \hline \end{array}$$

f. 
$$\begin{array}{|c|c|} \hline 2 & 0 \\ \hline - & 4 \\ \hline \hline 2 & 6 \\ \hline \end{array}$$

g. 
$$\begin{array}{|c|c|} \hline 2 & 7 \\ \hline + & 4 \\ \hline \hline 3 & 1 \\ \hline \end{array}$$

h. 
$$\begin{array}{|c|c|} \hline 2 & 1 \\ \hline - & 4 \\ \hline \hline 2 & 7 \\ \hline \end{array}$$

i. 
$$\begin{array}{|c|c|} \hline 2 & 9 \\ \hline + & 8 \\ \hline \hline 3 & 7 \\ \hline \end{array}$$

j. 
$$\begin{array}{|c|c|} \hline 2 & 7 \\ \hline - & 9 \\ \hline \hline 2 & 8 \\ \hline \end{array}$$

Please use 10-sticks and loose beans

Favor de usar palos de 10 y frijoles sueltos

10-sticks	palos de 10	loose beans frijoles sueltos

10-sticks loose beans

$$\begin{array}{r}
 \begin{array}{|c|c|} \hline 3 & 2 \\ \hline 4 & 2 \\ \hline \hline 2 & 3 \\ \hline \end{array} \\
 (23) \\
 (23) - \\
 ( )
 \end{array}$$

$$\begin{array}{r}
 \begin{array}{|c|c|} \hline 4 & 1 \\ \hline 5 & 1 \\ \hline \hline 2 & 3 \\ \hline \end{array} \\
 - \\
 28 \\
 \hline
 23
 \end{array}$$

palos de 10 frijoles sueltos

$$\begin{array}{r}
 \begin{array}{|c|c|} \hline 3 & 0 \\ \hline 4 & 0 \\ \hline \hline 2 & 5 \\ \hline \end{array} \\
 - \\
 15 \\
 \hline
 25
 \end{array}$$

$$\begin{array}{r}
 \begin{array}{|c|c|} \hline 5 & 7 \\ \hline 6 & 7 \\ \hline \hline 3 & 8 \\ \hline \end{array} \\
 (38) \\
 ( ) - \\
 ( )
 \end{array}$$

$$\begin{array}{r}
 \begin{array}{|c|c|} \hline 4 & 0 \\ \hline 5 & 0 \\ \hline \hline 1 & 2 \\ \hline \end{array} \\
 - \\
 38 \\
 \hline
 12
 \end{array}$$

$$\begin{array}{r}
 \begin{array}{|c|c|} \hline 3 & 3 \\ \hline 4 & 3 \\ \hline \hline 2 & 6 \\ \hline \end{array} \\
 - \\
 17 \\
 \hline
 26
 \end{array}$$

Please use 10-sticks and loose beans making up your own examples.

Favor de usar palos de 10 y frijoles sueltos cuando haga sus propios ejemplos.

10-sticks

palos de 10

loose beans  
frijoles sueltos

10-sticks loose beans

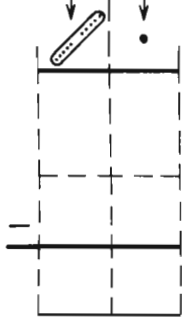

palos de 10 frijoles sueltos

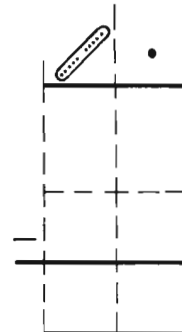
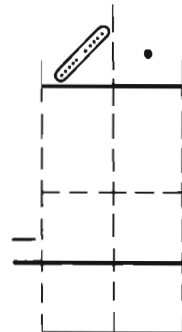
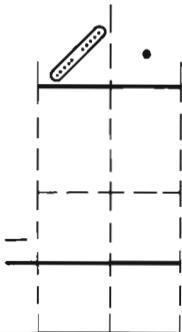
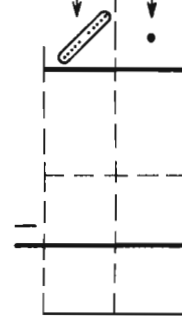
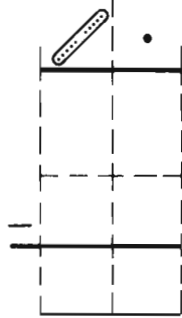

Trading: a 10-stick for 10 beans

Cambiando: un palo de 10 por 10 frijoles

10-sticks      loose beans

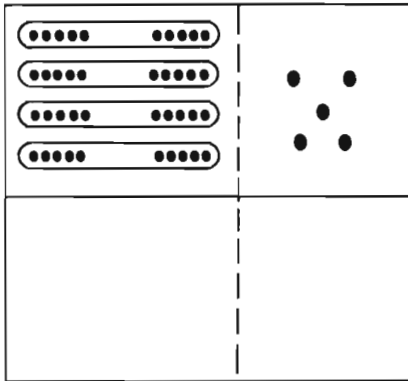

palos de 10      frijoles sueltos

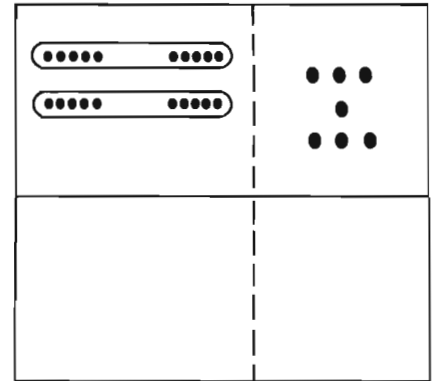
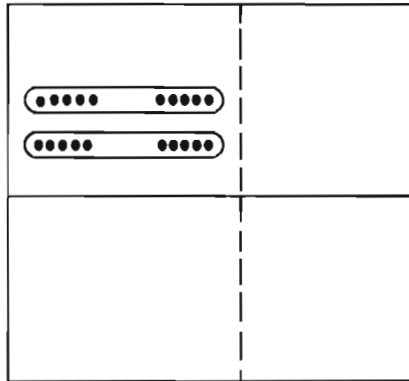

(27)

( )

( )

$$\begin{array}{r}
 \begin{array}{|c|c|} \hline \cdot & \\ \hline \text{10-stick} & \\ \hline 3 & 5 \\ \hline \text{4} & \\ \hline 1 & 8 \\ \hline 2 & 7 \\ \hline \end{array} \\
 - \\
 \hline
 \end{array}$$

$$\begin{array}{r}
 \begin{array}{|c|c|} \hline \cdot & \\ \hline \text{10-stick} & \\ \hline 2 & 10 \\ \hline 2 & 0 \\ \hline & 7 \\ \hline 1 & 3 \\ \hline \end{array} \\
 - \\
 \hline
 \end{array}$$

$$\begin{array}{r}
 \begin{array}{|c|c|} \hline \cdot & \\ \hline \text{10-stick} & \\ \hline 2 & 7 \\ \hline 2 & 0 \\ \hline 1 & 5 \\ \hline 1 & 2 \\ \hline \end{array} \\
 - \\
 \hline
 \end{array}$$

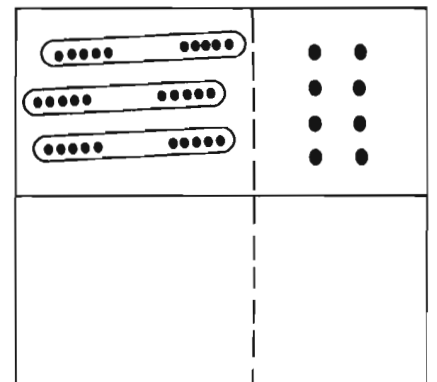
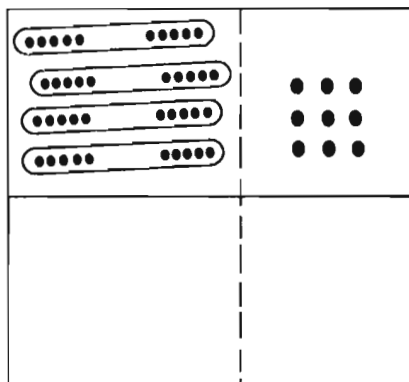
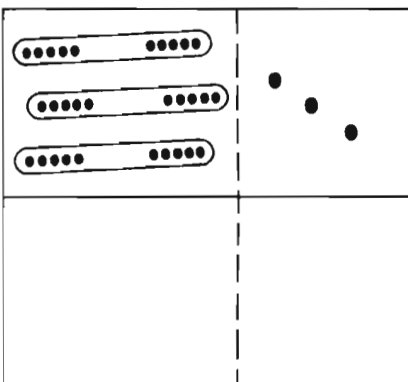

(17)

( )

( )

$$\begin{array}{r}
 \begin{array}{|c|c|} \hline \cdot & \\ \hline \text{10-stick} & \\ \hline 2 & 3 \\ \hline \text{3} & \\ \hline 1 & 6 \\ \hline 1 & 7 \\ \hline \end{array} \\
 - \\
 \hline
 \end{array}$$

$$\begin{array}{r}
 \begin{array}{|c|c|} \hline \cdot & \\ \hline \text{10-stick} & \\ \hline 4 & 9 \\ \hline 4 & 0 \\ \hline 2 & 7 \\ \hline 2 & 2 \\ \hline \end{array} \\
 - \\
 \hline
 \end{array}$$

$$\begin{array}{r}
 \begin{array}{|c|c|} \hline \cdot & \\ \hline \text{10-stick} & \\ \hline 2 & 8 \\ \hline \text{3} & \\ \hline 1 & 9 \\ \hline 1 & 9 \\ \hline \end{array} \\
 - \\
 \hline
 \end{array}$$

one way to make the arrangement

una manera de arreglar los dados

Please arrange each set of boxes to show examples of addition and subtraction.

Favor de arreglar cada grupo de dados para demostrar ejemplos de sumas y restas.

$$\begin{array}{r} 13 \\ + 84 \\ \hline 97 \end{array}$$

$$\begin{array}{r} 79 \\ - 41 \\ \hline 38 \end{array}$$

k.

k.

1	3	$\begin{array}{r} 13 \\ + 84 \\ \hline 97 \end{array}$	$\begin{array}{r} 79 \\ - 41 \\ \hline 38 \end{array}$	$\begin{array}{r} 38 \\ + 41 \\ \hline 79 \end{array}$
4	7			
8	9			

$$\begin{array}{r} 65 \\ + 24 \\ \hline 89 \end{array}$$

$$\begin{array}{r} 8 \\ - 4 \\ \hline 65 \end{array}$$

$$\begin{array}{r} 98 \\ - 46 \\ \hline 5 \end{array}$$

l.

l.

2	4	$\begin{array}{r} 65 \\ + 24 \\ \hline 89 \end{array}$	$\begin{array}{r} 89 \\ - 24 \\ \hline 65 \end{array}$	$\begin{array}{r} 98 \\ - 46 \\ \hline 5 \end{array}$
5	6			
8	9			

$$\begin{array}{r} 16 \\ + 2 \\ \hline 5 \end{array}$$

$$\begin{array}{r} 21 \\ + 64 \\ \hline 85 \end{array}$$

m.

m.

1	2	$\begin{array}{r} 16 \\ + 42 \\ \hline 58 \end{array}$	$\begin{array}{r} 21 \\ + 64 \\ \hline 85 \end{array}$	$\begin{array}{r} 58 \\ - 46 \\ \hline 12 \end{array}$
4	5			
6	8			

$$\begin{array}{r} 45 \\ + 37 \\ \hline 2 \end{array}$$

$$\begin{array}{r} 28 \\ + 45 \\ \hline 3 \end{array}$$

n.

n.

2	3	$\begin{array}{r} 45 \\ + 37 \\ \hline 82 \end{array}$	$\begin{array}{r} 28 \\ + 45 \\ \hline 73 \end{array}$	$\begin{array}{r} 73 \\ - 45 \\ \hline 28 \end{array}$
4	5			
7	8			

$$\begin{array}{r} 36 \\ + 45 \\ \hline 1 \end{array}$$

$$\begin{array}{r} 16 \\ + 38 \\ \hline 1 \end{array}$$

o.

o.

1	3	$\begin{array}{r} 36 \\ + 45 \\ \hline 81 \end{array}$	$\begin{array}{r} 16 \\ + 38 \\ \hline 54 \end{array}$	$\begin{array}{r} 83 \\ - 18 \\ \hline 45 \end{array}$
4	5			
6	8			

Trading: a 10-stick for 10 beans.

Cambiando: un palo de 10 por 10 frijoles

The child may cross out a beanstick and draw in 10 more beans; if he has difficulty doing this, continue using real beansticks and beans.

10-sticks      loose beans

palos de 10      frijoles sueltos

(18)     

	.
2	3
13	5
<hr/>	
	8

	.
2	3
1	0
<hr/>	
1	3

	.
<del>2</del>	<del>3</del>
1	5
<hr/>	
	8

	.
3	4
	1
<hr/>	
2	3

	.
<del>3</del>	<del>0</del>
1	8
<hr/>	
1	2

	.
<del>3</del>	<del>6</del>
1	7
<hr/>	
1	9



Trading: a 10-stick for 10 beans

Cambiando: un palo de 10 por 10 frijoles

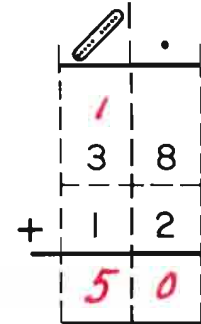
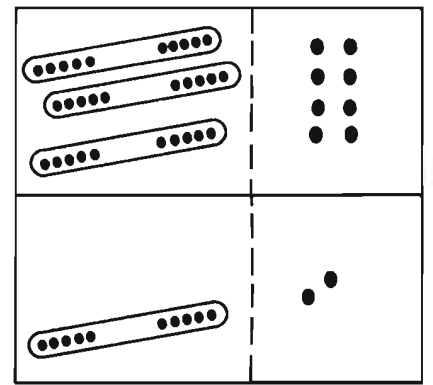
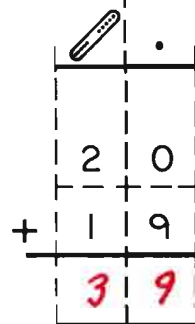
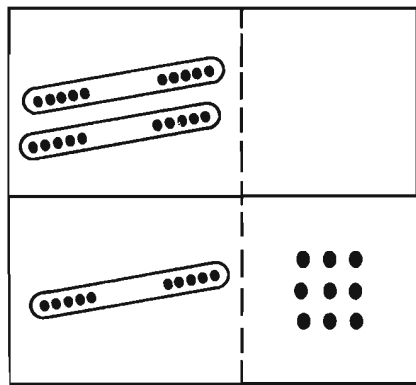
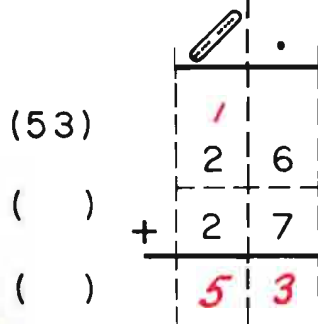
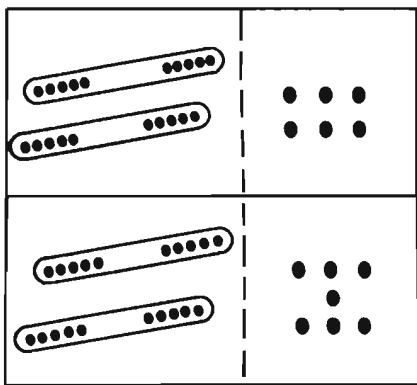
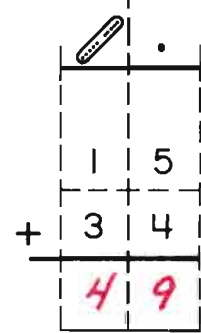
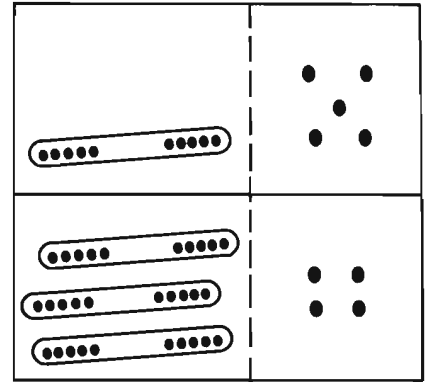
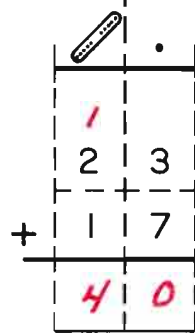
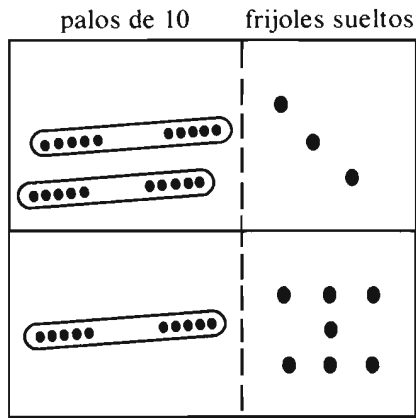
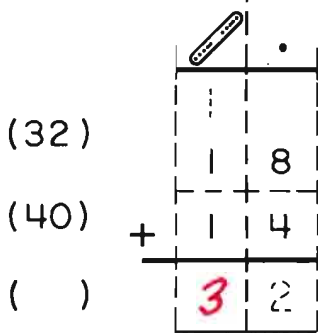
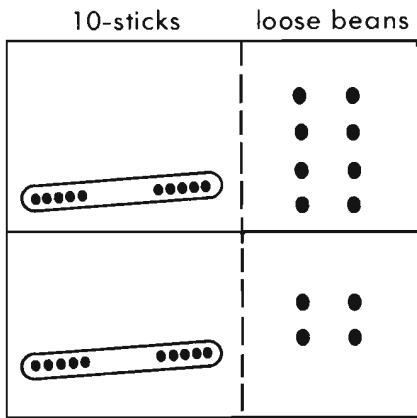

Please use 10-sticks and loose beans

Favor de usar palos de 10 y frijoles sueltos

10-sticks

palos de 10

loose beans  
frijoles sueltos

See also: D.I. pp. 63-71, D&P pp. 43-47

10-sticks

loose beans

$$\begin{array}{r}
 \text{10-sticks} \quad \downarrow \quad \downarrow \text{loose beans} \\
 \begin{array}{|c|c|} \hline \cdot \\ \hline 3 & 7 \\ \hline 1 & 5 \\ \hline 2 & 2 \\ \hline \end{array}
 \end{array}$$

palos de 10

frijoles sueltos

$$\begin{array}{r}
 \begin{array}{|c|c|} \hline \cdot \\ \hline 2 & 2 \\ \hline 1 & 9 \\ \hline 1 & 3 \\ \hline \end{array}
 \end{array}$$

$$\begin{array}{r}
 \begin{array}{|c|c|} \hline \cdot \\ \hline 3 & 7 \\ \hline 4 & 1 \\ \hline 2 & 7 \\ \hline 1 & 4 \\ \hline \end{array}
 \end{array}$$

(24)

( )

$$\begin{array}{r}
 \begin{array}{|c|c|} \hline \cdot \\ \hline 3 & 2 \\ \hline 4 & 8 \\ \hline 2 & 4 \\ \hline \end{array}
 \end{array}$$

-

$$\begin{array}{r}
 \begin{array}{|c|c|} \hline \cdot \\ \hline 5 & 6 \\ \hline 1 & 2 \\ \hline 4 & 4 \\ \hline \end{array}
 \end{array}$$

-

$$\begin{array}{r}
 \begin{array}{|c|c|} \hline \cdot \\ \hline 4 & 0 \\ \hline 5 & 6 \\ \hline 2 & 6 \\ \hline 2 & 4 \\ \hline \end{array}
 \end{array}$$

Trading: a 10-stick for 10 beans

Cambiando: un palo de 10 por 10 frijoles

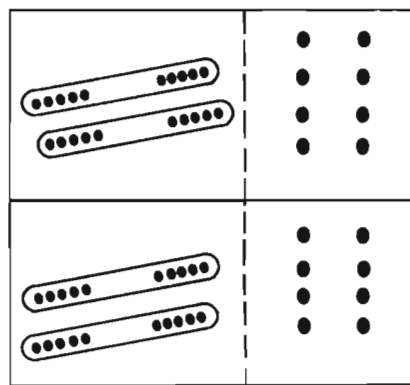
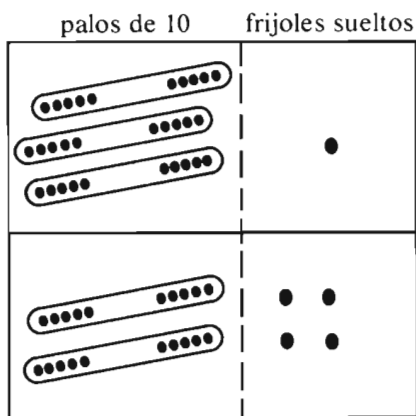
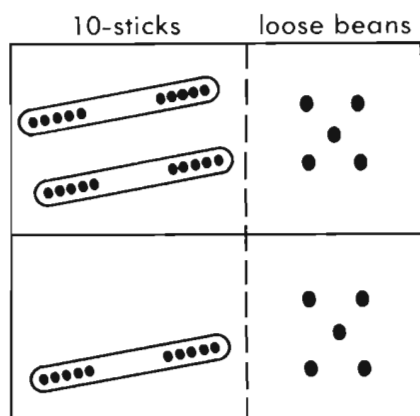

$$\begin{array}{r}
 ( ) \\
 ( ) \\
 (56)
 \end{array}
 \begin{array}{r}
 \begin{array}{|c|c|}
 \hline
 & \cdot \\
 \hline
 1 & \\
 \hline
 2 & 5 \\
 \hline
 + & 1 & 5 \\
 \hline
 4 & 0 \\
 \hline
 \end{array}
 \end{array}$$

$$\begin{array}{r}
 ( ) \\
 ( ) \\
 (55)
 \end{array}
 \begin{array}{r}
 \begin{array}{|c|c|}
 \hline
 & \cdot \\
 \hline
 3 & 1 \\
 \hline
 + & 2 & 4 \\
 \hline
 5 & 5 \\
 \hline
 \end{array}
 \end{array}$$

$$\begin{array}{r}
 ( ) \\
 ( ) \\
 (56)
 \end{array}
 \begin{array}{r}
 \begin{array}{|c|c|}
 \hline
 & \cdot \\
 \hline
 1 & \\
 \hline
 2 & 8 \\
 \hline
 + & 2 & 8 \\
 \hline
 5 & 6 \\
 \hline
 \end{array}
 \end{array}$$

See also: D.I. pp. 63-71, D&P pp. 43-47

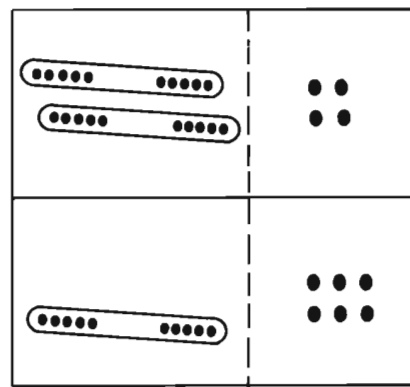
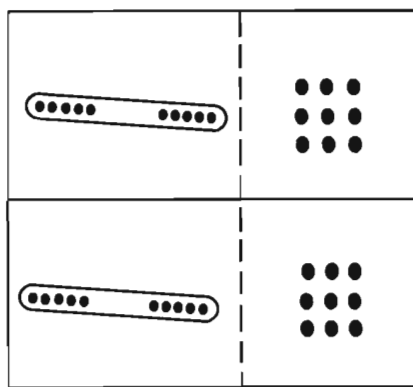
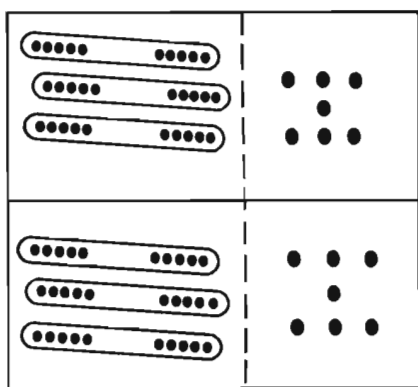

$$\begin{array}{r}
 (74) \\
 ( ) \\
 ( )
 \end{array}
 \begin{array}{r}
 \begin{array}{|c|c|}
 \hline
 & \cdot \\
 \hline
 1 & \\
 \hline
 3 & 7 \\
 \hline
 + & 3 & 7 \\
 \hline
 7 & 4 \\
 \hline
 \end{array}
 \end{array}$$

$$\begin{array}{r}
 ( ) \\
 ( ) \\
 (38)
 \end{array}
 \begin{array}{r}
 \begin{array}{|c|c|}
 \hline
 & \cdot \\
 \hline
 1 & \\
 \hline
 1 & 9 \\
 \hline
 + & 1 & 9 \\
 \hline
 3 & 8 \\
 \hline
 \end{array}
 \end{array}$$

$$\begin{array}{r}
 ( ) \\
 ( ) \\
 (40)
 \end{array}
 \begin{array}{r}
 \begin{array}{|c|c|}
 \hline
 & \cdot \\
 \hline
 1 & \\
 \hline
 2 & 4 \\
 \hline
 + & 1 & 6 \\
 \hline
 4 & 0 \\
 \hline
 \end{array}
 \end{array}$$

On Your Own

Usted Solo

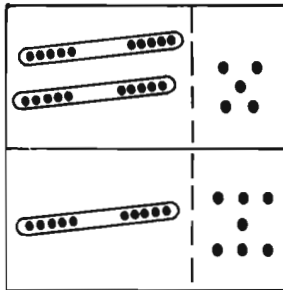

$$\begin{array}{r} \overset{1}{\phantom{0}} \\ 25 \\ + 17 \\ \hline 42 \end{array}$$

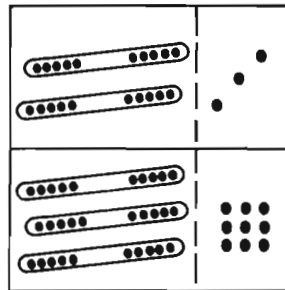

$$\begin{array}{r} \overset{1}{\phantom{0}} \\ 39 \\ + 23 \\ \hline 62 \end{array}$$

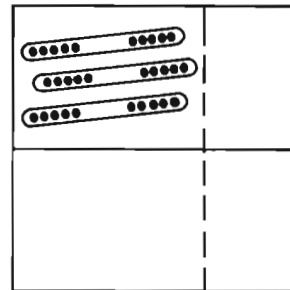

$$\begin{array}{r} \overset{2}{\phantom{0}} \\ 30 \\ - 12 \\ \hline 18 \end{array}$$

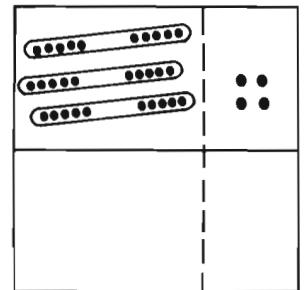

$$\begin{array}{r} \overset{3}{\phantom{0}} \\ 34 \\ - 18 \\ \hline 16 \end{array}$$

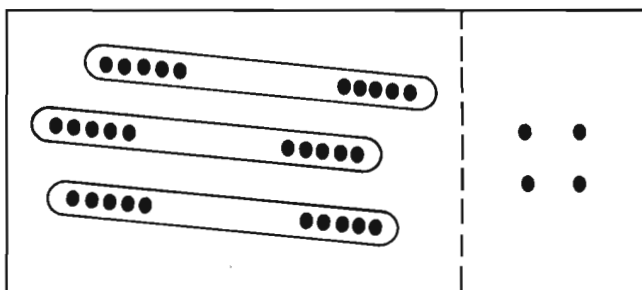

$$\begin{array}{r} \overset{1}{\phantom{0}} \\ 34 \\ + 16 \\ \hline 50 \end{array}$$

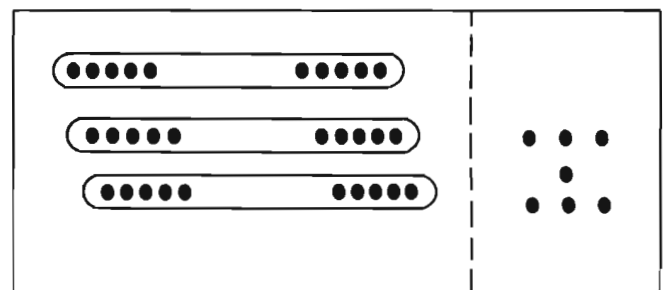

$$\begin{array}{r} \overset{1}{\phantom{0}} \\ 34 \\ + 28 \\ \hline 62 \end{array}$$

$$\begin{array}{r} \overset{1}{\phantom{0}} \\ 37 \\ + 15 \\ \hline 52 \end{array}$$

$$\begin{array}{r} \overset{1}{\phantom{0}} \\ 37 \\ + 53 \\ \hline 90 \end{array}$$

$$\begin{array}{r} \overset{2}{\phantom{0}} \\ 34 \\ - 19 \\ \hline 15 \end{array}$$

$$\begin{array}{r} \overset{2}{\phantom{0}} \\ 34 \\ - 25 \\ \hline 9 \end{array}$$

$$\begin{array}{r} \overset{2}{\phantom{0}} \\ 37 \\ - 28 \\ \hline 9 \end{array}$$

How do you feel?  
¿Cómo se siente?



Dear Parents,

With this progress test you can see that your child can now compute problems where regrouping (discussed in the previous letter) is involved, not only in addition problems but also in subtraction. After first manipulating the operations with tensticks and beans, the move was made to the use of representations on the pages in the book. These pictures remain important referents - constant reminders that the numbers and signs are symbols of concrete things in the "real" world. We only bypass understanding and self-confidence in the learner if we don't allow for sufficient time at these manipulative and representational levels.

Since "sufficient" time varies with each individual learner, we encourage you to use sticks and beans (or pictures if your child is comfortable at that level) for as long as you feel the need when practicing at home. Once frustration and failure begin, chances for learning diminish quickly. So it's important to work at the level at which your child feels comfortable, moving on when he or she gives a clear sign of readiness.

For many children, regrouping in subtraction is more difficult than in addition. Your child has successfully done lots of it now, so you can ask what "happens" in this operation and go over it with tensticks and beans. If you need to help, here's how:

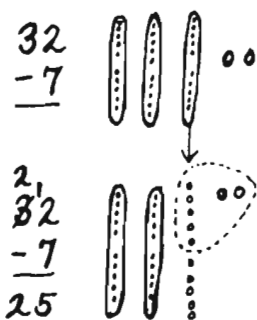

Working with the ones (loose beans) first, you haven't enough to take 7 away. So you'll need to trade one tenstick for 10 loose beans. Mark in the tens column that you now have one less ten and in the ones column mark that you have ten more ones. Now complete the subtraction - first with the ones, then the tens.

Thank you again for all your support and encouragement!

Sincerely,

A.

$4 + 5 = 9$

B.

$6 + 5 = 11$

C.

$3 + 8 = 11$

D.

$6 + 8 = 14$

E.

$3 + 10 = 13$

F.

$9 + 5 = 14$

G.

$8 + 5 = 13$

H.

$4 + 10 = 14$

A.

$4 + 5 = 9$

C.

$3 + 8 = 11$

E.

$3 + 10 = 13$

G.

$8 + 5 = 13$

B.

$6 + 5 = 11$

D.

$6 + 8 = 14$

F.

$9 + 5 = 14$

H.

$4 + 10 = 14$



How many crossing points?

¿Cuántos cruces?

Children who desire should feel free to use toothpicks with the diagrams on this and any similar pages.

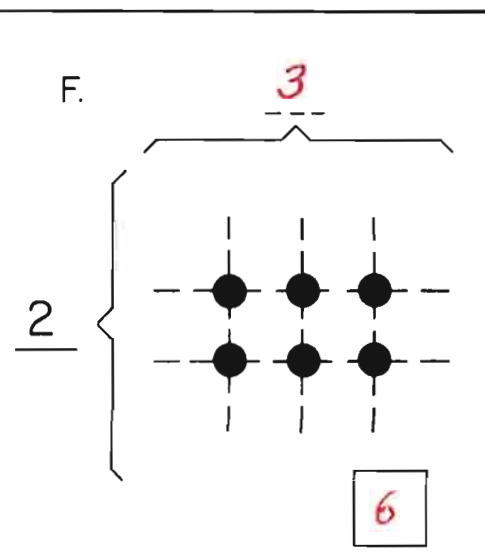
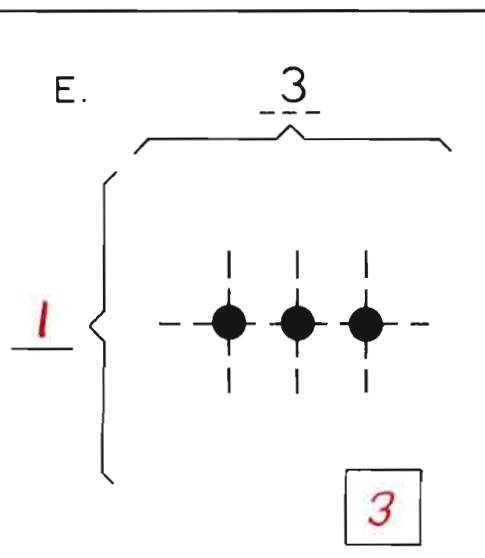
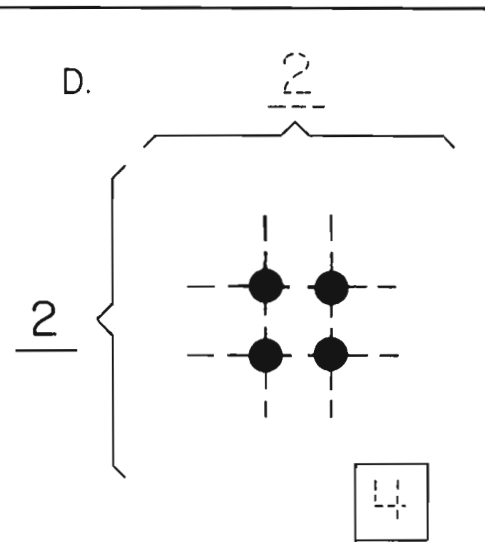
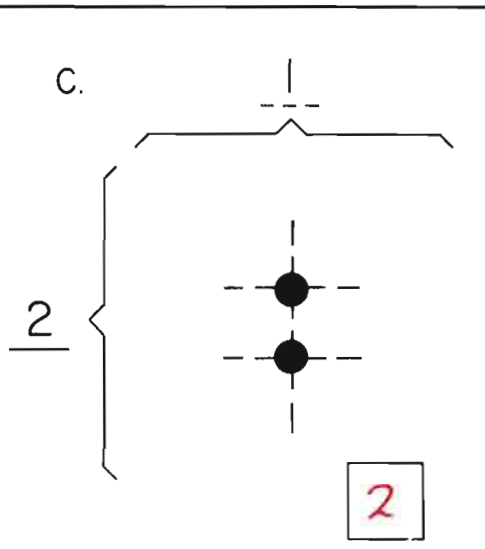
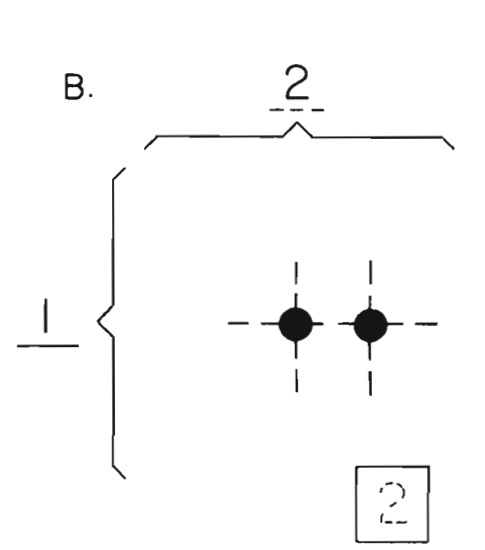
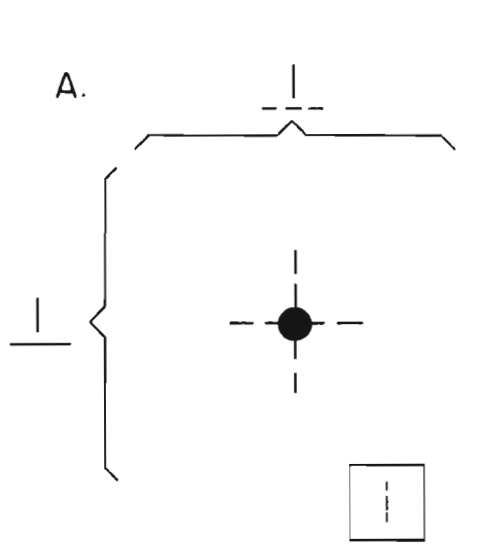
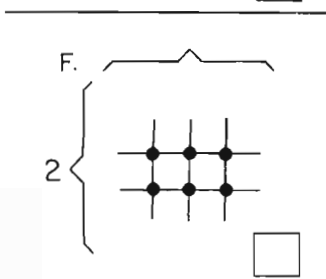
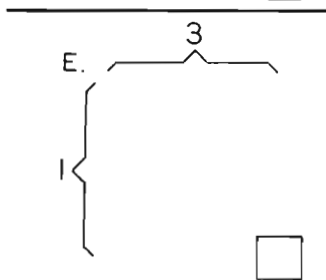
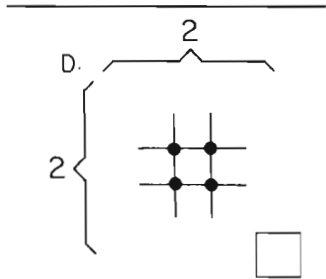
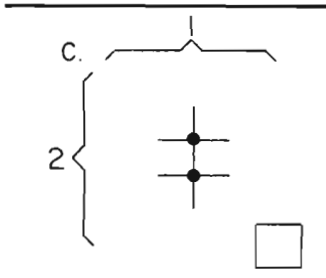
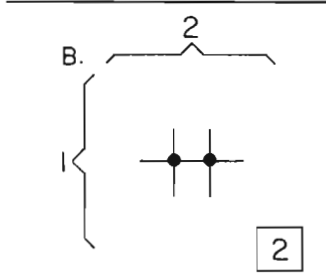
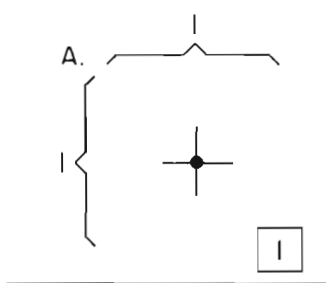

Please draw your own lines and crossing points.

Favor de hacer sus propias líneas y cruces.

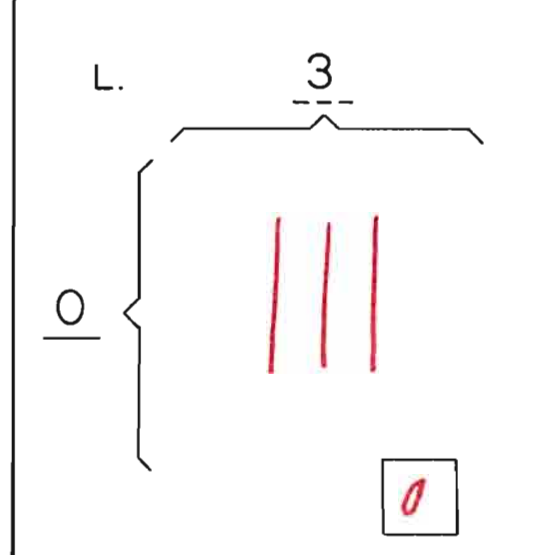
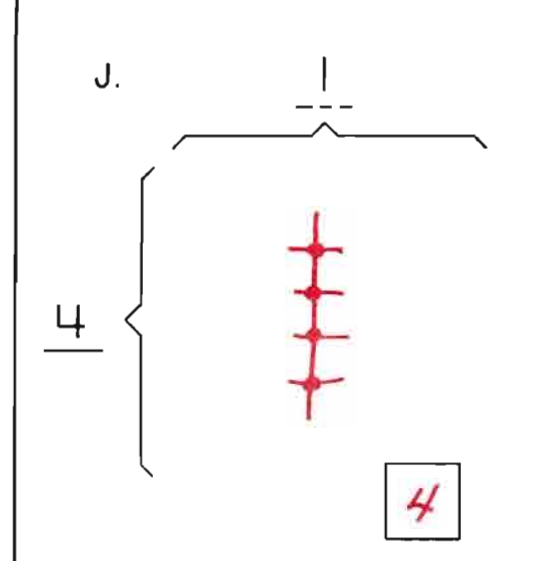
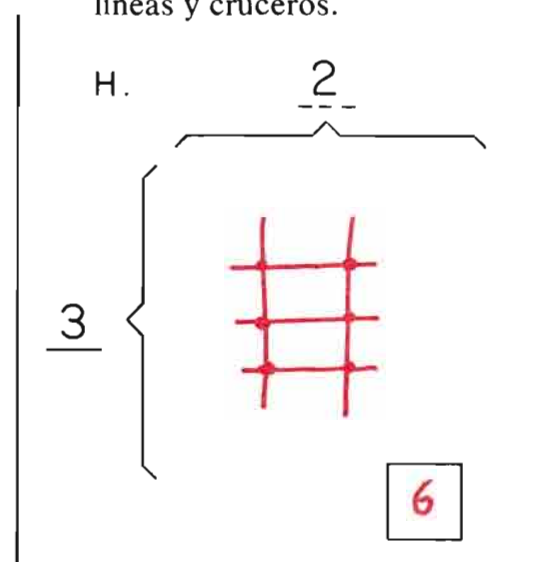
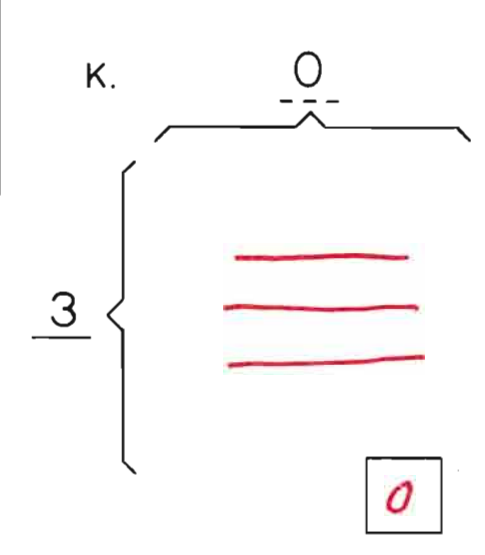
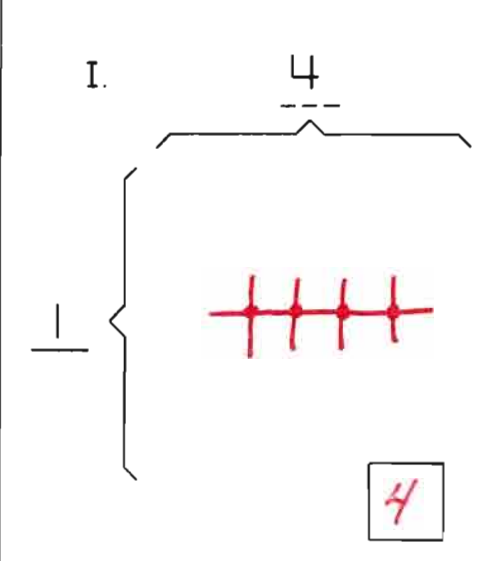
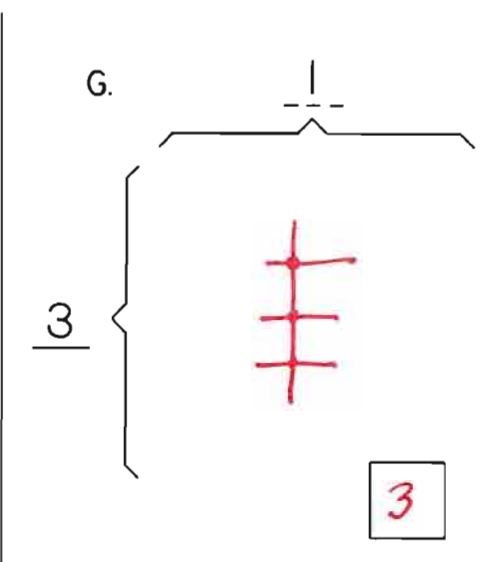
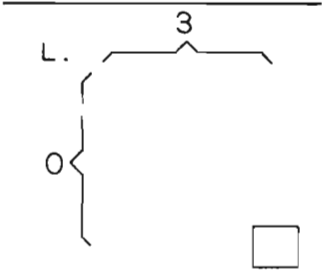
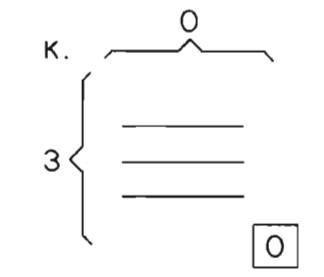
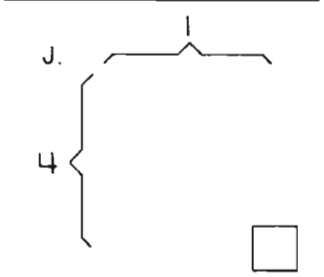
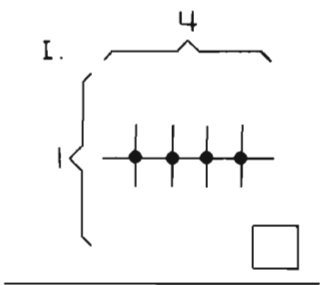
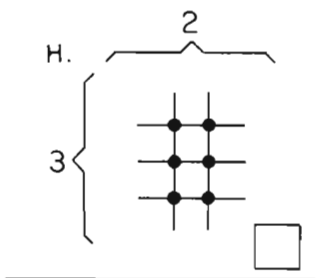
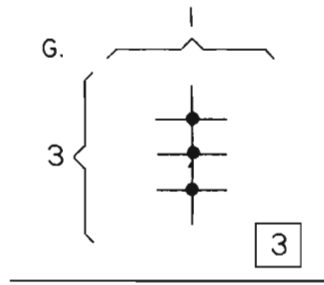

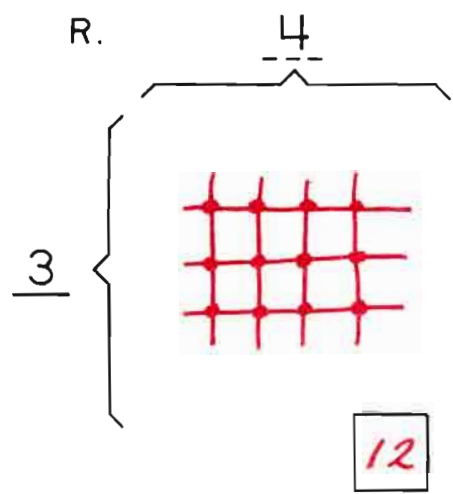
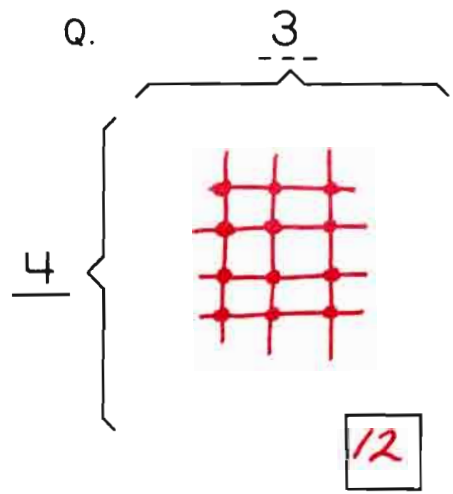
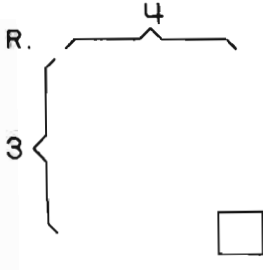
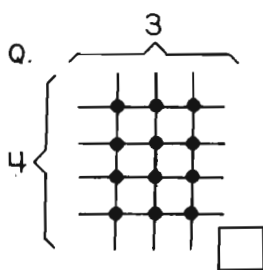
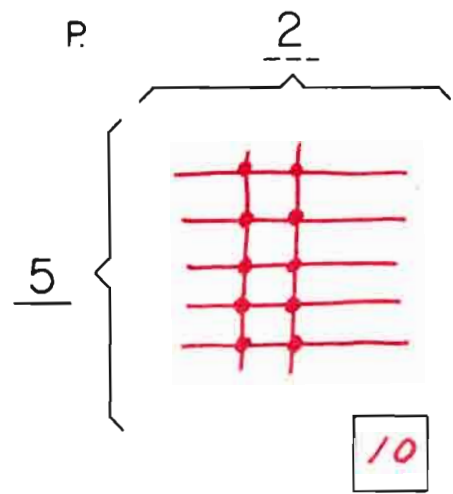
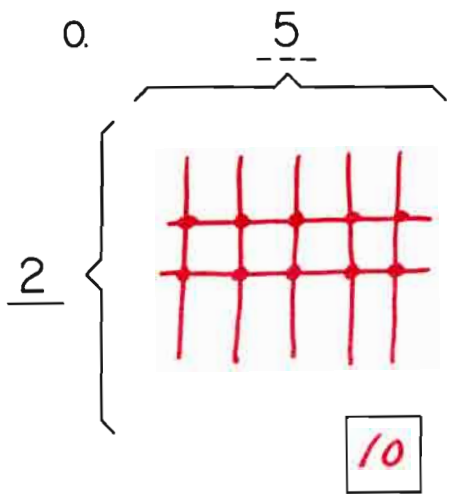
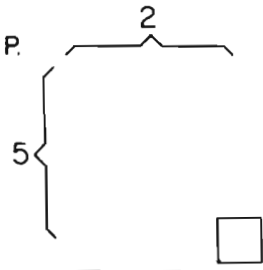
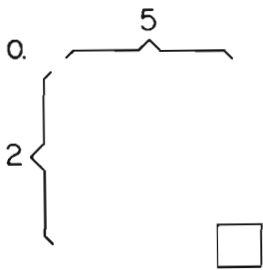
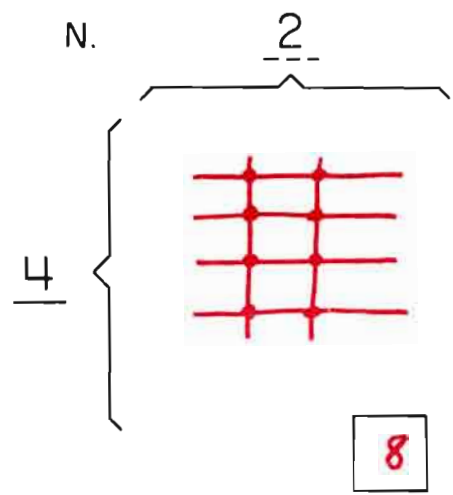
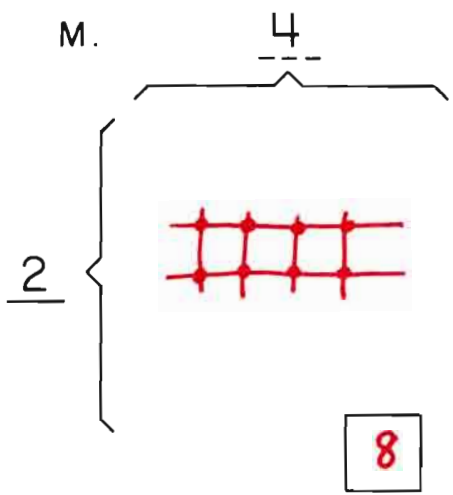
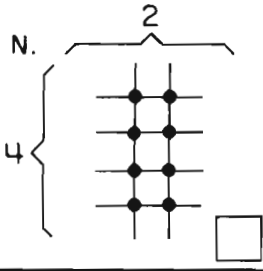
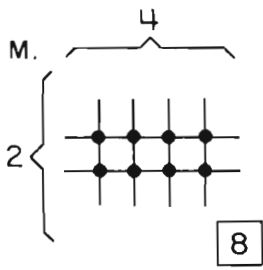

See also: D.I. pp. 49-57

- A. 10  
   1 10's
- B. 20  
   2 10's
- C. \_\_\_\_\_  
   \_\_\_\_\_ 10's
- D. 30  
   \_\_\_\_\_ 10's
- E. 50  
   \_\_\_\_\_ 10's

A.	B.	C.	D.	E.
<u>10</u>	<u>20</u>	<u>40</u>	<u>30</u>	<u>50</u>
1 10	2 10's	4 10's	3 10's	5 10's

- F. \_\_\_\_\_  
   6 10's
- G. 80  
   \_\_\_\_\_ 10's
- H. \_\_\_\_\_  
   7 10's

F.	G.	H.
<u>60</u>	<u>80</u>	<u>70</u>
6 10's	8 10's	7 10's

- I. \_\_\_\_\_  
   \_\_\_\_\_ 10's
- J. 100  
   \_\_\_\_\_ 10's

I.	J.
<u>90</u>	<u>100</u>
9 10's	10 10's

d. It would be a good idea to make some hundreds rafts to use with tensticks and loose beans to manipulate <sup>a.</sup>

this idea of place value before the rest of these pages are done.

100  
 100's  
30  
 3 10's  
4  
 4 1's  
134  
 Total

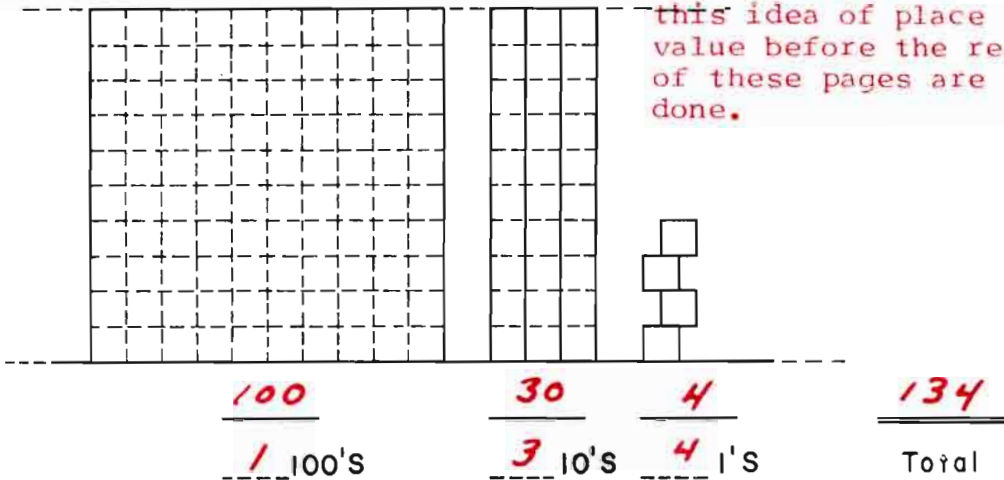

b.

b.

100  
 100's  
20  
 2 10's  
0  
 0 1's  
120  
 Total

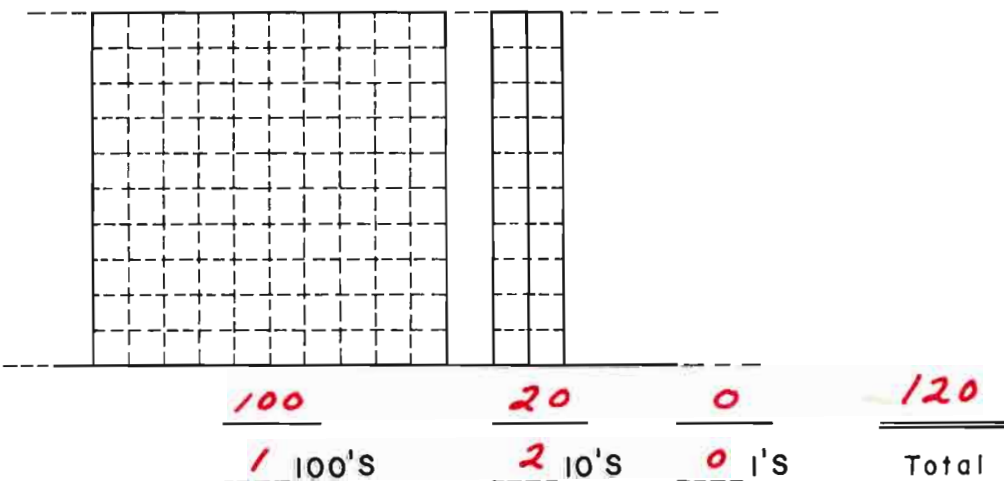

c.

c.

100  
 100's  
0  
 0 10's  
7  
 7 1's  
107  
 Total

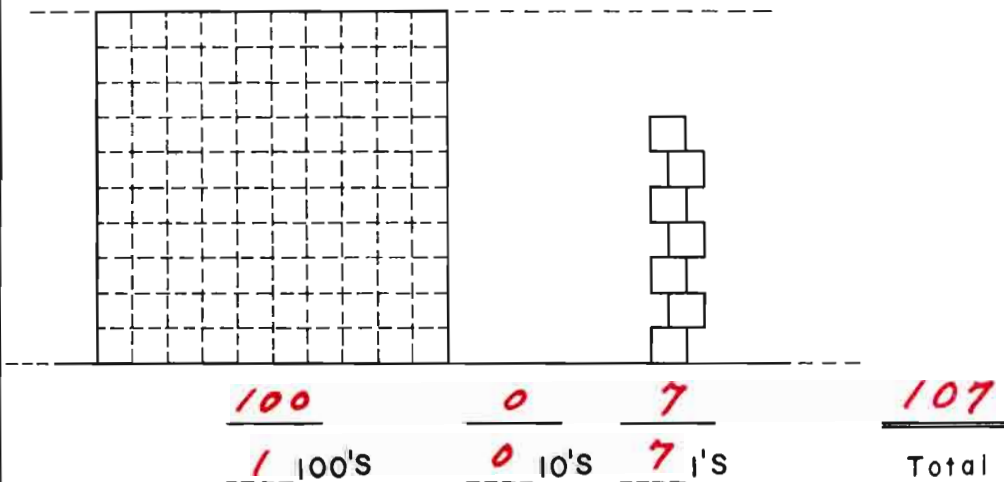

Please draw your own lines and crossing points.

Favor de hacer sus propias líneas y cruces.

S.  $\overbrace{\quad\quad\quad}^3$   
 $\left\{ \begin{array}{l} \text{---} \\ \bullet \quad \bullet \quad \bullet \\ \text{---} \\ \bullet \quad \bullet \quad \bullet \\ \text{---} \\ \bullet \quad \bullet \quad \bullet \end{array} \right.$   $\left. \begin{array}{l} 3 \\ 3 \\ 3 \end{array} \right\}$

S.  $\overbrace{\quad\quad\quad}^3$   
 $\left\{ \begin{array}{l} \text{---} \\ \text{---} \\ \text{---} \end{array} \right.$   $\left. \begin{array}{l} 3 \\ 3 \\ 3 \end{array} \right\}$   **9**

T.  $\overbrace{\quad\quad\quad}^4$   
 $\left\{ \begin{array}{l} \text{---} \\ \text{---} \\ \text{---} \\ \text{---} \end{array} \right.$   $\left. \begin{array}{l} 4 \\ 4 \\ 4 \\ 4 \end{array} \right\}$   **16**

T.  $\overbrace{\quad\quad\quad}^4$   
 $\left\{ \begin{array}{l} \bullet \quad \bullet \quad \bullet \quad \bullet \\ \bullet \quad \bullet \quad \bullet \quad \bullet \\ \bullet \quad \bullet \quad \bullet \quad \bullet \\ \bullet \quad \bullet \quad \bullet \quad \bullet \end{array} \right.$   $\left. \begin{array}{l} 4 \\ 4 \\ 4 \\ 4 \end{array} \right\}$

U.  $\overbrace{\quad\quad\quad}^5$   
 $\left\{ \begin{array}{l} \text{---} \\ \text{---} \\ \text{---} \end{array} \right.$   $\left. \begin{array}{l} 3 \\ 3 \\ 3 \end{array} \right\}$   **15**

U.  $\overbrace{\quad\quad\quad}^5$   
 $\left\{ \begin{array}{l} \text{---} \\ \text{---} \\ \text{---} \end{array} \right.$   $\left. \begin{array}{l} 3 \\ 3 \\ 3 \end{array} \right\}$   **15**

V.  $\overbrace{\quad\quad\quad}^3$   
 $\left\{ \begin{array}{l} \text{---} \\ \text{---} \\ \text{---} \\ \text{---} \\ \text{---} \end{array} \right.$   $\left. \begin{array}{l} 5 \\ 5 \\ 5 \\ 5 \\ 5 \end{array} \right\}$   **15**

V.  $\overbrace{\quad\quad\quad}^3$   
 $\left\{ \begin{array}{l} \bullet \quad \bullet \quad \bullet \quad \bullet \\ \bullet \quad \bullet \quad \bullet \quad \bullet \\ \bullet \quad \bullet \quad \bullet \quad \bullet \end{array} \right.$   $\left. \begin{array}{l} 5 \\ 5 \\ 5 \end{array} \right\}$

W.  $\overbrace{\quad\quad\quad}^0$   
 $\left\{ \begin{array}{l} \text{---} \\ \text{---} \\ \text{---} \\ \text{---} \end{array} \right.$   $\left. \begin{array}{l} 4 \\ 4 \\ 4 \\ 4 \end{array} \right\}$   **0**

W.  $\overbrace{\quad\quad\quad}^0$   
 $\left\{ \begin{array}{l} \text{---} \\ \text{---} \\ \text{---} \\ \text{---} \end{array} \right.$   $\left. \begin{array}{l} 4 \\ 4 \\ 4 \\ 4 \end{array} \right\}$   **0**

X.  $\overbrace{\quad\quad\quad}^5$   
 $\left\{ \begin{array}{l} \bullet \quad \bullet \quad \bullet \quad \bullet \quad \bullet \end{array} \right.$   $\left. \begin{array}{l} 1 \\ 1 \\ 1 \\ 1 \\ 1 \end{array} \right\}$   **5**

X.  $\overbrace{\quad\quad\quad}^5$   
 $\left\{ \begin{array}{l} \text{---} \\ \text{---} \\ \text{---} \\ \text{---} \\ \text{---} \end{array} \right.$   $\left. \begin{array}{l} 1 \\ 1 \\ 1 \\ 1 \\ 1 \end{array} \right\}$



This page is the child's introduction to division at the representational level, but needn't be explained as a division process. Child draws in

the missing horizontal and/or vertical lines necessary to get the number of crossing points named in the square.

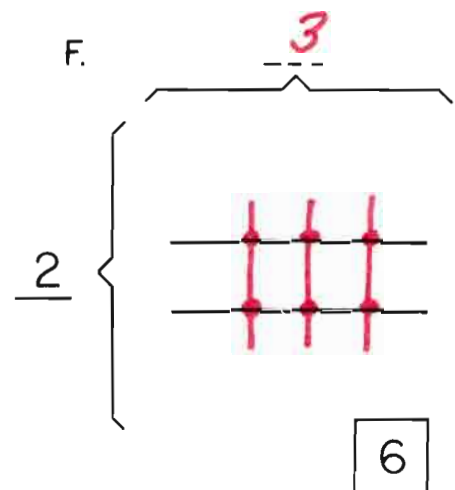
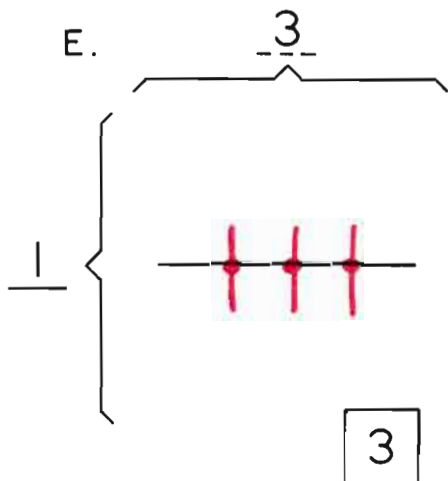
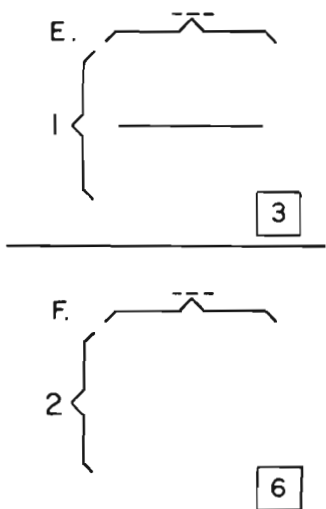
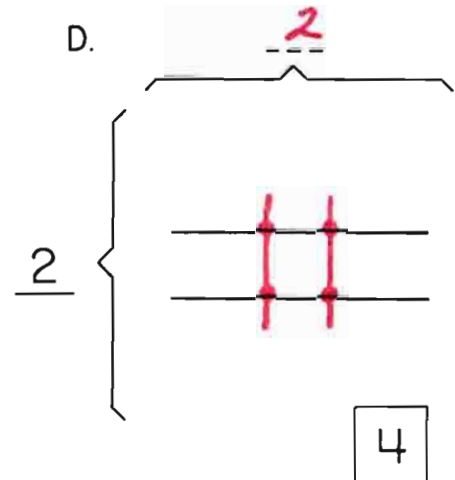
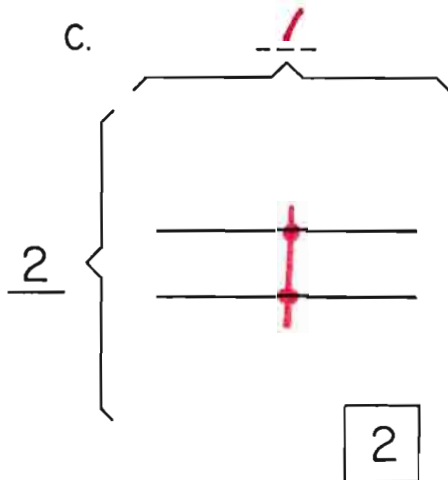
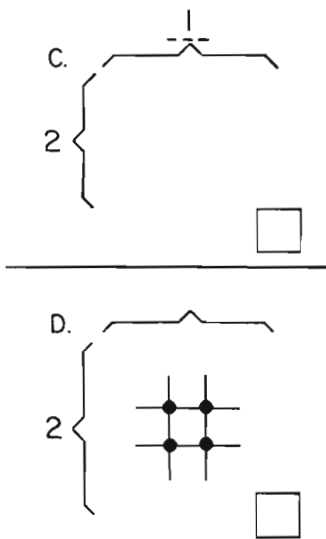
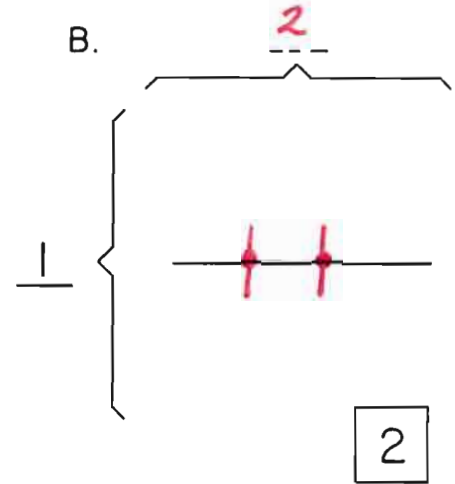
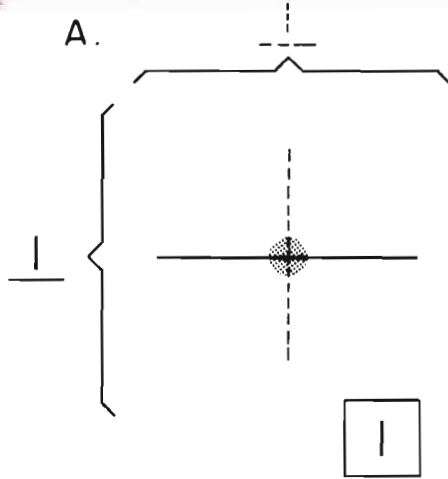
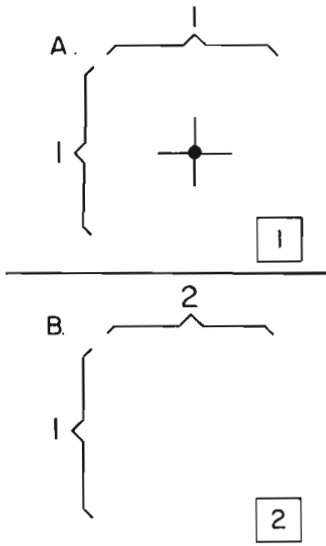

d. 1 4 6

d. **1 4 6**  
100's    10's    1's

See also: D.I. pp. 49-59

e. 2 1 3

e. **2 1 3**  
100's    10's    1's

f.     

f. **2 5 8**

g.     

g. **1 6 2**

h. 2 3 5

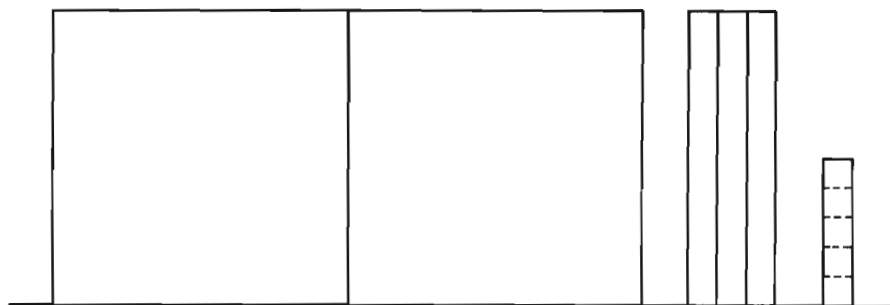

h. 2 3 5

i.     

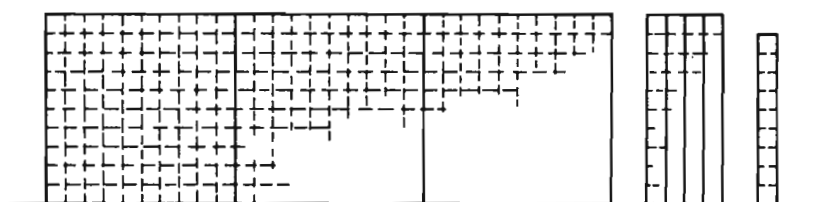

i. 3 4 9

j. 2 3 4

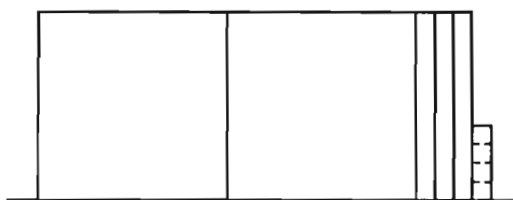

j. 2 3 4

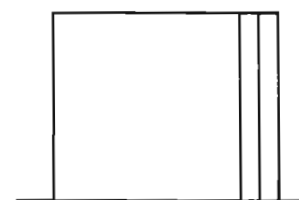

k. 1 2 0

k.     

l.     

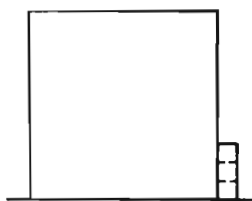

l. 1 0 3

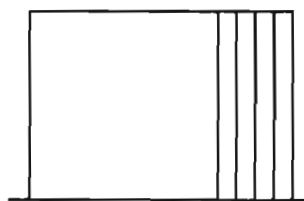

m. 1 4 0

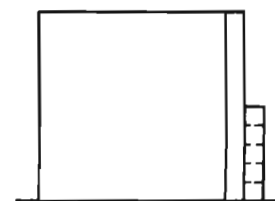

n. 1 1 5

m. 1 4 0

n.     

o. 4 7 8

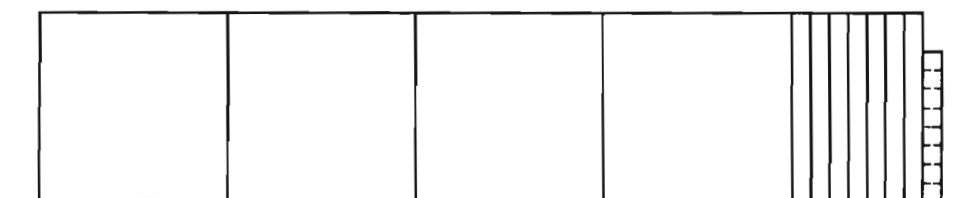

o. 4 7 8

Many children may need to use the hundreds rafts, tensticks and beans to manipulate some of these operations until they feel confident enough to work with the pictures on the page.

$$\begin{array}{r} 175 \\ + 1 \\ \hline 176 \end{array} \quad \begin{array}{r} 175 \\ + 10 \\ \hline \end{array} \quad \begin{array}{r} 175 \\ + 100 \\ \hline 275 \end{array}$$

$$\begin{array}{r} 175 \\ + 5 \\ \hline \end{array}$$

$$\begin{array}{r} 175 \\ - 1 \\ \hline 174 \end{array} \quad \begin{array}{r} 175 \\ - 10 \\ \hline 165 \end{array} \quad \begin{array}{r} 175 \\ - 100 \\ \hline \end{array}$$

$$\begin{array}{r} 175 \\ - 5 \\ \hline \end{array}$$

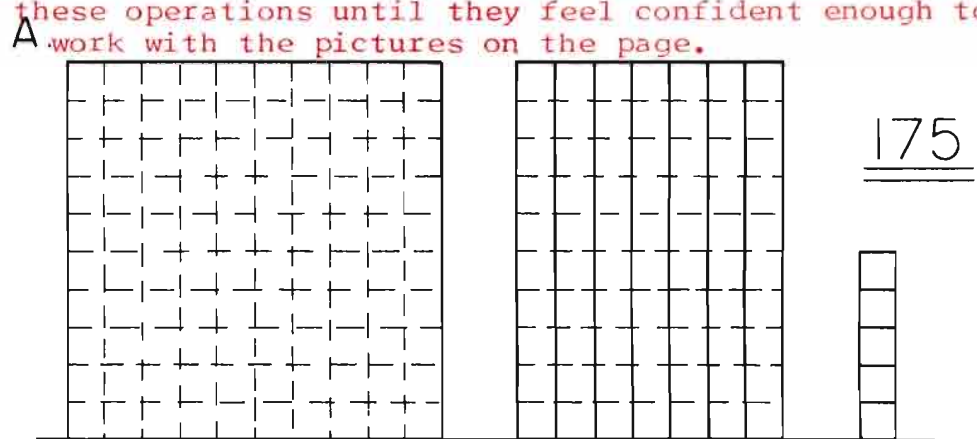

$$\begin{array}{r} 175 \\ + 1 \\ \hline 176 \end{array} \quad \begin{array}{r} 175 \\ + 10 \\ \hline 185 \end{array} \quad \begin{array}{r} 175 \\ + 100 \\ \hline 275 \end{array} \quad \begin{array}{r} 175 \\ + 5 \\ \hline 180 \end{array}$$

$$\begin{array}{r} 175 \\ - 1 \\ \hline 174 \end{array} \quad \begin{array}{r} 175 \\ - 10 \\ \hline 165 \end{array} \quad \begin{array}{r} 175 \\ - 100 \\ \hline 75 \end{array} \quad \begin{array}{r} 175 \\ - 5 \\ \hline 170 \end{array}$$

B.

$$\begin{array}{r} 134 \\ + 13 \\ \hline 147 \end{array} \quad \begin{array}{r} 134 \\ + 6 \\ \hline \end{array} \quad \begin{array}{r} 134 \\ + 16 \\ \hline 150 \end{array}$$

$$\begin{array}{r} 134 \\ + 103 \\ \hline \end{array}$$

$$\begin{array}{r} 134 \\ - 30 \\ \hline \end{array} \quad \begin{array}{r} 134 \\ - 104 \\ \hline \end{array} \quad \begin{array}{r} 134 \\ - 5 \\ \hline 129 \end{array}$$

$$\begin{array}{r} 134 \\ - 15 \\ \hline \end{array}$$

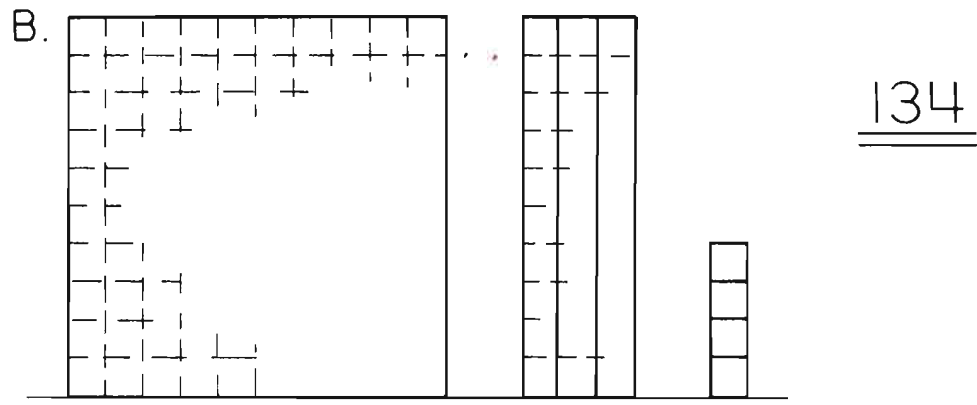

$$\begin{array}{r} 134 \\ + 13 \\ \hline 147 \end{array} \quad \begin{array}{r} 134 \\ + 6 \\ \hline 140 \end{array} \quad \begin{array}{r} 134 \\ + 16 \\ \hline 150 \end{array} \quad \begin{array}{r} 134 \\ + 103 \\ \hline 237 \end{array}$$

$$\begin{array}{r} 134 \\ - 30 \\ \hline 104 \end{array} \quad \begin{array}{r} 134 \\ - 104 \\ \hline 30 \end{array} \quad \begin{array}{r} 134 \\ - 5 \\ \hline 129 \end{array} \quad \begin{array}{r} 134 \\ - 15 \\ \hline 119 \end{array}$$

See also: D.I. pp. 76-77. 101-105

C.

$$\begin{array}{r} 128 \\ + 2 \\ \hline 130 \end{array} \quad \begin{array}{r} 128 \\ + 12 \\ \hline 140 \end{array} \quad \begin{array}{r} 128 \\ + 52 \\ \hline 180 \end{array}$$

$$\begin{array}{r} 128 \\ + 5 \\ \hline \end{array}$$

$$\begin{array}{r} 128 \\ - 27 \\ \hline 101 \end{array} \quad \begin{array}{r} 128 \\ - 10 \\ \hline \end{array} \quad \begin{array}{r} 128 \\ - 9 \\ \hline \end{array}$$

$$\begin{array}{r} 128 \\ - 19 \\ \hline 109 \end{array}$$

C.

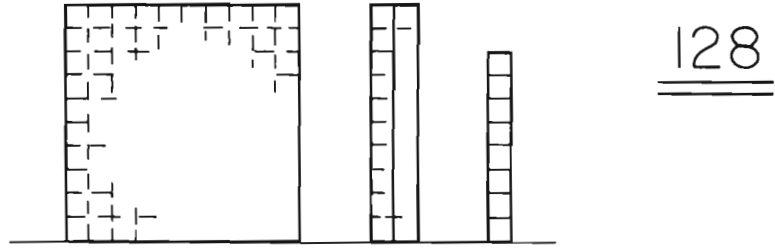

$$\begin{array}{r} 128 \\ + 2 \\ \hline 130 \end{array} \quad \begin{array}{r} 128 \\ + 12 \\ \hline 140 \end{array} \quad \begin{array}{r} 128 \\ + 52 \\ \hline 180 \end{array} \quad \begin{array}{r} 128 \\ + 5 \\ \hline 133 \end{array}$$

$$\begin{array}{r} 128 \\ - 27 \\ \hline 101 \end{array} \quad \begin{array}{r} 128 \\ - 10 \\ \hline 118 \end{array} \quad \begin{array}{r} 128 \\ - 9 \\ \hline 119 \end{array} \quad \begin{array}{r} 128 \\ - 19 \\ \hline 109 \end{array}$$

D.

$$\begin{array}{r} 236 \\ + 13 \\ \hline 249 \end{array} \quad \begin{array}{r} 236 \\ + 14 \\ \hline 250 \end{array} \quad \begin{array}{r} 236 \\ + 54 \\ \hline 290 \end{array}$$

$$\begin{array}{r} 236 \\ + 62 \\ \hline \end{array}$$

$$\begin{array}{r} 236 \\ - 30 \\ \hline 206 \end{array} \quad \begin{array}{r} 236 \\ - 29 \\ \hline 207 \end{array} \quad \begin{array}{r} 236 \\ - 200 \\ \hline 36 \end{array}$$

$$\begin{array}{r} 236 \\ - 209 \\ \hline 27 \end{array}$$

D.

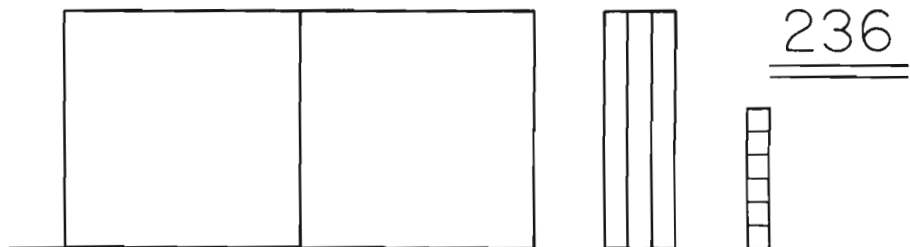

$$\begin{array}{r} 236 \\ + 13 \\ \hline 249 \end{array} \quad \begin{array}{r} 236 \\ + 14 \\ \hline 250 \end{array} \quad \begin{array}{r} 236 \\ + 54 \\ \hline 290 \end{array} \quad \begin{array}{r} 236 \\ + 62 \\ \hline 298 \end{array}$$

$$\begin{array}{r} 236 \\ - 30 \\ \hline 206 \end{array} \quad \begin{array}{r} 236 \\ - 29 \\ \hline 207 \end{array} \quad \begin{array}{r} 236 \\ - 200 \\ \hline 36 \end{array} \quad \begin{array}{r} 236 \\ - 209 \\ \hline 27 \end{array}$$

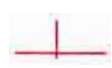

Please draw your own lines and crossing points.

Favor de hacer sus propias líneas y crucesos.

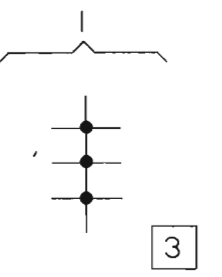
G. 

---

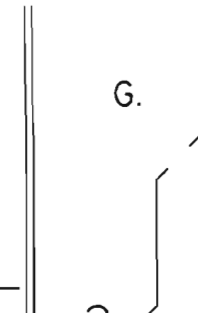
H. 

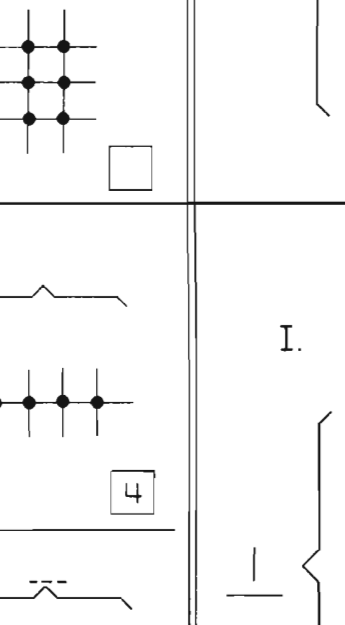
G. 

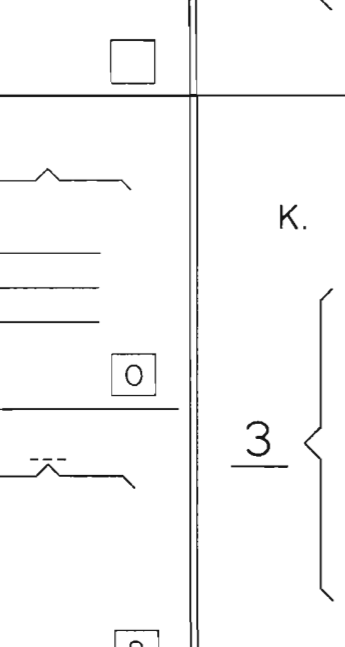
H. 

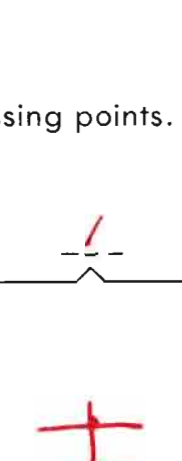
I. 

---

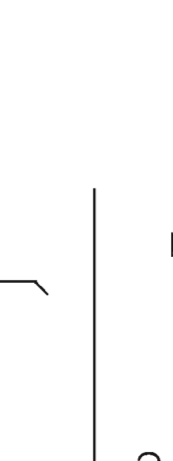
J. 

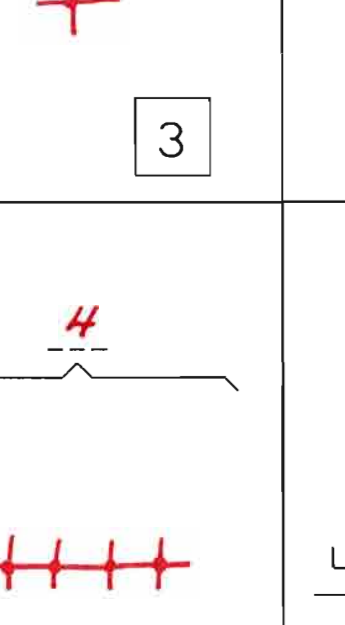
I. 

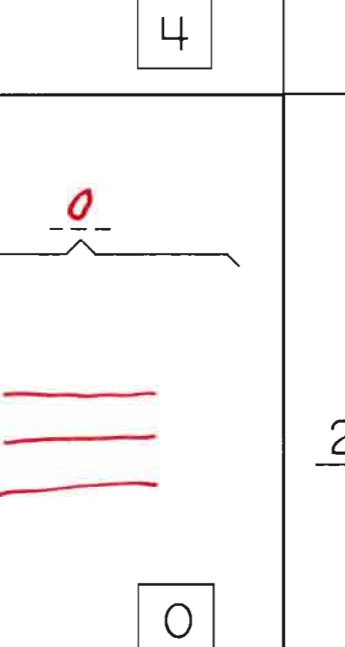
J. 

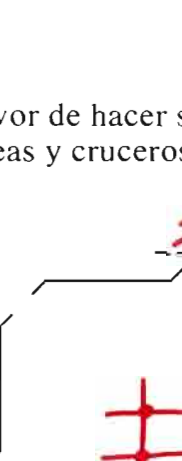
K. 

---

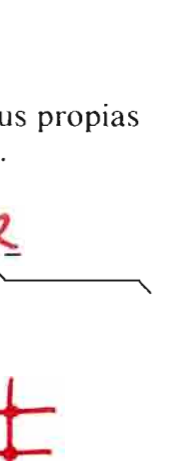
L. 

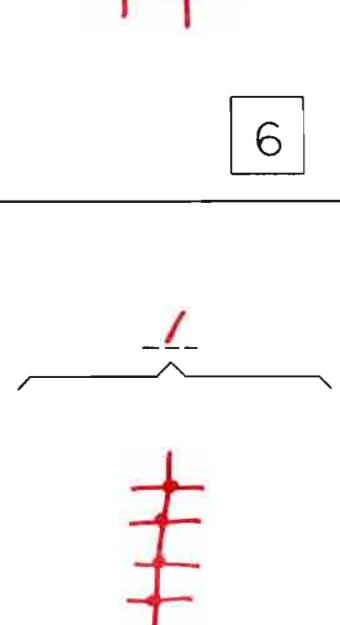
K. 

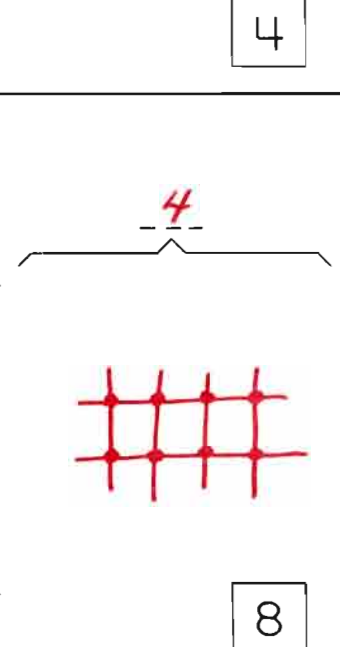
L. 

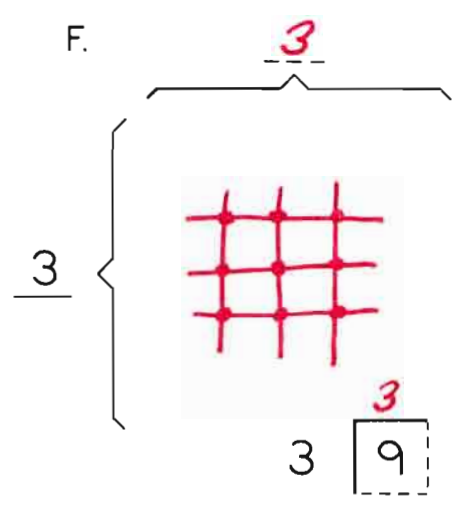
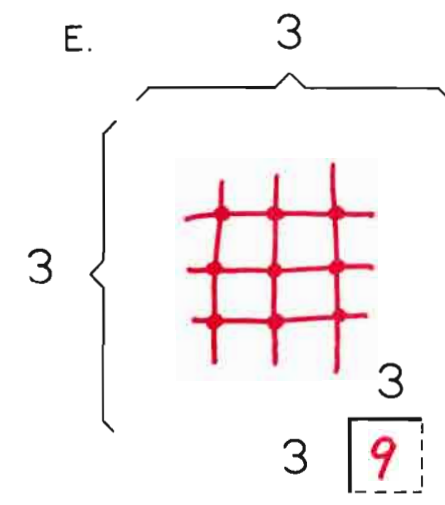
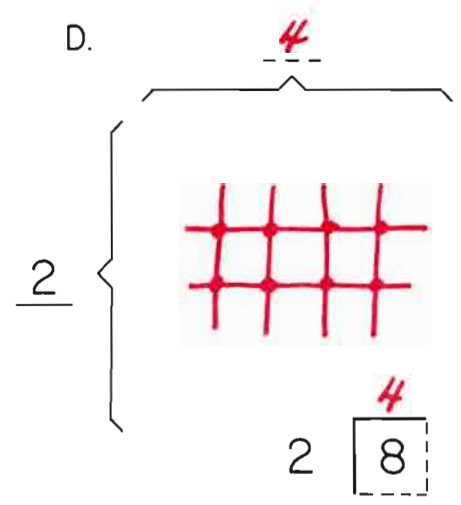
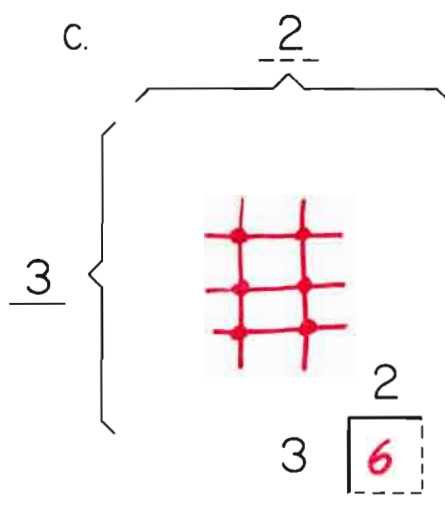
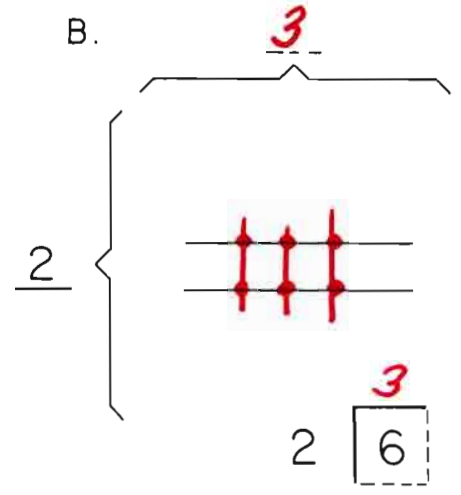
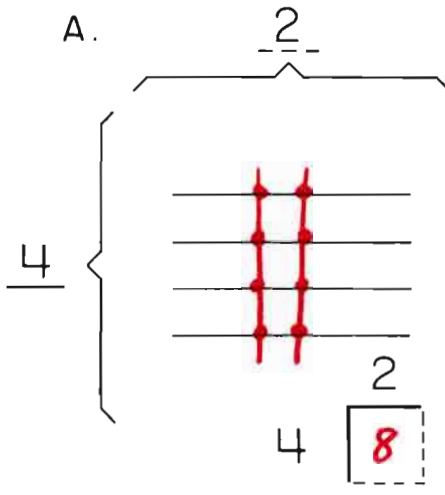
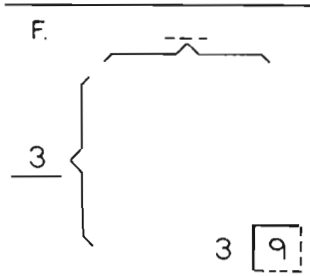
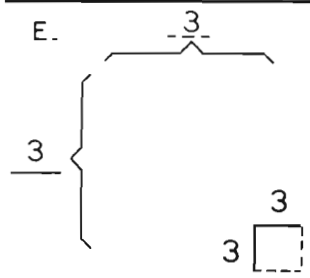
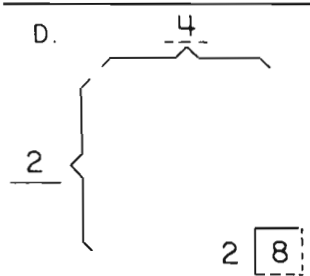
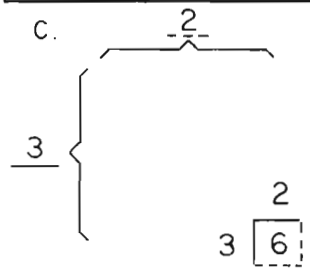
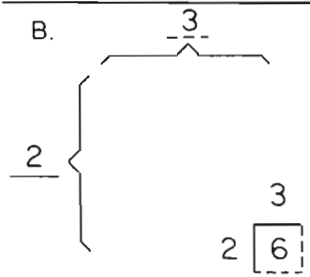
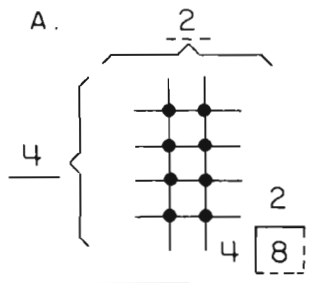



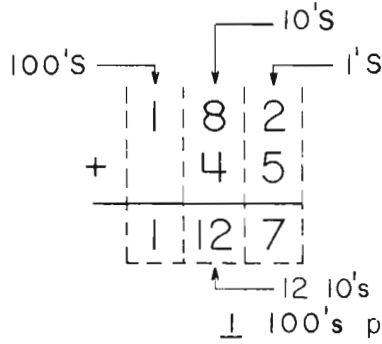
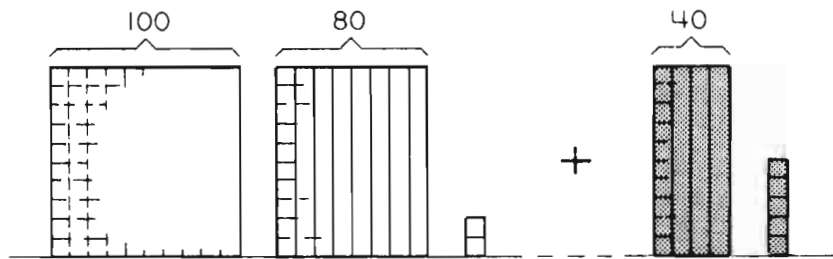

$$\begin{array}{r} 182 \\ + 45 \\ \hline 227 \end{array}$$

a.

$$\begin{array}{r} 182 \\ + 8 \\ \hline 190 \end{array} \quad \begin{array}{r} 182 \\ + 9 \\ \hline 191 \end{array} \quad \begin{array}{r} 182 \\ + 10 \\ \hline 192 \end{array}$$

$$\begin{array}{r} 182 \\ + 17 \\ \hline 199 \end{array}$$

Hundreds rafts, tensticks and loose beans to manipulate will continue to be helpful to some children.

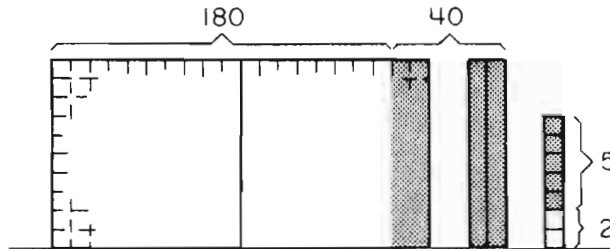

$$\begin{array}{r} 182 \\ + 45 \\ \hline 227 \end{array}$$

b.

$$\begin{array}{r} 182 \\ + 20 \\ \hline 202 \end{array} \quad \begin{array}{r} 182 \\ + 27 \\ \hline 209 \end{array} \quad \begin{array}{r} 182 \\ + 28 \\ \hline 210 \end{array}$$

$$\begin{array}{r} 182 \\ + 39 \\ \hline 221 \end{array}$$

a.

$$\begin{array}{r} 182 \\ + 8 \\ \hline 190 \end{array} \quad \begin{array}{r} 182 \\ + 9 \\ \hline 191 \end{array} \quad \begin{array}{r} 182 \\ + 10 \\ \hline 192 \end{array} \quad \begin{array}{r} 182 \\ + 17 \\ \hline 199 \end{array}$$

b.

$$\begin{array}{r} 182 \\ + 20 \\ \hline 202 \end{array} \quad \begin{array}{r} 182 \\ + 27 \\ \hline 209 \end{array} \quad \begin{array}{r} 182 \\ + 28 \\ \hline 210 \end{array} \quad \begin{array}{r} 182 \\ + 39 \\ \hline 221 \end{array}$$

c.

$$\begin{array}{r} 182 \\ + 100 \\ \hline 282 \end{array} \quad \begin{array}{r} 182 \\ + 30 \\ \hline 212 \end{array} \quad \begin{array}{r} 182 \\ + 108 \\ \hline 290 \end{array}$$

$$\begin{array}{r} 182 \\ + 130 \\ \hline 312 \end{array}$$

c.

$$\begin{array}{r} 182 \\ + 100 \\ \hline 282 \end{array} \quad \begin{array}{r} 182 \\ + 30 \\ \hline 212 \end{array} \quad \begin{array}{r} 182 \\ + 108 \\ \hline 290 \end{array} \quad \begin{array}{r} 182 \\ + 130 \\ \hline 312 \end{array}$$

See also: D.I. pp. 76-80

d.

$$\begin{array}{r} 227 \\ - 7 \\ \hline 220 \end{array} \quad \begin{array}{r} 227 \\ - 20 \\ \hline 207 \end{array} \quad \begin{array}{r} 227 \\ - 200 \\ \hline 27 \end{array}$$

$$\begin{array}{r} 227 \\ - 207 \\ \hline 20 \end{array}$$

e.

$$\begin{array}{r} 227 \\ - 5 \\ \hline 222 \end{array} \quad \begin{array}{r} 227 \\ - 10 \\ \hline 217 \end{array} \quad \begin{array}{r} 227 \\ - 105 \\ \hline 122 \end{array}$$

$$\begin{array}{r} 227 \\ - 123 \\ \hline 104 \end{array}$$

f.

$$\begin{array}{r} 227 \\ - 8 \\ \hline 219 \end{array} \quad \begin{array}{r} 227 \\ - 18 \\ \hline 209 \end{array} \quad \begin{array}{r} 227 \\ - 27 \\ \hline 200 \end{array}$$

$$\begin{array}{r} 227 \\ - 37 \\ \hline 190 \end{array}$$

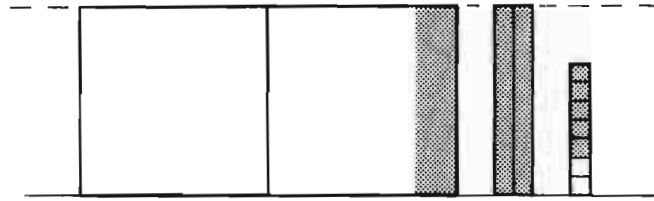

$$\begin{array}{r} 227 \\ - 45 \\ \hline 182 \end{array}$$

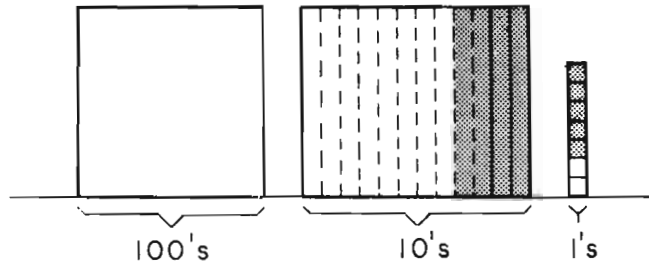
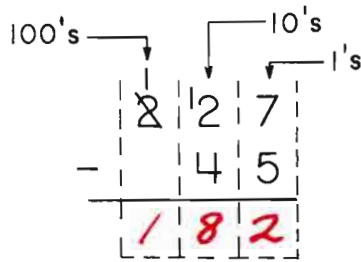

$$\begin{array}{r} 227 \\ - 45 \\ \hline 182 \end{array}$$

d.

$$\begin{array}{r} 227 \\ - 7 \\ \hline 220 \end{array} \quad \begin{array}{r} 227 \\ - 20 \\ \hline 207 \end{array} \quad \begin{array}{r} 227 \\ - 200 \\ \hline 27 \end{array} \quad \begin{array}{r} 227 \\ - 207 \\ \hline 20 \end{array}$$

e.

$$\begin{array}{r} 227 \\ - 5 \\ \hline 222 \end{array} \quad \begin{array}{r} 227 \\ - 10 \\ \hline 217 \end{array} \quad \begin{array}{r} 227 \\ - 105 \\ \hline 122 \end{array} \quad \begin{array}{r} 227 \\ - 123 \\ \hline 104 \end{array}$$

f.

$$\begin{array}{r} 227 \\ - 8 \\ \hline 219 \end{array} \quad \begin{array}{r} 227 \\ - 18 \\ \hline 209 \end{array} \quad \begin{array}{r} 227 \\ - 27 \\ \hline 200 \end{array} \quad \begin{array}{r} 227 \\ - 37 \\ \hline 190 \end{array}$$

See also: D.I. pp. 101-105

On Your Own. Usted Solo.

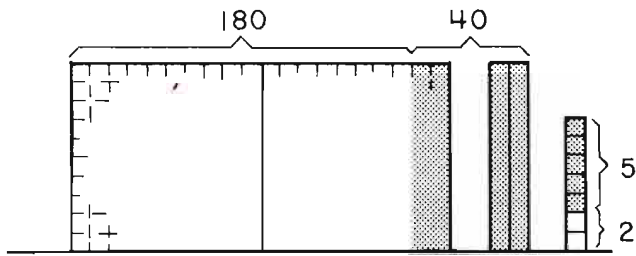

$$\begin{array}{r} 182 \\ + 45 \\ \hline 227 \end{array}$$

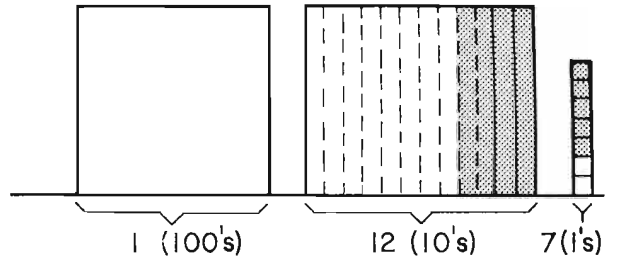

$$\begin{array}{r} 227 \\ - 45 \\ \hline 182 \end{array}$$

$$\begin{array}{r} 182 \\ + 10 \\ \hline 192 \end{array}$$

$$\begin{array}{r} 182 \\ + 17 \\ \hline 199 \end{array}$$

$$\begin{array}{r} 227 \\ - 10 \\ \hline 217 \end{array}$$

$$\begin{array}{r} 227 \\ - 147 \\ \hline 80 \end{array}$$

$$\begin{array}{r} 182 \\ + 28 \\ \hline 210 \end{array}$$

$$\begin{array}{r} 182 \\ + 39 \\ \hline 221 \end{array}$$

$$\begin{array}{r} 227 \\ - 18 \\ \hline 209 \end{array}$$

$$\begin{array}{r} 227 \\ - 123 \\ \hline 104 \end{array}$$

$$\begin{array}{r} 128 \\ + 52 \\ \hline 180 \end{array}$$

$$\begin{array}{r} 128 \\ + 135 \\ \hline 263 \end{array}$$

$$\begin{array}{r} 128 \\ - 109 \\ \hline 19 \end{array}$$



How do you feel?  
¿Cómo se siente?

Dear Parents,

This progress test shows you that your child can now work with addition and subtraction problems that require regrouping into the hundreds. There are pictures of the "place value" groupings on the test, as on the previous pages of this kind. The abstract idea of a hundred develops only with lots of exposure to the manipulation of a hundred things, and then to pictorial representations.

If you made some beanstick hundreds rafts as suggested in the B<sub>1</sub> book, you can use them here for manipulating the new step in the regrouping process that your child is now working with. Talk about

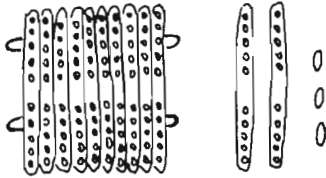

hundreds and tens is abstract talk, whereas working with hundreds rafts and tensticks is very "real" to the touch and sight. After using these, blocks of hundreds and tens drawn on paper are very "real" to see, and the knowledge is there that they refer to those concrete things (such as beans) that we know and have worked with.

In solving the problems on this check-up test, your child had to work with the idea that 10 tens is exactly the same as a hundred. Then the "trades" - regrouping a hundred from 10 tens and regrouping 10 tens from a hundred be made. This is sophisticated and the kind we use daily in our It may take your child much more of activities with confidence, so please encourage the use of counters and pictures as long as necessary. A positive attitude toward mathematics as a logical method of recording what we see and use in the real world is what is most important.

$$\begin{array}{r} 11 \\ 182 \\ + 28 \\ \hline 210 \end{array}$$

and had to  $\begin{array}{r} 11 \\ 227 \\ - 147 \\ \hline 80 \end{array}$  mathematics lives.

adult time to work these kinds

Again we remind ourselves and you that your child's attitude about math and about himself as a participant in the activities of math are the decisive factors in what is learned. Once again your warm support is welcomed and well appreciated.

Sincerely,

Please draw your own lines and crossing points.

Favor de hacer sus propias líneas y crucesos.

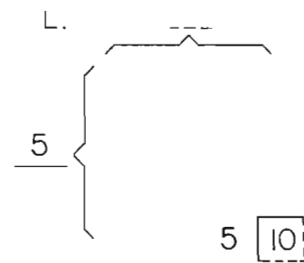
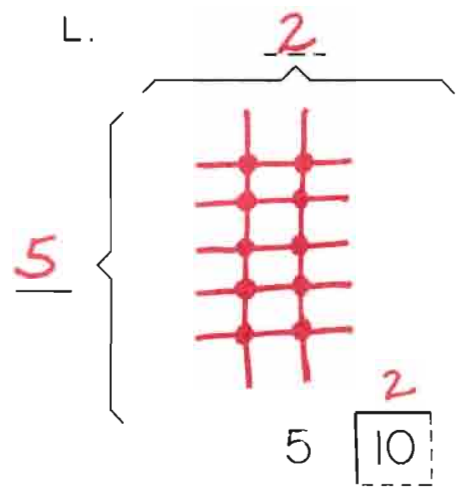
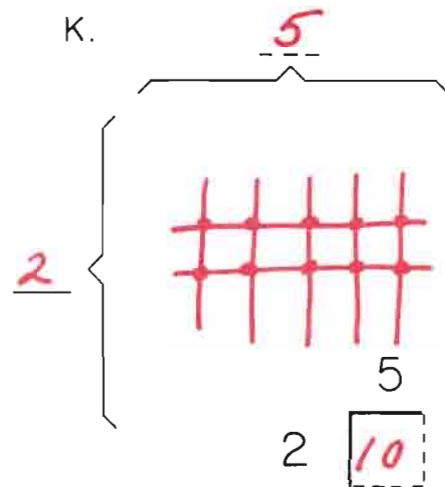
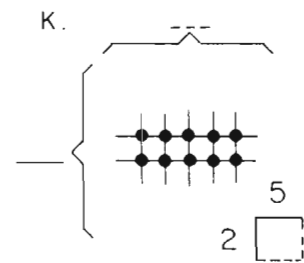
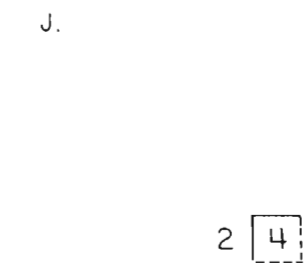
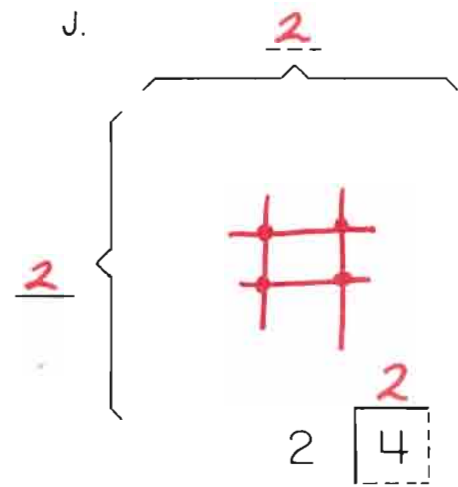
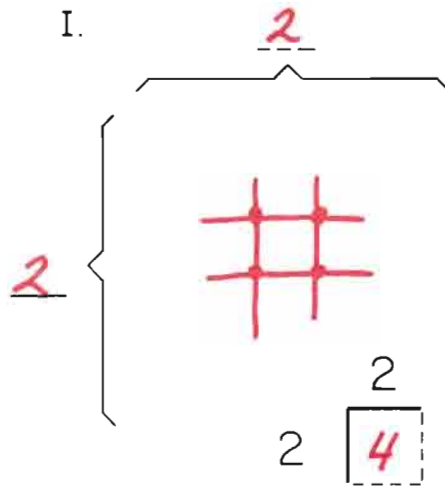
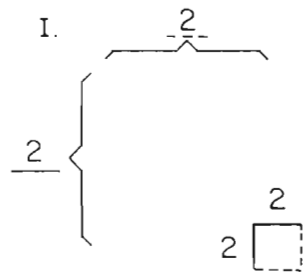
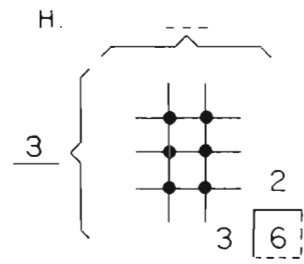
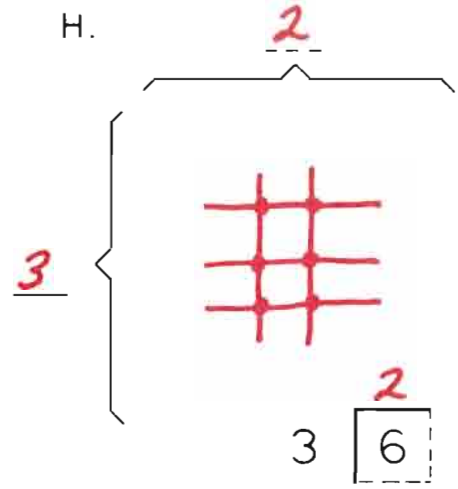
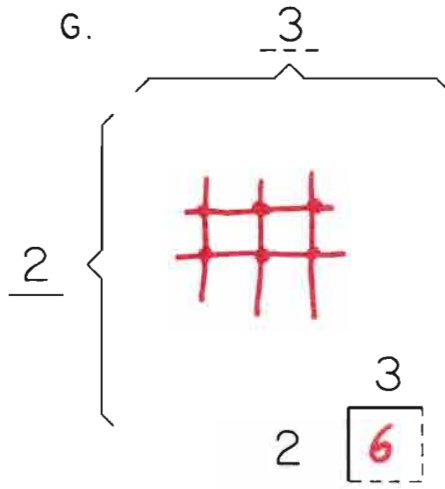
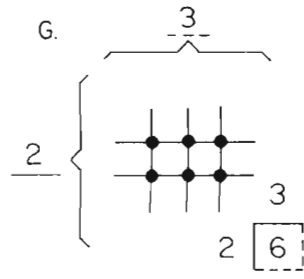

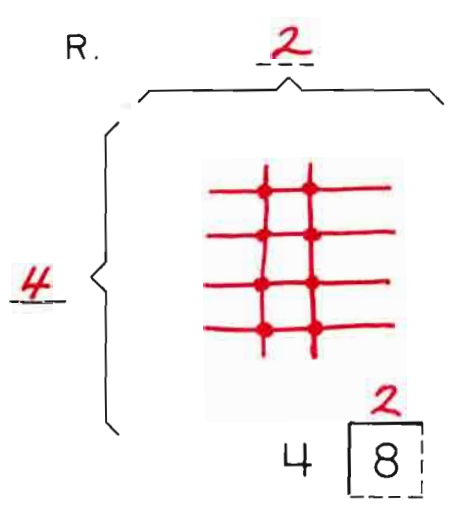
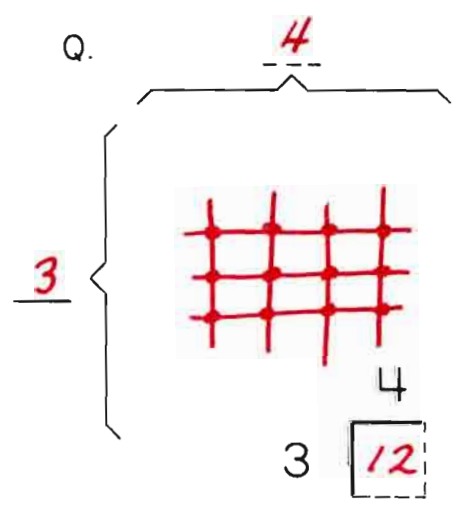
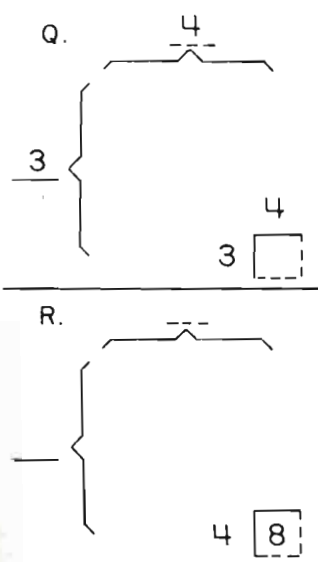
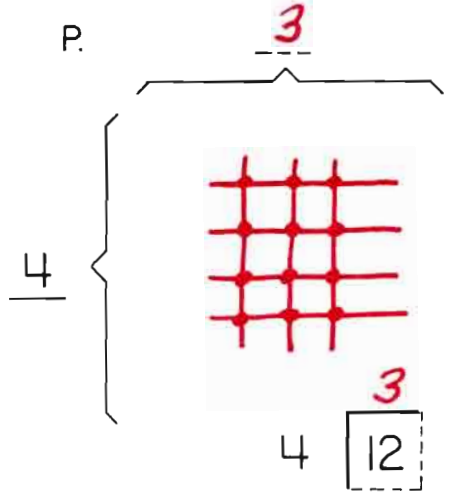
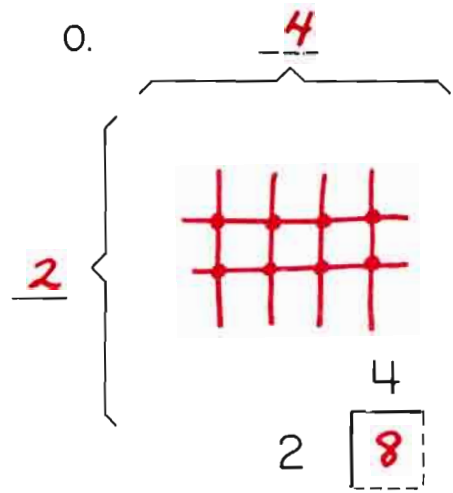
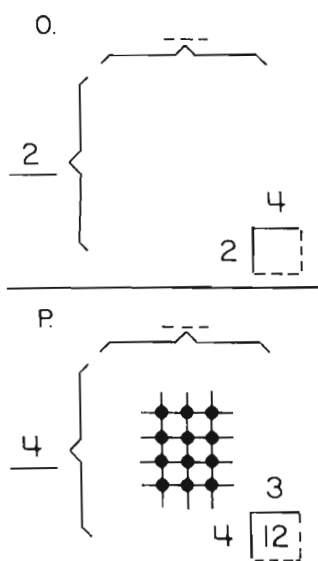
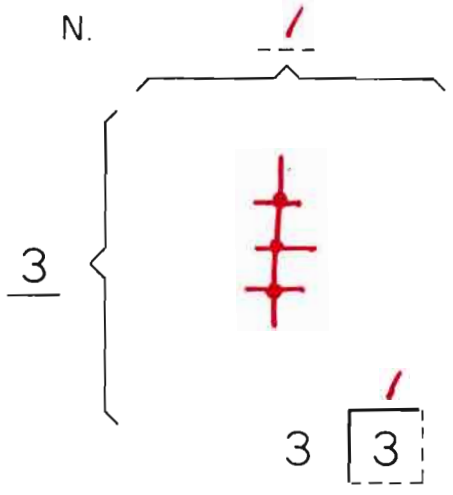
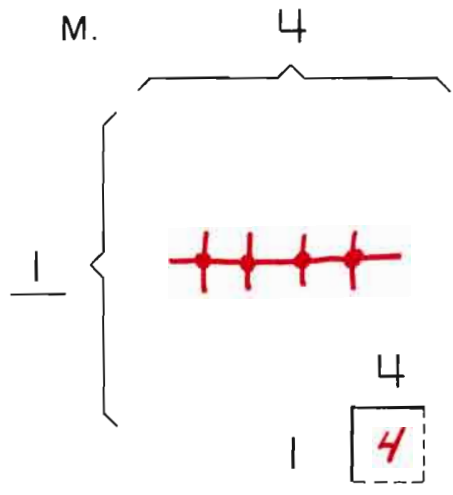
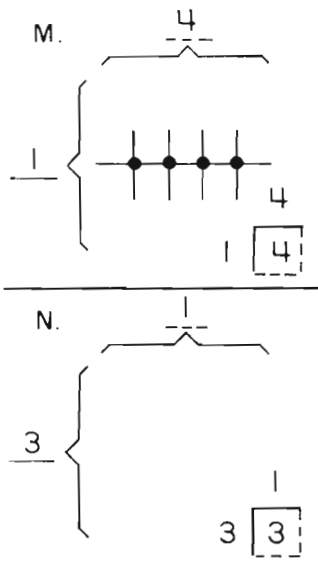



ABOVE ..... BELOW ..... and BETWEEN

ARRIBA ..... ABAJO ..... y ..... EN MEDIO

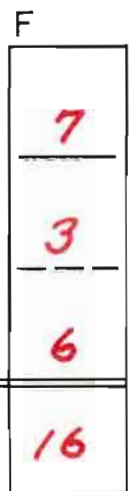
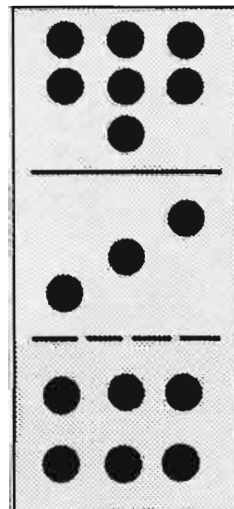
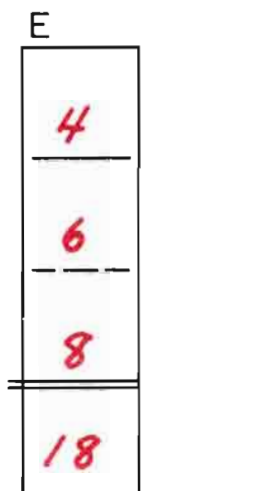
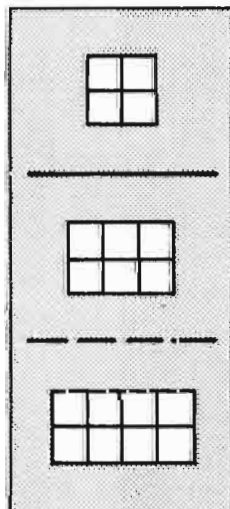
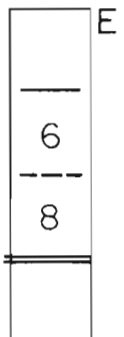
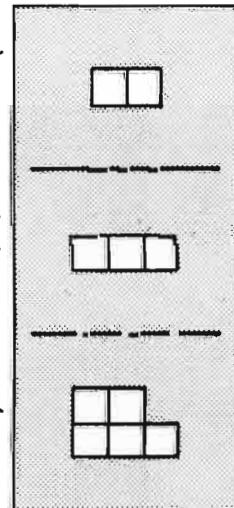
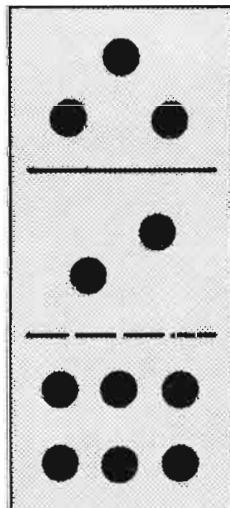
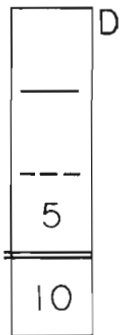
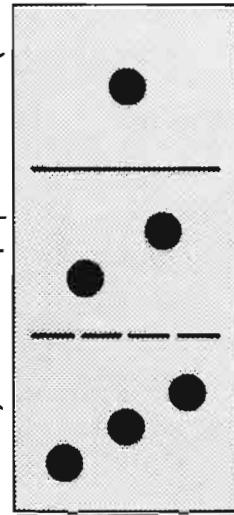
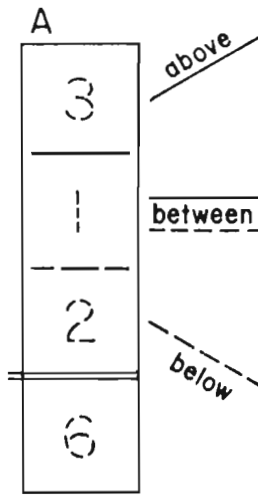
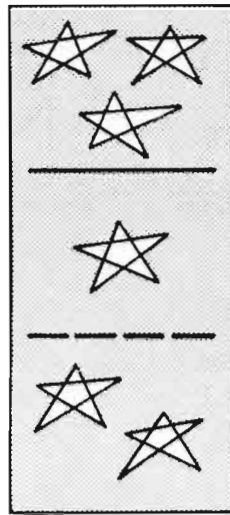
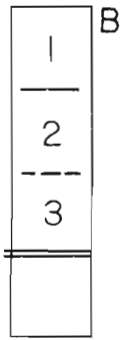
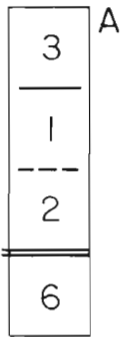



ABOVE.....BELOW..... and BETWEEN

ARRIBA.....ABAJO.....y.....EN MEDIO

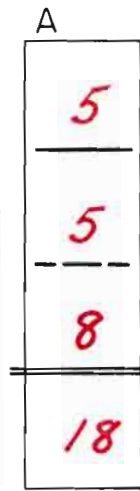
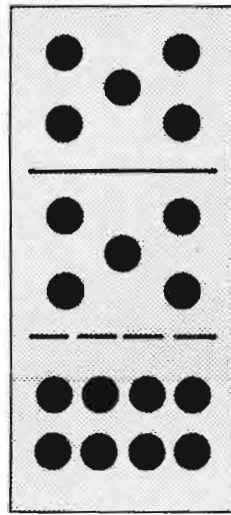
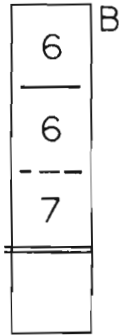
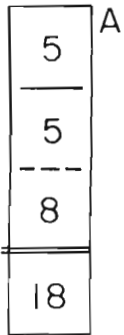

above  
between  
below

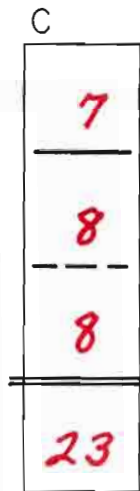
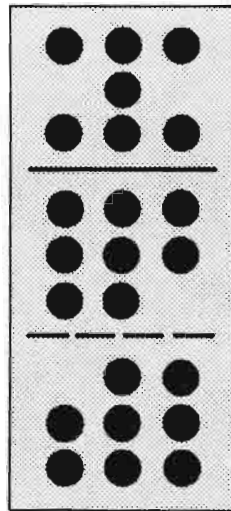
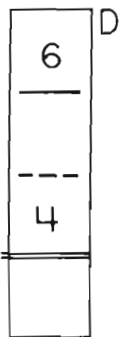
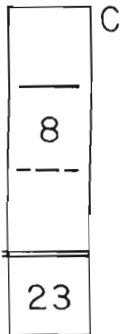
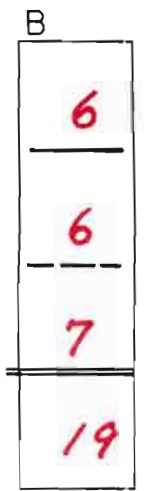
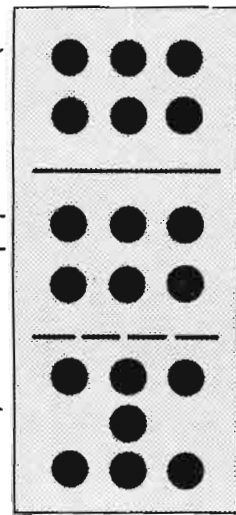

arriba  
en medio  
abajo

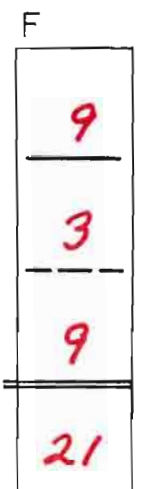
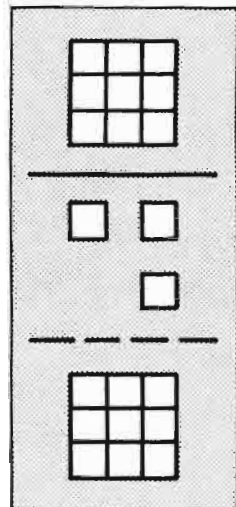
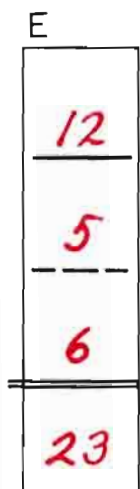
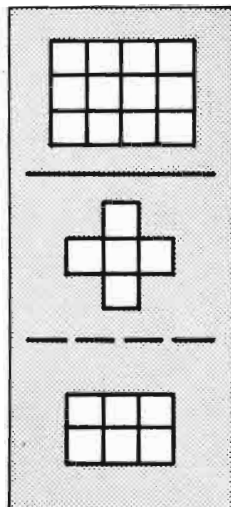
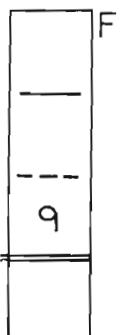
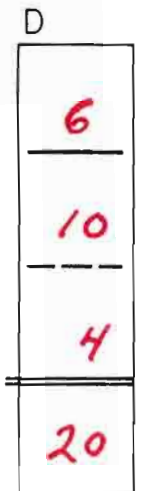
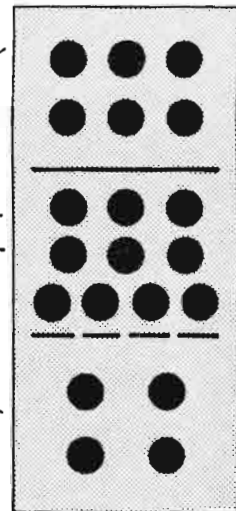

If you have not introduced the words "times" or "multiplied by" and "divided by" it can be done now to give definition to the symbols introduced on this page.

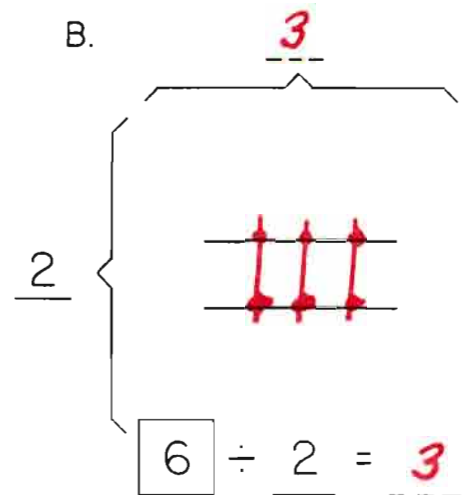
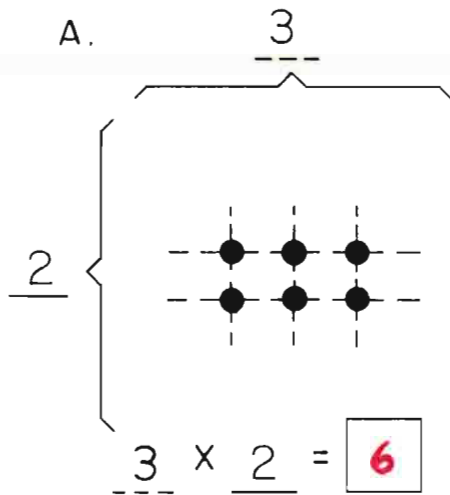
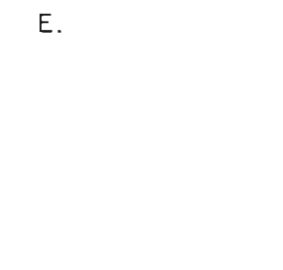
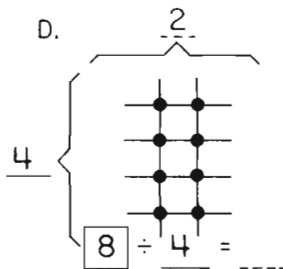
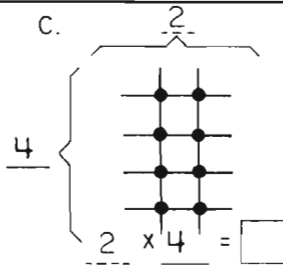
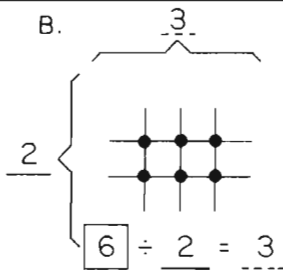
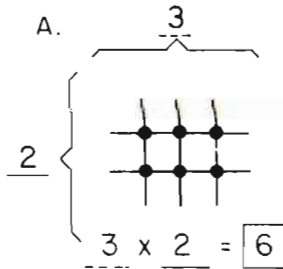

See also: D.I. pp. 40-44, 128-130

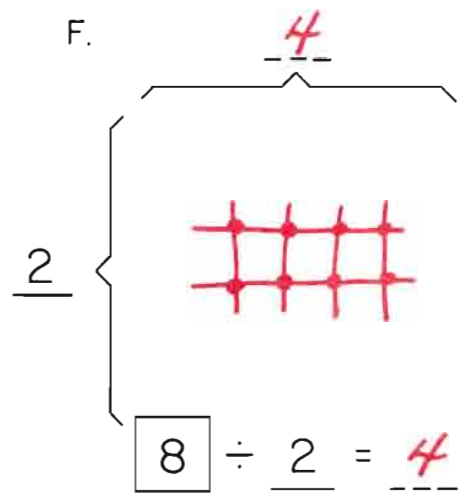
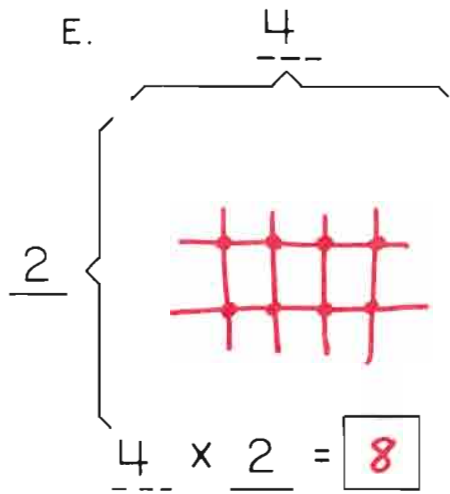
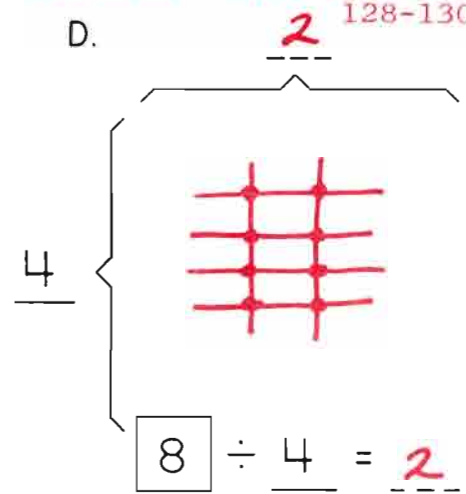
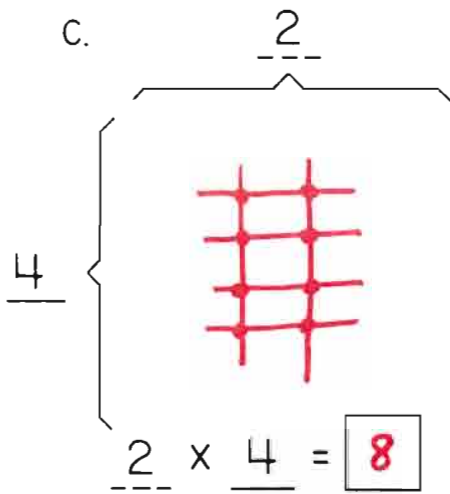

G.

$2 \times 3 = \square$

H.

$\square \div 3 = \square$

G.

$2 \times 3 = 6$

H.

$6 \div 3 = 2$

I.

$3 \times 3 = \square$

J.

$9 \div 3 = 3$

I.

$3 \times 3 = 9$

J.

$9 \div 3 = 3$

K.

$5 \times \square = \square$

L.

$10 \div 2 = \square$

K.

$5 \times 2 = 10$

L.

$10 \div 2 = 5$

Please draw a line to connect 2 numbers that add up to 10.

Favor de dibujar una línea para conectar 2 números que sumen 10.

$$\begin{array}{r} 5 \\ + 5 \\ \hline 12 \end{array}$$

$$\begin{array}{r} 5 \\ + 2 \\ \hline 12 \end{array}$$

$$\begin{array}{r} 8 \\ + 2 \\ \hline \end{array}$$

$$\begin{array}{r} 2 \\ + 3 \\ \hline 13 \end{array}$$

$$\begin{array}{r} 3 \\ + 8 \\ \hline \end{array}$$

$$\begin{array}{r} 5 \\ + 5 \\ \hline 12 \end{array}$$

$$\begin{array}{r} 5 \\ + 2 \\ \hline 12 \end{array}$$

$$\begin{array}{r} 8 \\ + 2 \\ \hline 13 \end{array}$$

$$\begin{array}{r} 2 \\ + 3 \\ \hline 13 \end{array}$$

$$\begin{array}{r} 3 \\ + 8 \\ \hline 13 \end{array}$$

$$\begin{array}{r} 7 \\ + 3 \\ \hline 15 \end{array}$$

$$\begin{array}{r} 6 \\ + 3 \\ \hline 12 \end{array}$$

$$\begin{array}{r} 7 \\ + 2 \\ \hline 12 \end{array}$$

$$\begin{array}{r} 6 \\ + 1 \\ \hline 16 \end{array}$$

$$\begin{array}{r} 9 \\ + 7 \\ \hline 16 \end{array}$$

$$\begin{array}{r} 7 \\ + 3 \\ \hline 15 \end{array}$$

$$\begin{array}{r} 6 \\ + 3 \\ \hline 16 \end{array}$$

$$\begin{array}{r} 7 \\ + 2 \\ \hline 12 \end{array}$$

$$\begin{array}{r} 6 \\ + 1 \\ \hline 16 \end{array}$$

$$\begin{array}{r} 9 \\ + 7 \\ \hline 17 \end{array}$$

$$\begin{array}{r} 4 \\ + 6 \\ \hline 13 \end{array}$$

$$\begin{array}{r} 6 \\ + 4 \\ \hline 19 \end{array}$$

$$\begin{array}{r} 4 \\ + 7 \\ \hline \end{array}$$

$$\begin{array}{r} 9 \\ + 1 \\ \hline 16 \end{array}$$

$$\begin{array}{r} 6 \\ + 2 \\ \hline 16 \end{array}$$

$$\begin{array}{r} 4 \\ + 6 \\ \hline 13 \end{array}$$

$$\begin{array}{r} 6 \\ + 4 \\ \hline 19 \end{array}$$

$$\begin{array}{r} 4 \\ + 7 \\ \hline 17 \end{array}$$

$$\begin{array}{r} 9 \\ + 1 \\ \hline 18 \end{array}$$

$$\begin{array}{r} 6 \\ + 2 \\ \hline 16 \end{array}$$

$$\begin{array}{r} 5 \\ + 5 \\ \hline 13 \end{array}$$

$$\begin{array}{r} 6 \\ + 2 \\ \hline 14 \end{array}$$

$$\begin{array}{r} 7 \\ + 3 \\ \hline 14 \end{array}$$

$$\begin{array}{r} 2 \\ + 3 \\ \hline 15 \end{array}$$

$$\begin{array}{r} 1 \\ + 2 \\ \hline 15 \end{array}$$

$$\begin{array}{r} 5 \\ + 2 \\ \hline 13 \end{array}$$

$$\begin{array}{r} 6 \\ + 2 \\ \hline 13 \end{array}$$

$$\begin{array}{r} 7 \\ + 3 \\ \hline 14 \end{array}$$

$$\begin{array}{r} 1 \\ + 2 \\ \hline 14 \end{array}$$

$$\begin{array}{r} 1 \\ + 2 \\ \hline 15 \end{array}$$

$$\begin{array}{r} 3 \\ + 4 \\ \hline 19 \end{array}$$

$$\begin{array}{r} 5 \\ + 3 \\ \hline 19 \end{array}$$

$$\begin{array}{r} 5 \\ + 9 \\ \hline \end{array}$$

$$\begin{array}{r} 2 \\ + 3 \\ \hline 19 \end{array}$$

$$\begin{array}{r} 4 \\ + 5 \\ \hline 20 \end{array}$$

$$\begin{array}{r} 3 \\ + 4 \\ \hline 19 \end{array}$$

$$\begin{array}{r} 5 \\ + 3 \\ \hline 19 \end{array}$$

$$\begin{array}{r} 5 \\ + 9 \\ \hline 18 \end{array}$$

$$\begin{array}{r} 2 \\ + 3 \\ \hline 17 \end{array}$$

$$\begin{array}{r} 6 \\ + 4 \\ \hline 20 \end{array}$$

M.

$1 \times 5 = \square$

N.

$12 \div 2 = 6$

M.

$5 \times 5 = 5$

N.

$12 \div 2 = 6$

O.

$2 \times 5 = \square$

P.

$12 \div 3 = \square$

O.

$2 \times 5 = 10$

P.

$12 \div 3 = 4$

Q.

$3 \times 5 = \square$

R.

$12 \div 4 = \square$

Q.

$3 \times 5 = 15$

R.

$12 \div 4 = 3$

On Your Own.

Usted Solo.

$4 \times 3 = 12$

$12 \div 3 = 4$

$2 \overline{) 10}$

$2 \overline{) 8}$

$5 \times 1 = 5$

$3 \div 1 = 3$

$4 \overline{) 16}$

$3 \overline{) 15}$

$4 \times 4 = 16$

$15 \div 3 = 5$



How do you feel?  
¿Cómo se siente?



Dear Parents,

Your child has been doing lots of multiplication and division activities and on this check-up exercise has recorded those processes in the standard notation forms - some without any picture to refer to. It's important to mention here, as was mentioned in the A<sub>2</sub> level book, that all children understand the "concepts" of multiplication and division before they come to school. They've seen that when 3 children each have 2 toys there are 6 toys, that 2 groups of 5 fingers are 10 fingers, and they've shared 8 cookies amongst 4 friends. Now they are learning to record this knowledge in the special shorthand of arithmetic.

The "lines and crossing points" sketches here are an interesting and very workable way of representing the operations of multiplication and division. There is nothing scary or mysterious about those big words they've heard. There are 4 crossing points in each of 3 rows ( $4 \times 3 = 12$ ) just as 4 children with 3 cookies each results in 12 cookies. Math is reasonable!

You can help with this at home by simply discussing everyday sorts of examples and perhaps writing some down in the standard forms your child is learning. You can come up with lots of fun ideas - i.e. there are 4 people sitting at the table, each person has 2 hands, so how many hands are there at the table; each person has 3 pieces of silverware, so how many pieces are there on the table; there are a dozen cookies in the package, so what's each person's share, etc.

Pleasure and self-confidence can and should be high for your child now. Let's work to keep it that way with lots of enthusiastic and fun support!

Sincerely,



$$\begin{array}{r} 12 \\ + 7 \\ \hline 19 \\ + 10 \\ \hline 29 \end{array} \text{ Total}$$

$$\begin{array}{r} 10 \\ + 16 \\ \hline 40 \end{array}$$

$$\begin{array}{r} 15 \\ + 50 \\ \hline 65 \end{array}$$

$$\begin{array}{r} 14 \\ + 20 \\ \hline 34 \\ + 18 \\ \hline 52 \end{array}$$

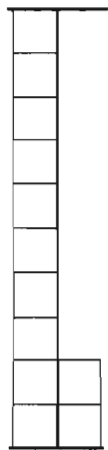

a.

+

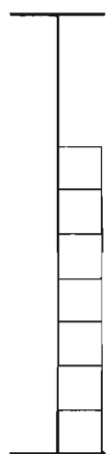

b.

+

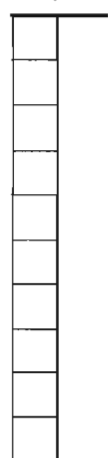

c.

$$\begin{array}{r} 12 \\ + 7 \\ \hline 19 \\ + 10 \\ \hline 29 \end{array} \text{ Total}$$

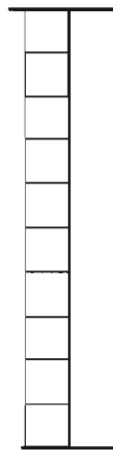

d.

+



e.

+

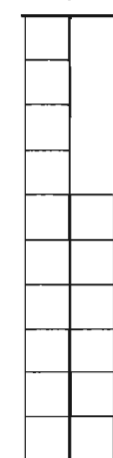

f.

$$\begin{array}{r} 10 \\ + 14 \\ \hline 24 \\ + 16 \\ \hline 40 \end{array}$$



g.

+

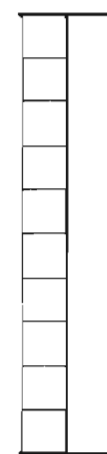

h.

+

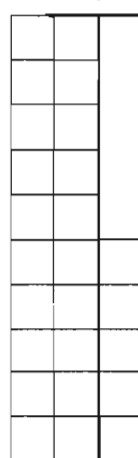

i.

$$\begin{array}{r} 15 \\ + 10 \\ \hline 25 \\ + 25 \\ \hline 50 \end{array}$$

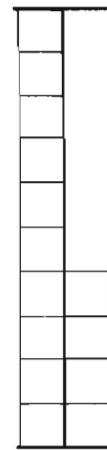

j.

+

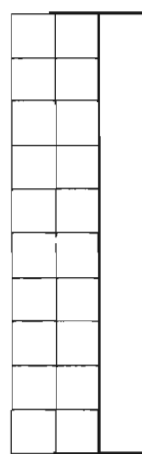

k.

+



l.

$$\begin{array}{r} 14 \\ + 20 \\ \hline 34 \\ + 18 \\ \hline 52 \end{array}$$

Please fill in the missing numbers and connect 2 numbers that add up to 10.

Favor de poner los números que faltan y de conectar dos números que den un total de 10.

$$\begin{array}{r} 5 \\ + 2 \\ \hline 12 \end{array}$$

$$\begin{array}{r} 5 \\ + 5 \\ \hline 12 \end{array}$$

$$\begin{array}{r} 8 \\ + 2 \\ \hline \end{array}$$

$$\begin{array}{r} 2 \\ + 3 \\ \hline 13 \end{array}$$

$$\begin{array}{r} 3 \\ + 8 \\ \hline 13 \end{array}$$

$$\begin{array}{r} 5 \\ + 2 \\ \hline 12 \end{array}$$

$$\begin{array}{r} 5 \\ + 5 \\ \hline 12 \end{array}$$

$$\begin{array}{r} 8 \\ + 3 \\ \hline 13 \end{array}$$

$$\begin{array}{r} 2 \\ + 8 \\ \hline 13 \end{array}$$

$$\begin{array}{r} 3 \\ + 2 \\ \hline 13 \end{array}$$

$$\begin{array}{r} 7 \\ + 3 \\ \hline 15 \end{array}$$

$$\begin{array}{r} 6 \\ + 7 \\ \hline \end{array}$$

$$\begin{array}{r} 7 \\ + 2 \\ \hline 12 \end{array}$$

$$\begin{array}{r} 6 \\ + 9 \\ \hline 16 \end{array}$$

$$\begin{array}{r} 7 \\ + 1 \\ \hline 17 \end{array}$$

$$\begin{array}{r} 7 \\ + 5 \\ \hline 15 \end{array}$$

$$\begin{array}{r} 6 \\ + 7 \\ \hline 16 \end{array}$$

$$\begin{array}{r} 7 \\ + 3 \\ \hline 12 \end{array}$$

$$\begin{array}{r} 6 \\ + 9 \\ \hline 16 \end{array}$$

$$\begin{array}{r} 9 \\ + 7 \\ \hline 17 \end{array}$$

$$\begin{array}{r} 4 \\ + 3 \\ \hline 13 \end{array}$$

$$\begin{array}{r} 6 \\ + 4 \\ \hline 19 \end{array}$$

$$\begin{array}{r} 4 \\ + 7 \\ \hline 17 \end{array}$$

$$\begin{array}{r} 9 \\ + 8 \\ \hline 18 \end{array}$$

$$\begin{array}{r} 6 \\ + 2 \\ \hline 16 \end{array}$$

$$\begin{array}{r} 4 \\ + 3 \\ \hline 13 \end{array}$$

$$\begin{array}{r} 6 \\ + 9 \\ \hline 19 \end{array}$$

$$\begin{array}{r} 4 \\ + 7 \\ \hline 17 \end{array}$$

$$\begin{array}{r} 9 \\ + 8 \\ \hline 18 \end{array}$$

$$\begin{array}{r} 6 \\ + 2 \\ \hline 16 \end{array}$$

$$\begin{array}{r} 5 \\ + 2 \\ \hline 13 \end{array}$$

$$\begin{array}{r} 6 \\ + 1 \\ \hline 13 \end{array}$$

$$\begin{array}{r} 7 \\ + 3 \\ \hline 10 \end{array}$$

$$\begin{array}{r} 3 \\ + 8 \\ \hline 14 \end{array}$$

$$\begin{array}{r} 2 \\ + 3 \\ \hline 5 \end{array}$$

$$\begin{array}{r} 5 \\ + 2 \\ \hline 13 \end{array}$$

$$\begin{array}{r} 6 \\ + 1 \\ \hline 13 \end{array}$$

$$\begin{array}{r} 7 \\ + 3 \\ \hline 14 \end{array}$$

$$\begin{array}{r} 1 \\ + 8 \\ \hline 14 \end{array}$$

$$\begin{array}{r} 1 \\ + 2 \\ \hline 3 \end{array}$$

$$\begin{array}{r} 4 \\ + 5 \\ \hline 19 \end{array}$$

$$\begin{array}{r} 5 \\ + 3 \\ \hline 19 \end{array}$$

$$\begin{array}{r} 5 \\ + 3 \\ \hline 18 \end{array}$$

$$\begin{array}{r} 2 \\ + 8 \\ \hline 17 \end{array}$$

$$\begin{array}{r} 6 \\ + 4 \\ \hline 20 \end{array}$$

$$\begin{array}{r} 3 \\ + 4 \\ \hline 7 \end{array}$$

$$\begin{array}{r} 5 \\ + 3 \\ \hline 8 \end{array}$$

$$\begin{array}{r} 5 \\ + 9 \\ \hline 18 \end{array}$$

$$\begin{array}{r} 2 \\ + 3 \\ \hline 5 \end{array}$$

$$\begin{array}{r} 6 \\ + 4 \\ \hline 10 \end{array}$$

$$\begin{array}{r}
 10 \text{ m.} \\
 20 \text{ n.} \\
 + \quad \quad \text{o.} \\
 \hline
 40 \text{ Total}
 \end{array}$$

$$\begin{array}{r}
 15 \text{ p.} \\
 3 \text{ q.} \\
 + 13 \text{ r.} \\
 \hline
 40
 \end{array}$$

$$\begin{array}{r}
 19 \text{ s.} \\
 1 \text{ t.} \\
 + 21 \text{ u.} \\
 \hline
 50
 \end{array}$$

$$\begin{array}{r}
 25 \text{ v.} \\
 25 \text{ x.} \\
 + 25 \text{ w.} \\
 \hline
 \quad \quad \quad
 \end{array}$$

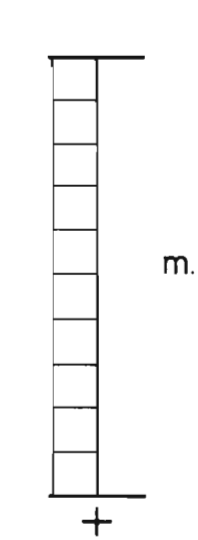

m.

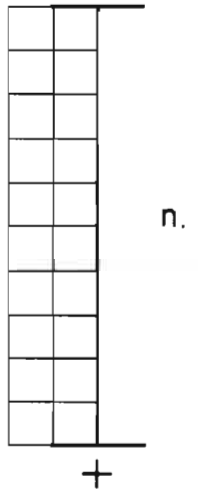

n.

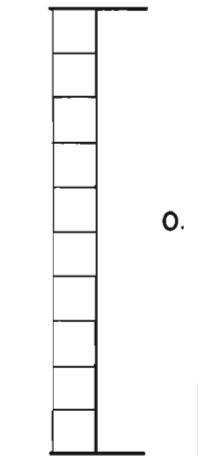

o.

$$\begin{array}{r}
 10 \text{ m.} \\
 20 \text{ n.} \\
 10 \text{ o.} \\
 \hline
 40 \text{ Total}
 \end{array}$$

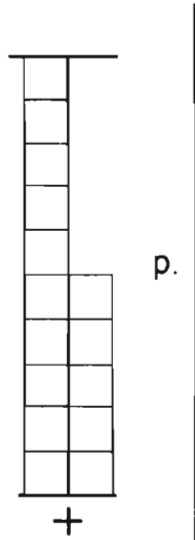

p.

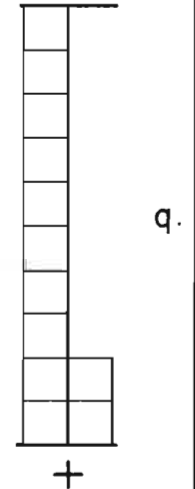

q.

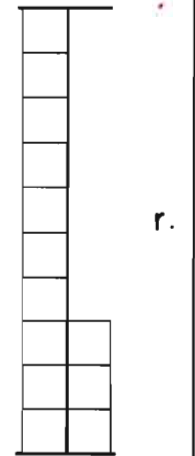

r.

$$\begin{array}{r}
 15 \text{ p.} \\
 12 \text{ q.} \\
 + 13 \text{ r.} \\
 \hline
 40
 \end{array}$$

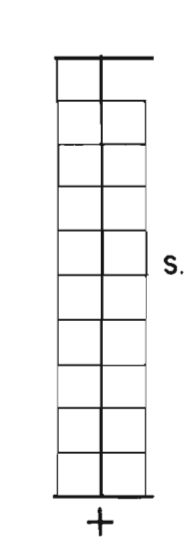

s.

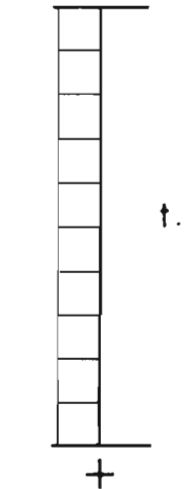

t.

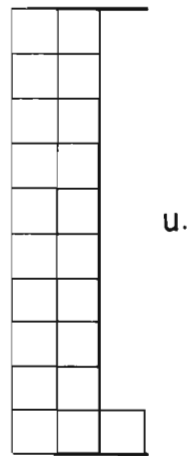

u.

$$\begin{array}{r}
 19 \text{ s.} \\
 10 \text{ t.} \\
 + 21 \text{ u.} \\
 \hline
 50
 \end{array}$$

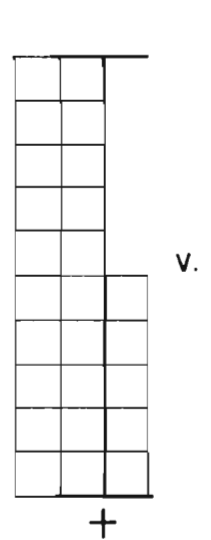

v.

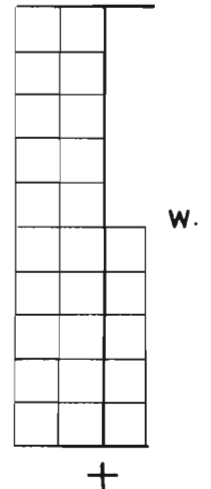

w.

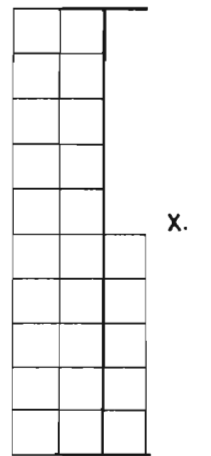

x.

$$\begin{array}{r}
 25 \text{ v.} \\
 25 \text{ w.} \\
 + 25 \text{ x.} \\
 \hline
 75
 \end{array}$$

Please draw your own lines and crossing points.

Favor de hacer sus propias líneas y cruces.

A.  $\overbrace{\quad\quad\quad}^4$   
 $\underbrace{\quad}_3$   
 $4 \times 3 = \square$

A.  $\overbrace{\quad\quad\quad}^4$   
 $\underbrace{\quad}_3$   
 $4 \times 3 = \boxed{12}$

B.  $\overbrace{\quad\quad\quad}^4$   
 $\underbrace{\quad}_3$   
 $\boxed{12} \div 3 = \underline{4}$

B.  $\overbrace{\quad\quad\quad}^{\quad}$   
 $\underbrace{\quad}_3$   
 $\boxed{12} \div 3 = \underline{4}$

C.  $\overbrace{\quad\quad\quad}^5$   
 $\underbrace{\quad}_1$   
 $5 \times 1 = \square$

C.  $\overbrace{\quad\quad\quad}^5$   
 $\underbrace{\quad}_1$   
 $5 \times 1 = \boxed{5}$

D.  $\overbrace{\quad\quad\quad}^3$   
 $\underbrace{\quad}_1$   
 $\boxed{3} \div 1 = \underline{3}$

D.  $\overbrace{\quad\quad\quad}^{\quad}$   
 $\underbrace{\quad}_1$   
 $\boxed{3} \div 1 = \underline{3}$

E.  $\overbrace{\quad\quad\quad}^4$   
 $\underbrace{\quad}_\quad$   
 $4 \times 4 = \square$

E.  $\overbrace{\quad\quad\quad}^4$   
 $\underbrace{\quad}_4$   
 $4 \times 4 = \boxed{16}$

F.  $\overbrace{\quad\quad\quad}^5$   
 $\underbrace{\quad}_3$   
 $\boxed{15} \div 3 = \underline{5}$

F.  $\overbrace{\quad\quad\quad}^{\quad}$   
 $\underbrace{\quad}_3$   
 $\boxed{15} \div 3 = \underline{\quad}$

$$\begin{array}{r} 1 \\ 1 \quad 2 \\ \hline + 1 \quad 3 \\ \hline 4 \quad 3 \end{array}$$

$$\begin{array}{r} 2 \\ 9 \\ \hline + 1 \quad 2 \\ \hline 3 \quad 0 \end{array}$$

$$\begin{array}{r} 2 \\ 1 \quad 7 \\ \hline + 1 \quad 7 \\ \hline 5 \quad 1 \end{array}$$

$$\begin{array}{r} 1 \quad 6 \\ 2 \quad 4 \\ \hline + 2 \quad 5 \\ \hline \end{array}$$

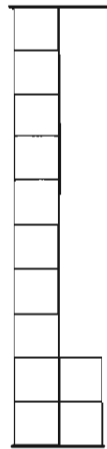

A.

+



B.

+



C.

$$\begin{array}{r} 1 \quad 2 \\ \hline + 1 \quad 3 \\ \hline 4 \quad 3 \end{array}$$

$$\begin{array}{r} 1 \quad 8 \\ \hline + 1 \quad 3 \\ \hline 4 \quad 3 \end{array}$$

$$\begin{array}{r} + 1 \quad 3 \\ \hline 4 \quad 3 \end{array}$$

$$4 \quad 3$$



D.

+

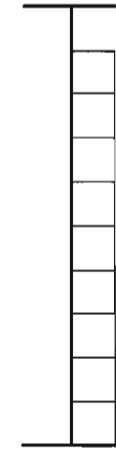

E.

+

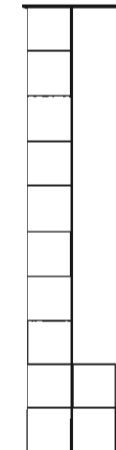

F.

$$\begin{array}{r} 2 \quad 9 \\ \hline + 1 \quad 2 \\ \hline 3 \quad 0 \end{array}$$

$$\begin{array}{r} + 1 \quad 2 \\ \hline 3 \quad 0 \end{array}$$

$$3 \quad 0$$



G.

+



H.

+

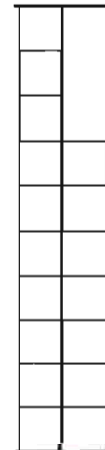

I.

$$\begin{array}{r} 2 \\ 1 \quad 7 \\ \hline + 1 \quad 7 \\ \hline 5 \quad 1 \end{array}$$

$$\begin{array}{r} + 1 \quad 7 \\ \hline 5 \quad 1 \end{array}$$

$$5 \quad 1$$



J.

+

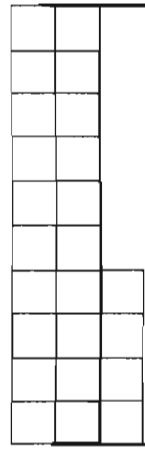

K.

+

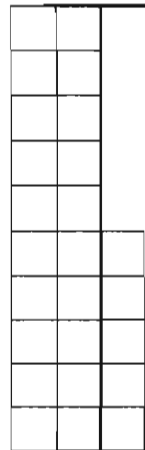

L.

$$\begin{array}{r} 1 \\ 1 \quad 6 \\ \hline + 2 \quad 5 \\ \hline 2 \quad 4 \end{array}$$

$$\begin{array}{r} + 2 \quad 5 \\ \hline 2 \quad 4 \end{array}$$

$$6 \quad 5$$

10 (1's)

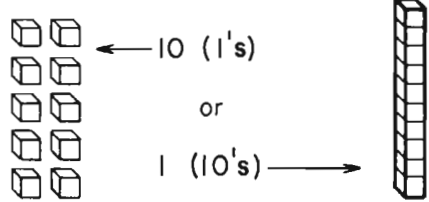
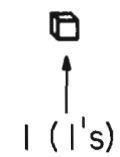

10 1's in each sketch en cada dibujo

100 1's

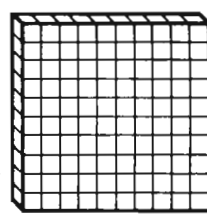
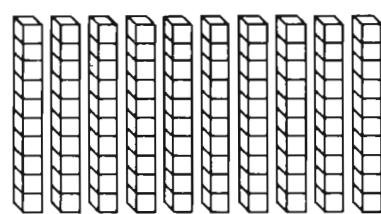

100 1's in each sketch en cada dibujo

1,000 1's

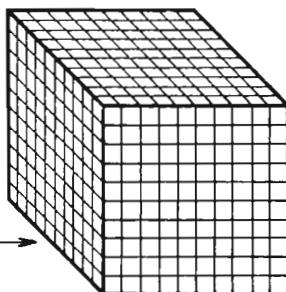
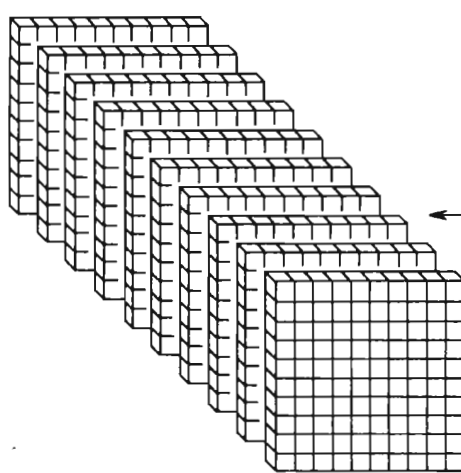

1,000 1's in each sketch en cada dibujo

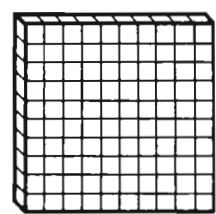
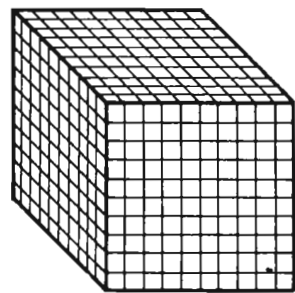

1,000

100

10

1

10 1

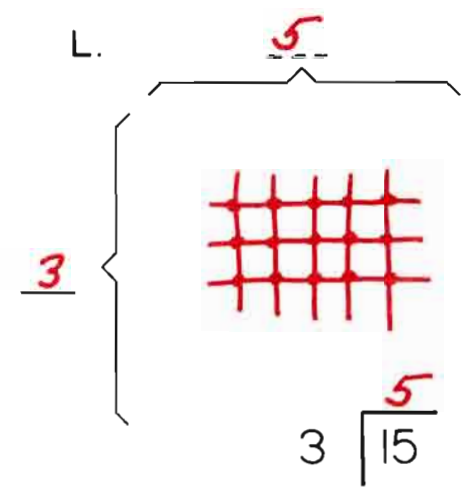
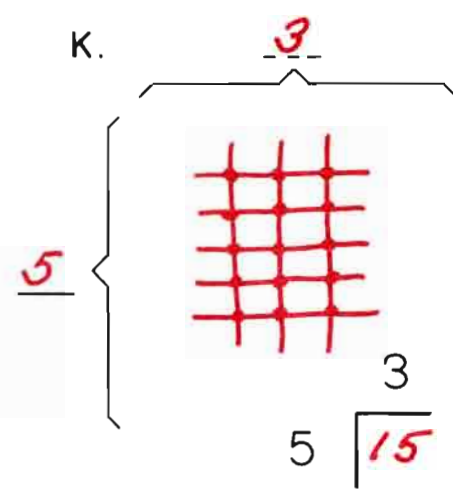
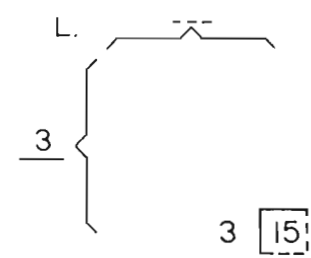
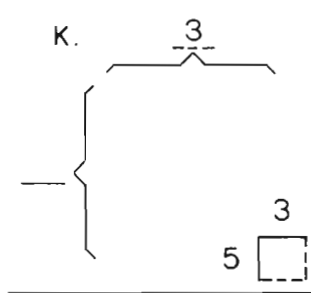
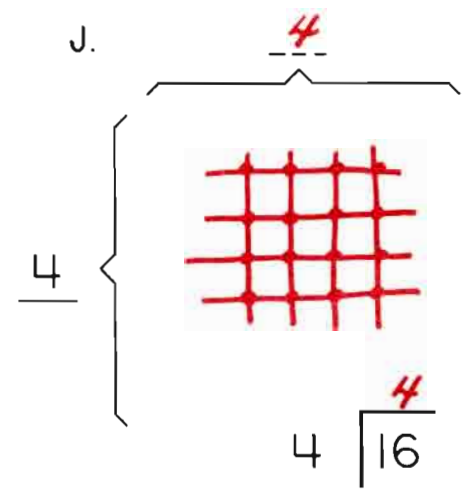
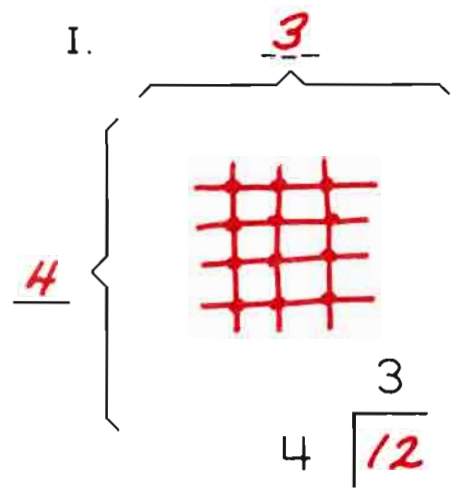
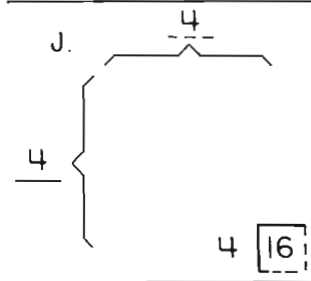
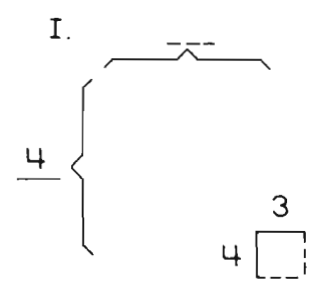
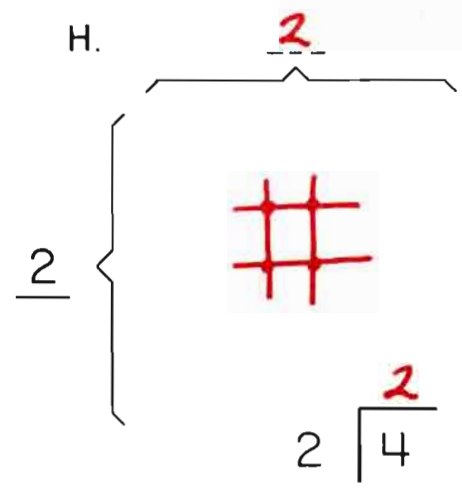
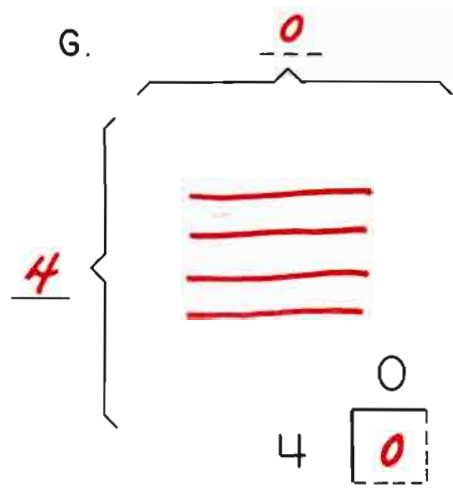
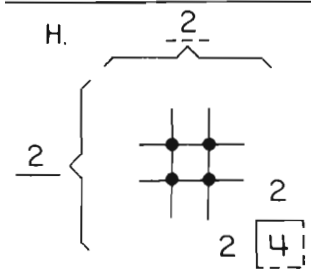
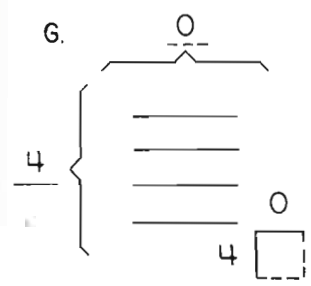



$$\begin{array}{r} 18 \\ 27 \\ +26 \\ \hline \hline \end{array}$$

$$\begin{array}{r} 39 \\ 24 \\ +35 \\ \hline \hline \end{array}$$

M.

P.

N.

Q.

O.

R.

$$\begin{array}{r} 2 \\ 18 \\ 27 \\ +26 \\ \hline \hline 71 \end{array}$$

M.

N.

O.

$$\begin{array}{r} 1 \\ 39 \\ 24 \\ +35 \\ \hline \hline 98 \end{array}$$

P.

Q.

R.

$$\begin{array}{r} 1 \\ 14 \\ 20 \\ +18 \\ \hline \hline 52 \end{array}$$

$$\begin{array}{r} 12 \\ 7 \\ +10 \\ \hline \hline 29 \end{array}$$

$$\begin{array}{r} 10 \\ 20 \\ +10 \\ \hline \hline 40 \end{array}$$

$$\begin{array}{r} 1 \\ 15 \\ 12 \\ +13 \\ \hline \hline 40 \end{array}$$

$$\begin{array}{r} 2 \\ 17 \\ 17 \\ +17 \\ \hline \hline 51 \end{array}$$

$$\begin{array}{r} 1 \\ 12 \\ 18 \\ +13 \\ \hline \hline 43 \end{array}$$

Please make up examples.

Favor de hacer ejemplos.

+ \_\_\_\_\_

+ \_\_\_\_\_

+ \_\_\_\_\_

+ \_\_\_\_\_

+ \_\_\_\_\_

+ \_\_\_\_\_

+ \_\_\_\_\_

+ \_\_\_\_\_

+ \_\_\_\_\_

+ \_\_\_\_\_

+ \_\_\_\_\_

+ \_\_\_\_\_

+ \_\_\_\_\_

+ \_\_\_\_\_

+ \_\_\_\_\_

+ \_\_\_\_\_

On Your Own.

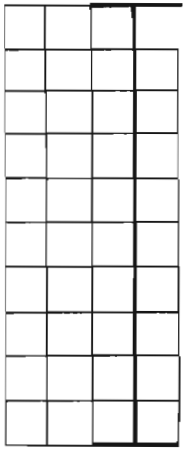

+

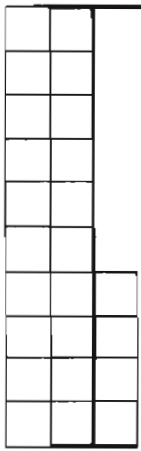

+

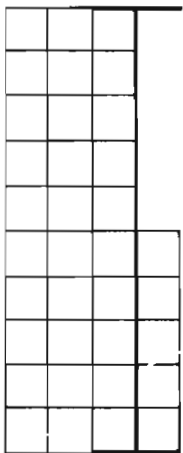

$$\begin{array}{r} \textcircled{1} \quad 39 \\ \quad 24 \\ \hline + 35 \\ \hline 98 \end{array}$$



+

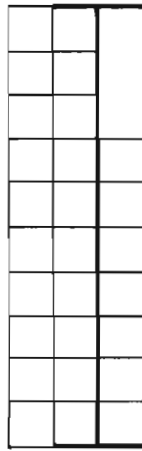

+



$$\begin{array}{r} \textcircled{2} \quad 18 \\ \quad 27 \\ \hline + 26 \\ \hline 71 \end{array}$$

Usted Solo.



+

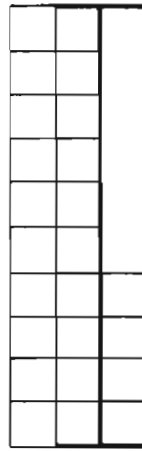

+

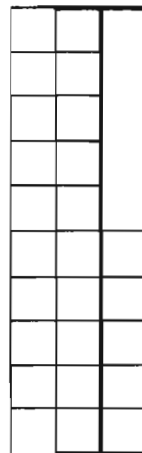

$$\begin{array}{r} \textcircled{1} \quad 16 \\ \quad 24 \\ \hline + 25 \\ \hline 65 \end{array}$$

$$\begin{array}{r} 12 \\ \quad 7 \\ \hline + 10 \\ \hline 29 \end{array}$$

$$\textcircled{1} \begin{array}{r} 15 \\ \quad 2 \\ \hline + 33 \\ \hline 60 \end{array}$$

$$\textcircled{1} \begin{array}{r} 12 \\ \quad 8 \\ \hline + 14 \\ \hline 44 \end{array}$$

$$\textcircled{1} \begin{array}{r} 4 \\ \quad 0 \\ \hline + 18 \\ \hline 52 \end{array}$$



How do you feel?  
¿Cómo se siente?

Dear Parents,

The check-up test on the other side of this last letter in the B-level computation books shows the great development in computational skills that your child has now made! To add a series of three 2-digit numbers your child has had to compute lots of addition and "regrouping", as has been discussed in previous letters.

Please notice that the representational sketches are still available on the page and still serve as most important reminders of what all that mathematical shorthand refers to. Even for the child who does not feel the need to use the pictures for the actual problem-solving, they serve as a valuable way to "self-check" the answer arrived at - just count (using the shortcut of "counting-on" from 10's, of course!) and see if you come up with the same number. Tensticks and beans can also be used as a self-check device. And again we encourage you to suggest to your child to use those "manipulative" devices whenever frustration or serious hesitation is occurring.

We can't repeat often enough that your child's attitude about math and about himself or herself as a competent learner are of the most vital importance. When a child feels good about numbers, confident about using them, comfortable talking about them, then that child will do well in mathematics - in the everyday use of numbers and on progress tests.

Your careful support and encouragement in helping us deal with numbers in a "friendly" way is greatly appreciated. We hope you have been able to detect the growth in the understanding of mathematical relationships that has been happening and will continue to happen for your child - with lots more fun and exciting discoveries along the way!

Sincerely,

2,174

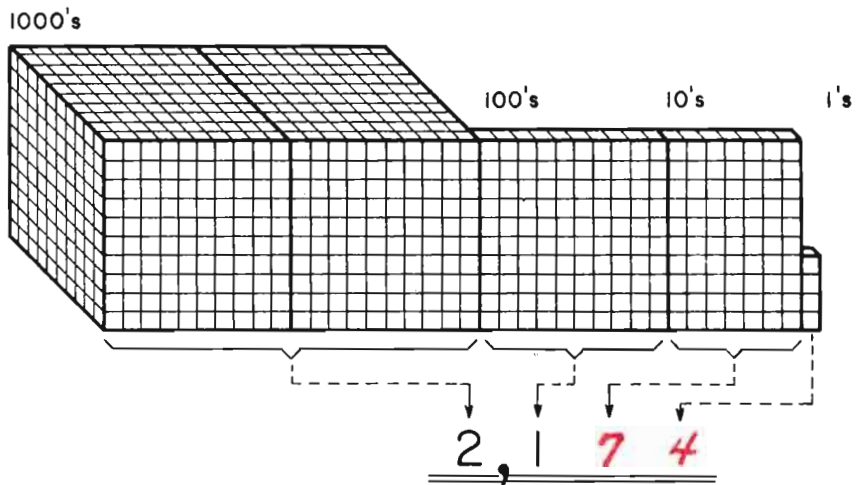

1,245

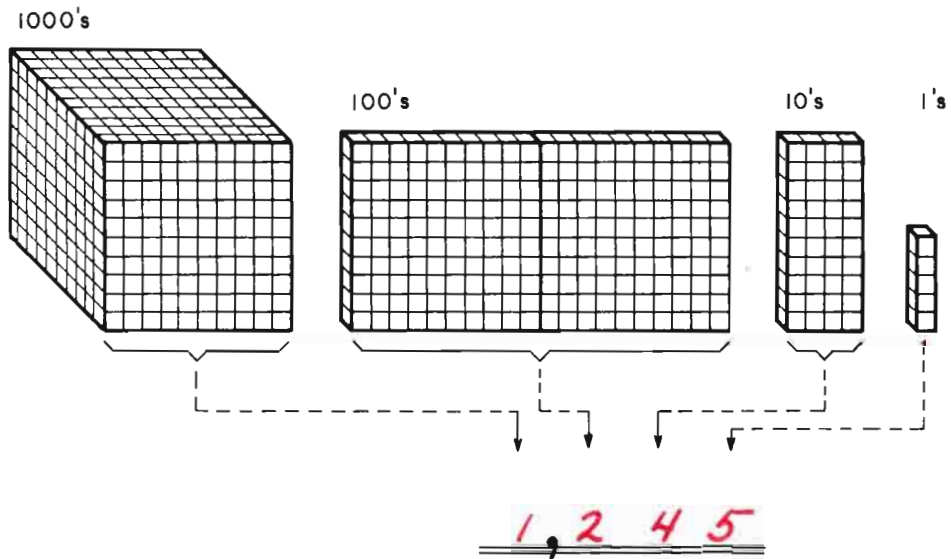

1,103

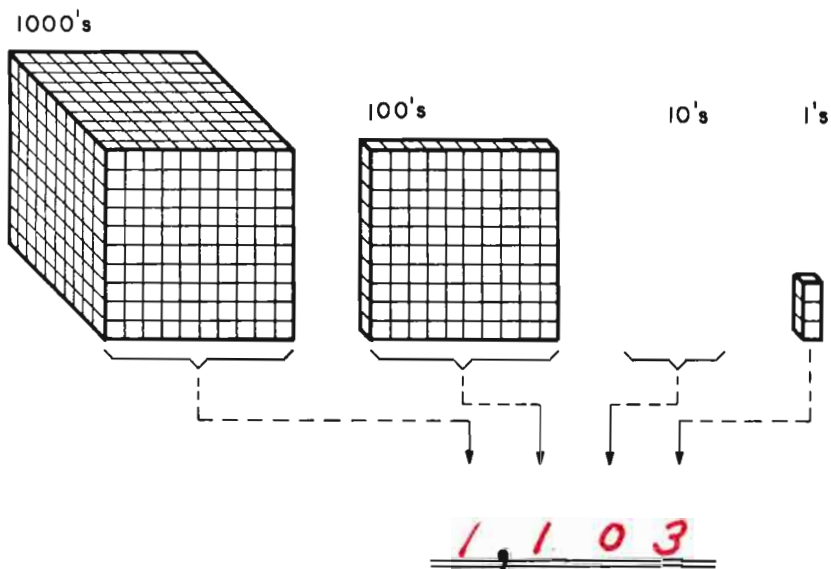

A. 2,153

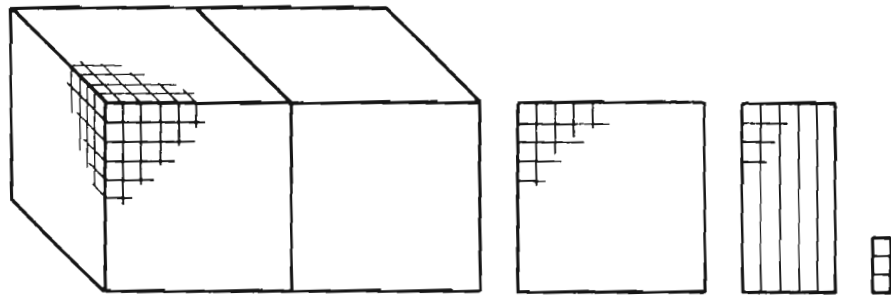

1000's    100's    10's    1's

A. 2,153

B. \_\_\_\_\_

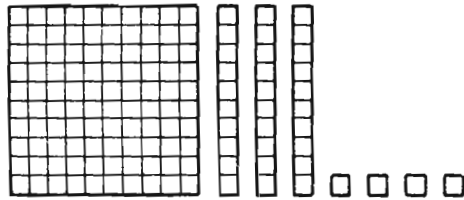

B. 134

C. 142

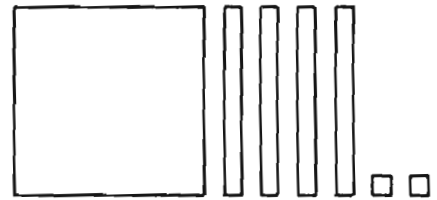

C. 142

D. \_\_\_\_\_

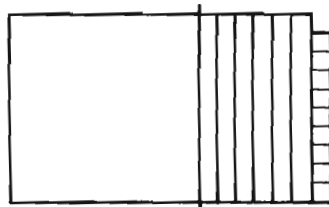

D. 169

E. 250

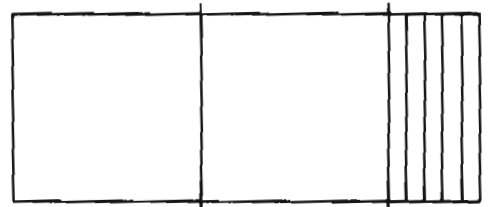

E. 250

F. 325

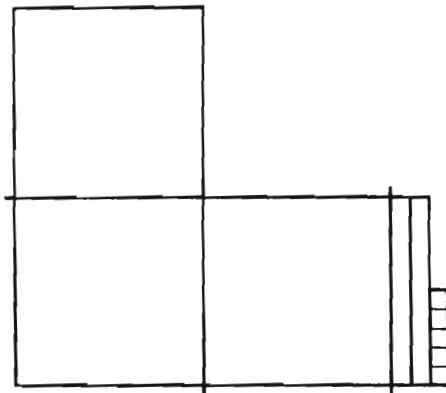

F. 325

G. \_\_\_\_\_

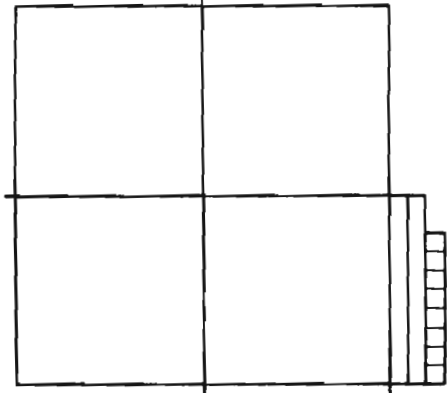

G. 428

H. 1,034

I.         

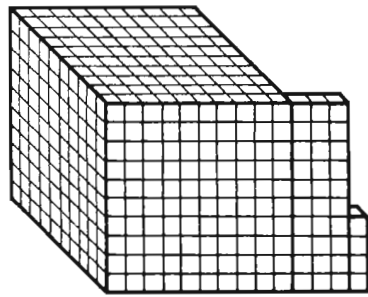

H. 1,034

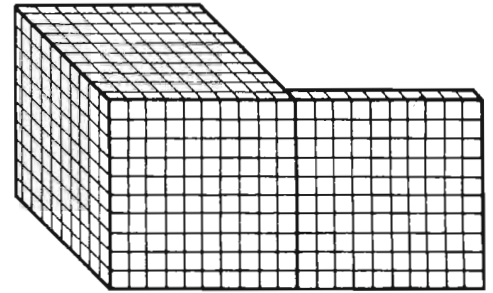

I. 1,100

J.         

K. 1,040

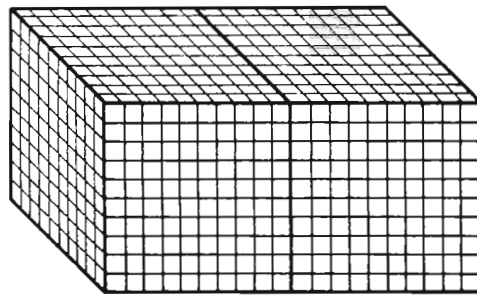

J. 2,000

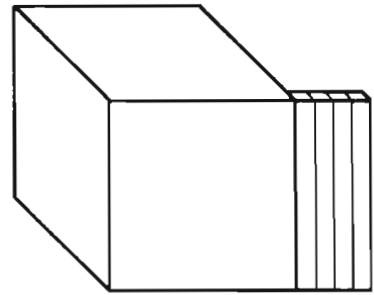

K. 1,040

L. 113

M.         

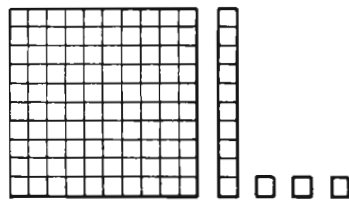

L. 113

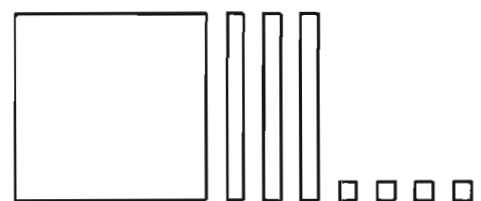

M. 134

N.         

O. 165

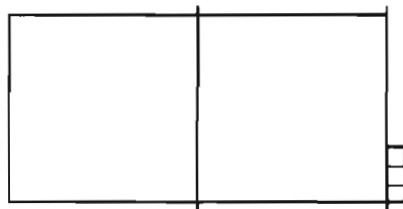

N. 203

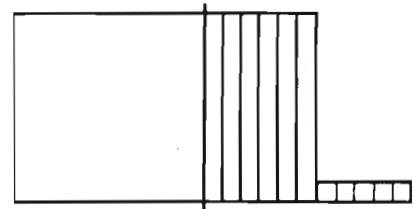

O. 165

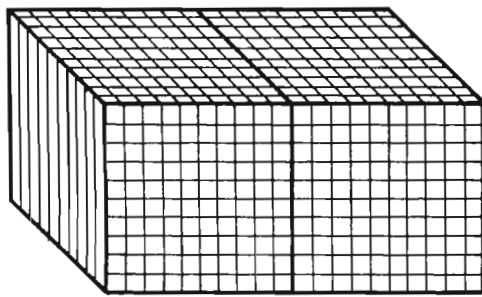
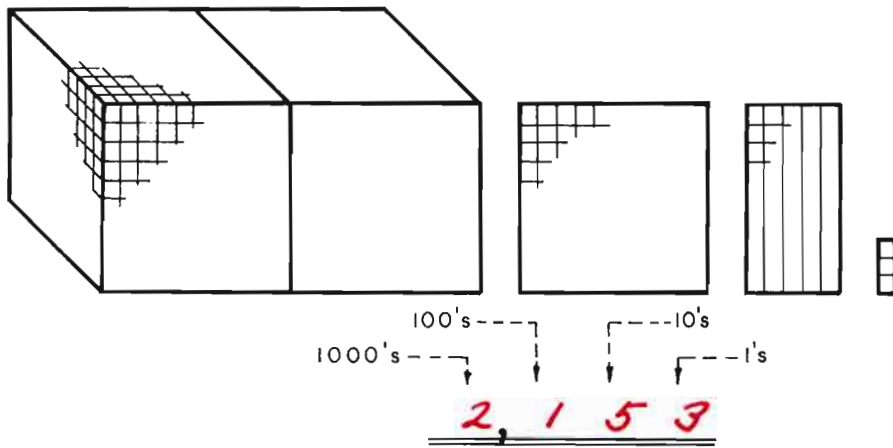

2,000

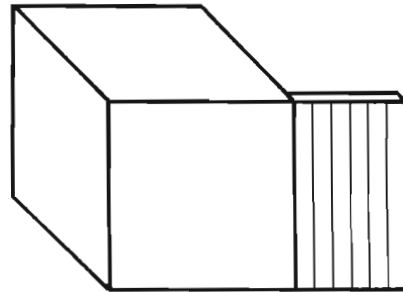

1,060

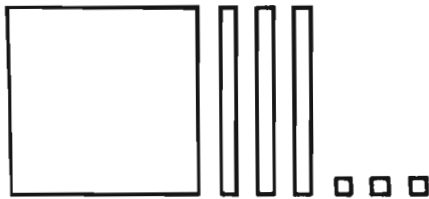

133

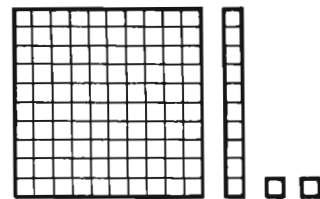

112

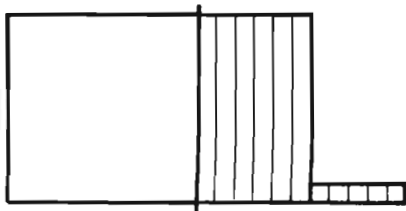

165

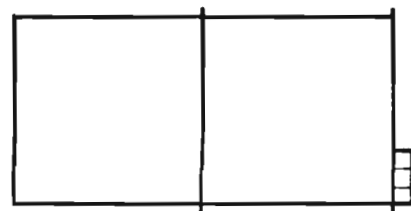

203



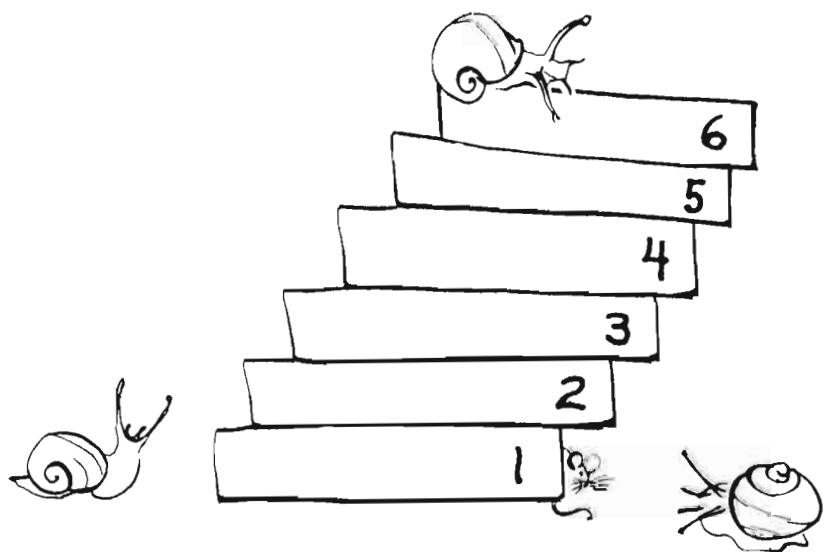



*this book  
belongs to* \_\_\_\_\_

*este libro  
es de* \_\_\_\_\_