

# Individualized Computation

$e_1$





Cover Art  
The Open Intermediate class of Patricia Faul and  
Howard McCombs at R.H. Down School

Art Staff  
LORENZO ANDRE

Editor and General Manager  
ROBERT BECK

Art and Production Manager  
LIESELOTTE ESSER

© 1974, CURRICULUM DEVELOPMENT ASSOCIATES, INC.  
787 Foam Street  
Monterey, CA 93940

Suite 414, 1211 Conn. Ave., NW  
Washington, DC 20036





PUZZLES AND PROBLEMS

ROMBECABEZAS y PROBLEMAS

Chain Reactions

Reacción en Cadena

|    |    |    |    |    |    |    |    |    |    |
|----|----|----|----|----|----|----|----|----|----|
| 5  | +3 | -4 | +6 | +9 | +2 | -3 | -9 | +1 | 10 |
| 3  | +3 | +3 | +3 | +3 | +3 | +3 | +3 | +3 | 27 |
| 30 | -3 | -3 | -3 | -3 | -3 | -3 | -3 | -3 | 6  |
| 6  | +7 | -8 | +9 | -7 | +8 | -9 | +8 | -8 | 6  |
| 1  | +2 | +3 | +4 | +5 | +6 | +7 | +8 | +9 | 45 |

Domino Puzzles .....

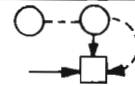

Rompecabezas de Dóminos

$5 + 6 = \underline{\quad}$

$8 + 8 = \underline{\quad}$

$+ 10 = \underline{\quad}$

Loop Arithmetic

Aritmética de Lazo

Sumar **Adding**  
 y **and**  
 Restar **Subtracting**  
 (7+2)

7  $\frac{9}{5}$  2  
 (7-2)

5 --- 3

6 --- 4

□  $\frac{6}{2}$  ○

□  $\frac{13}{7}$  ○

□  $\frac{15}{3}$  ○

**Multiplying** **Multiplicar**  
**and** **y**  
**Dividing** **Dividir**

(6 × 3)

6  $\frac{18}{2}$  3  
 (6 ÷ 3)

8 --- 2

4 --- 2

□  $\frac{12}{3}$  ○

□  $\frac{20}{5}$  ○

□  $\frac{27}{3}$  ○

**Multiplying and Adding**

..... using smallest numbers

|   |  |
|---|--|
| $\begin{array}{ c c } \hline 3 & 2 \\ \hline 2 & 1 \\ \hline \end{array} + 2 = \underline{\underline{8}}$ | $\begin{array}{ c c } \hline 3 & 3 \\ \hline 4 & \\ \hline \end{array} = \underline{\underline{13}}$ |
| $\begin{array}{ c c } \hline 3 & \\ \hline 4 & \\ \hline \end{array} = \underline{\underline{11}}$        | $\begin{array}{ c c } \hline 4 & \\ \hline 5 & \\ \hline \end{array} = \underline{\underline{17}}$   |

**Multiplicar y Sumar**

..... usando los números más pequeños

|  |  |
|--|--|
| $\begin{array}{ c c } \hline 2 & \\ \hline 5 & \\ \hline \end{array} = \underline{\underline{11}}$ | $\begin{array}{ c c } \hline 3 & \\ \hline 7 & \\ \hline \end{array} = \underline{\underline{20}}$ |
| $\begin{array}{ c c } \hline 2 & \\ \hline 9 & \\ \hline \end{array} = \underline{\underline{24}}$ | $\begin{array}{ c c } \hline 5 & \\ \hline 8 & \\ \hline \end{array} = \underline{\underline{34}}$ |

**TWO-WAY Chain Reactions**

**Reacción en cadena en DOS MANERAS**

Down and to the right

5  $\xrightarrow{(+4)}$  □  $\xrightarrow{(-3)}$  □

$\downarrow (-1)$        $\downarrow (+3)$        $\downarrow (+7)$

□  $\xrightarrow{(+8)}$  □  $\xrightarrow{(+1)}$  □

$\downarrow (+20)$        $\downarrow (+10)$        $\downarrow (+7)$

□  $\xrightarrow{(-2)}$  □  $\xrightarrow{(-2)}$  20

Abajo y a la derecha

8  $\xrightarrow{(-4)}$  □  $\xrightarrow{(-3)}$  □

$\downarrow (+3)$        $\downarrow (+11)$        $\downarrow (\quad)$

□  $\xrightarrow{(+4)}$  □  $\xrightarrow{(\quad)}$  □

$\downarrow (\quad)$        $\downarrow (\quad)$        $\downarrow (+2)$

20  $\xrightarrow{(\quad)}$  10  $\xrightarrow{(\quad)}$  8

"HOW MANY?"

"¿CUANTOS?"

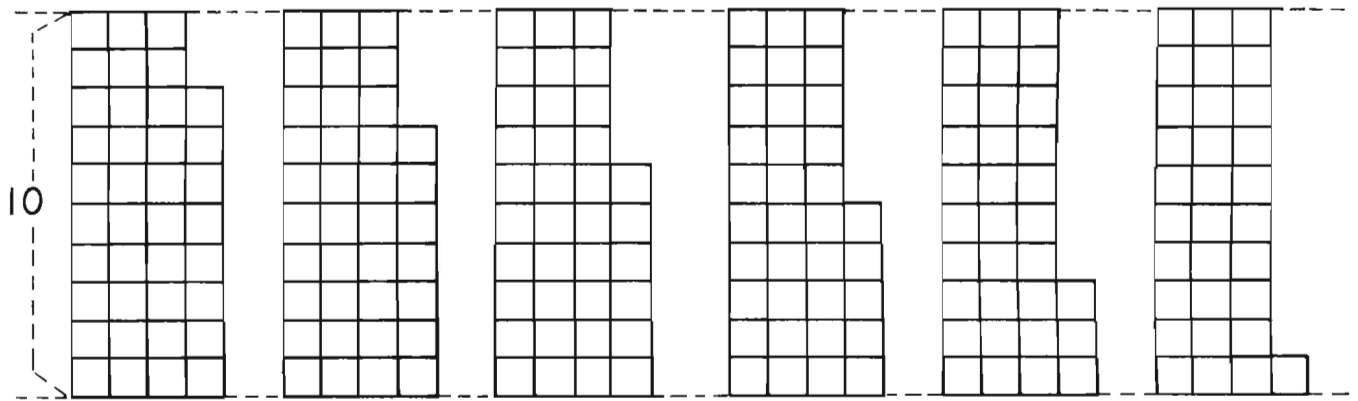

A ..... B ..... C ..... D ..... ..... E .....

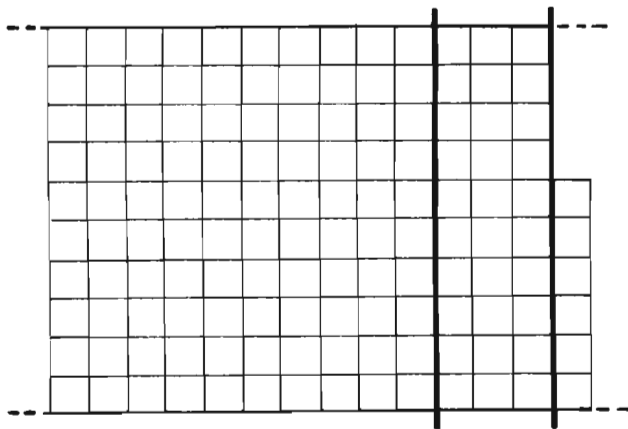

F .....

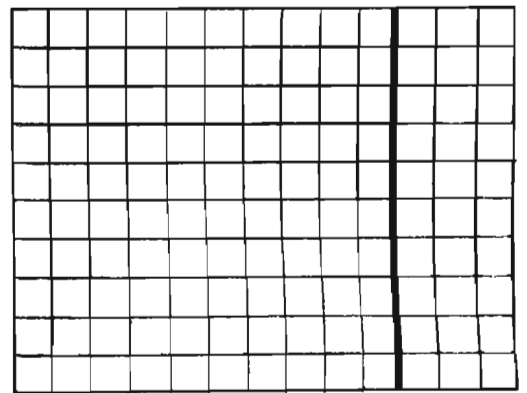

G .....

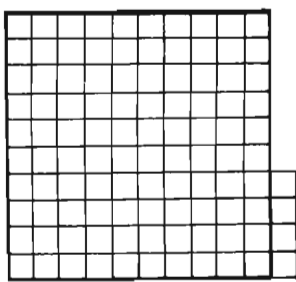

H .....

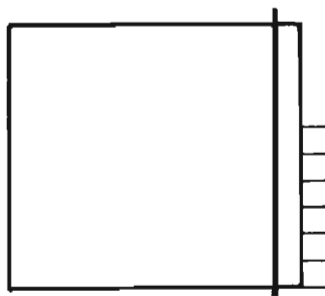

I .....

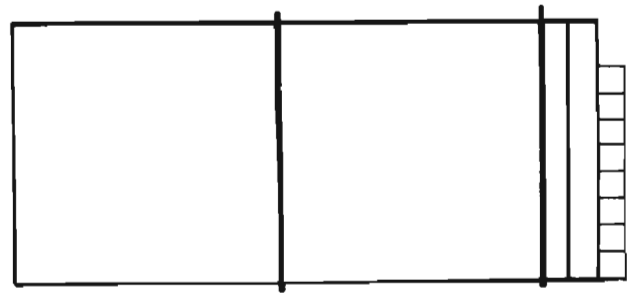

A .....

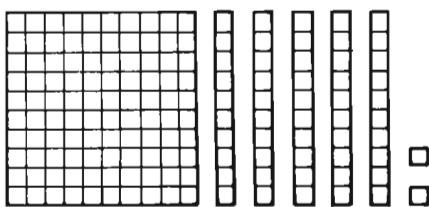

B .....

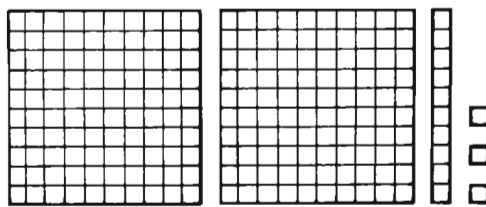

.....

|   | A   | B   | C   | D   |
|---|-----|-----|-----|-----|
| E | 228 | 37  | 31  | 282 |
| F | 22  | 136 | 45  | 35  |
| G | 38  | 47  | 130 | 138 |
| H | 104 | 26  | 36  | 140 |
| I | 206 | 152 | 72  | 116 |

"HOW MANY?" . . .

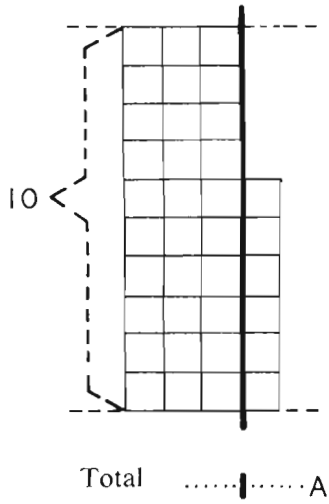

$$\begin{array}{r} 36 \\ - 6 \\ \hline \end{array}$$

\_\_\_\_\_ B

$$\begin{array}{r} 36 \\ + 14 \\ \hline \end{array}$$

\_\_\_\_\_ D

$$\begin{array}{r} 29 \\ + 7 \\ \hline \end{array}$$

\_\_\_\_\_

$$\begin{array}{r} 36 \\ + 4 \\ \hline \end{array}$$

\_\_\_\_\_ C

$$\begin{array}{r} 14 \\ + 36 \\ \hline \end{array}$$

\_\_\_\_\_ E

$$\begin{array}{r} 19 \\ + 17 \\ \hline \end{array}$$

\_\_\_\_\_ G

$$\begin{array}{r} 36 \\ + 10 \\ \hline \end{array}$$

\_\_\_\_\_

$$\begin{array}{r} 46 \\ + 4 \\ \hline \end{array}$$

\_\_\_\_\_ F

$$\begin{array}{r} 27 \\ + 19 \\ \hline \end{array}$$

\_\_\_\_\_ H

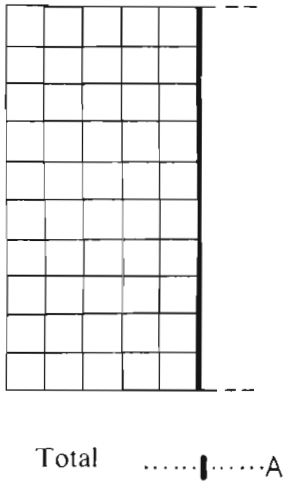

$$\begin{array}{r} 20 \\ + 30 \\ \hline \end{array}$$

\_\_\_\_\_ B

$$\begin{array}{r} 25 \\ + 25 \\ \hline \end{array}$$

\_\_\_\_\_ D

$$\begin{array}{r} 50 \\ + 50 \\ \hline \end{array}$$

\_\_\_\_\_ B

$$\begin{array}{r} 50 \\ - 10 \\ \hline \end{array}$$

\_\_\_\_\_ C

$$\begin{array}{r} 50 \\ - 25 \\ \hline \end{array}$$

\_\_\_\_\_ E

$$\begin{array}{r} 50 \\ - 6 \\ \hline \end{array}$$

\_\_\_\_\_

$$\begin{array}{r} 50 \\ + 20 \\ \hline \end{array}$$

\_\_\_\_\_

$$\begin{array}{r} 50 \\ + 25 \\ \hline \end{array}$$

\_\_\_\_\_ F

$$\begin{array}{r} 50 \\ - 16 \\ \hline \end{array}$$

\_\_\_\_\_ C

FENCING

7's

|   |   |   |   |
|---|---|---|---|
| 3 | 2 | 5 | 4 |
| 2 | 4 | 3 | 2 |
| 2 | 3 | 1 | 1 |
| 3 | 1 | 4 | 2 |

6's

|   |   |   |   |
|---|---|---|---|
| 3 | 3 | 2 | 4 |
| 1 | 4 | 1 | 2 |
| 2 | 2 | 5 | 1 |
| 5 | 1 | 4 | 2 |

CERCANDO

|   | A   | B   | C  |
|---|-----|-----|----|
| D | 50  | 100 | 34 |
| E | 25  | 30  | 50 |
| F | 36  | 50  | 75 |
| G | 100 | 36  | 40 |
| H | 46  | 50  | 40 |



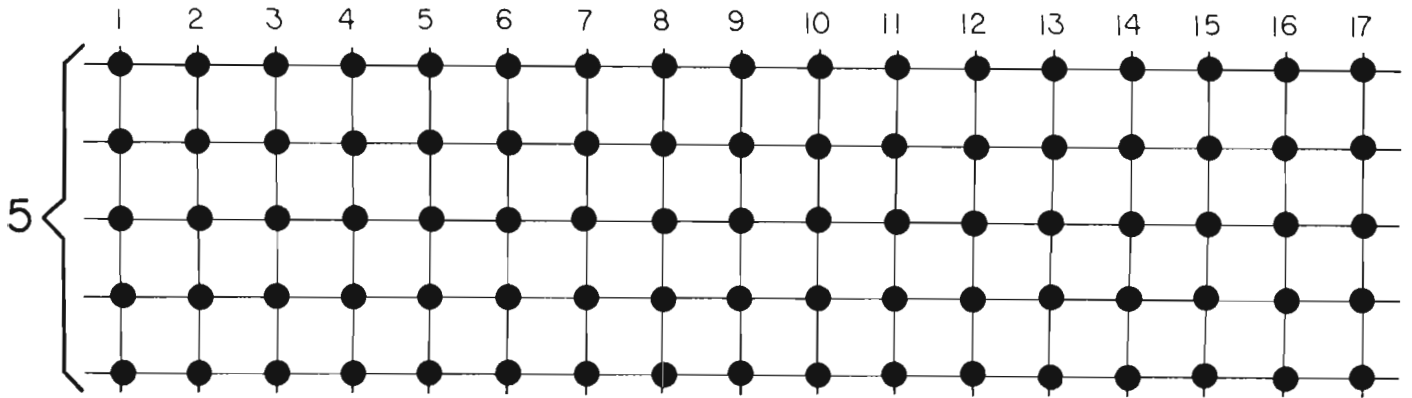

Please complete the tables

Favor de completar las tablas

|            |            |            |            |            |            |            |            |            |            |            |            |            |            |
|------------|------------|------------|------------|------------|------------|------------|------------|------------|------------|------------|------------|------------|------------|
| 0          | 1          | 2          | 3          | 4          | 5          | 6          | 7          | 8          | 9          | 10         | 11         | 12         | 13         |
| $\times 5$ | $\times 5$ | $\times 5$ | $\times 5$ | $\times 5$ | $\times 5$ | $\times 5$ | $\times 5$ | $\times 5$ | $\times 5$ | $\times 5$ | $\times 5$ | $\times 5$ | $\times 5$ |
| 0          | 5          |            |            |            |            |            |            |            |            |            |            |            |            |

A B C D E F G H I A B C D

|            |            |            |            |            |
|------------|------------|------------|------------|------------|
| 1          | 2          | 4          | 8          | 16         |
| $\times 5$ | $\times 5$ | $\times 5$ | $\times 5$ | $\times 5$ |
|            |            |            |            |            |

F

|            |            |            |            |
|------------|------------|------------|------------|
| 4          | 5          | 9          | 10         |
| $\times 5$ | $\times 5$ | $\times 5$ | $\times 5$ |
|            |            |            |            |

|            |            |            |
|------------|------------|------------|
| 3          | 6          | 9          |
| $\times 5$ | $\times 5$ | $\times 5$ |
|            |            |            |

|            |            |            |             |
|------------|------------|------------|-------------|
| 5          | 5          | 5          | 5           |
| $\times 3$ | $\times 4$ | $\times 7$ | $\times 11$ |
|            |            |            |             |

|             |            |            |            |
|-------------|------------|------------|------------|
| 5           | 5          | 5          | 5          |
| $\times 10$ | $\times 9$ | $\times 8$ | $\times 7$ |
|             |            |            |            |

|            |            |            |            |
|------------|------------|------------|------------|
| 5          | 5          | 5          | 5          |
| $\times 2$ | $\times 3$ | $\times 5$ | $\times 8$ |
|            |            |            |            |

|            |            |            |            |            |            |            |            |            |            |            |            |            |            |
|------------|------------|------------|------------|------------|------------|------------|------------|------------|------------|------------|------------|------------|------------|
| 2          | 5          | 5          | 5          | 10         | 11         | 5          | 5          | 12         | 13         | 5          | 5          | 6          | 9          |
| $\times 5$ | $\times 5$ | $\times 6$ | $\times 1$ | $\times 5$ | $\times 5$ | $\times 4$ | $\times 7$ | $\times 5$ | $\times 5$ | $\times 3$ | $\times 8$ | $\times 5$ | $\times 5$ |
|            |            |            |            |            |            |            |            |            |            |            |            |            |            |

Please extend the patterns as indicated

Favor de extender las muestras

2 . 4 . 6 . 8 . . . . . 20 .  
B

1 . 3 . 5 . 7 . . . . . 19 .  
C

3 . 7 . 11 . 15 . . . . . 39 .  
E

27 . 24 . 21 . 18 . . . . . 0 .

1 . 1 . 2 . 3 . 5 . 8 . . . . . 55 .

|   |    |    |    |    |
|---|----|----|----|----|
|   | A  | B  | C  | D  |
| E | 20 | 10 | 19 | 15 |
| F | 80 | 50 | 25 | 60 |
| G | 45 | 5  | 9  | 30 |
| H | 0  | 35 | 55 | 13 |
| I | 40 | 13 | 10 | 35 |

$\frac{1}{4}$  of 16 =      A  
 $\frac{2}{4}$  of 16 =      F  
 $\frac{3}{4}$  of 16 =      B  
 $\frac{1}{2}$  x 16 =      D

$\frac{1}{3}$  of 12 =      C  
 $\frac{2}{3}$  of 12 =      D  
 $\frac{3}{3}$  x 12 =      E  
 $\frac{1}{2}$  x 12 =      F

$\frac{1}{5}$  of      =      H  
 $\frac{2}{5}$  x      =      A  
 $\frac{3}{5}$  x      =      J  
 $\frac{4}{5}$  x      =      C

$\frac{1}{4}$  x      =      E  
 $\frac{3}{4}$  x      =      G  
 $\frac{2}{4}$  x      =      F  
 $\frac{1}{2}$  x      =      F

Please loop "Neighbors"  
 whose sum is given

Favor de poner un lazo  
 a los números "Vecinos"

|                          |                          |                          |                          |                          |                          |             |
|--------------------------|--------------------------|--------------------------|--------------------------|--------------------------|--------------------------|-------------|
| 2                        | 2                        | 2                        | 2                        | 2                        | 2                        | 2           |
| 5                        | 5                        | 5                        | 5                        | 5                        | 5                        | 5           |
| 1                        | 1                        | 1                        | 1                        | 1                        | 1                        | 1           |
| 6                        | 6                        | 6                        | 6                        | 6                        | 6                        | 6           |
| 4                        | 4                        | 4                        | 4                        | 4                        | 4                        | 4           |
| 3                        | 3                        | 3                        | 3                        | 3                        | 3                        | 3           |
| <u>    </u> <sup>A</sup> | <u>    </u> <sup>B</sup> | <u>    </u> <sup>C</sup> | <u>    </u> <sup>D</sup> | <u>    </u> <sup>G</sup> | <u>    </u> <sup>A</sup> | <u>    </u> |
| 10                       | 11                       | 13                       | 16                       | 18                       | 19                       | 21          |

|   | A           | B        | C          | D          |
|---|-------------|----------|------------|------------|
| E | 6,4         | 12       | 6,4<br>3   | 5          |
| F | 4           | 8        | 10         | 6          |
| G | 25<br>1,64  | 20       | 25<br>1,64 | 15         |
| H | 5,16<br>4,3 | 1,6<br>4 | 4          | 20         |
| I | 8           | 4        | 25<br>1    | 5,1<br>6,4 |
| J | 20          | 10       | 16         | 8          |

"HOW MANY?"

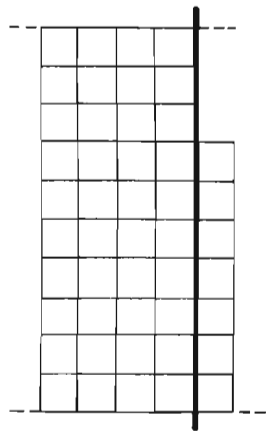

Total .....A

$$\begin{array}{r} 47 \\ - 7 \\ \hline \end{array}$$

\_\_\_\_\_

$$\begin{array}{r} 47 \\ - 17 \\ \hline \end{array}$$

\_\_\_\_\_D

$$\begin{array}{r} 30 \\ + 17 \\ \hline \end{array}$$

\_\_\_\_\_

"¿CUANTOS?"

$$\begin{array}{r} 47 \\ - 8 \\ \hline \end{array}$$

\_\_\_\_\_B

$$\begin{array}{r} 47 \\ - 18 \\ \hline \end{array}$$

\_\_\_\_\_E

$$\begin{array}{r} 29 \\ + 18 \\ \hline \end{array}$$

\_\_\_\_\_G

$$\begin{array}{r} 50 \\ - 3 \\ \hline \end{array}$$

\_\_\_\_\_C

$$\begin{array}{r} 47 \\ - 28 \\ \hline \end{array}$$

\_\_\_\_\_F

$$\begin{array}{r} 19 \\ + 28 \\ \hline \end{array}$$

\_\_\_\_\_H

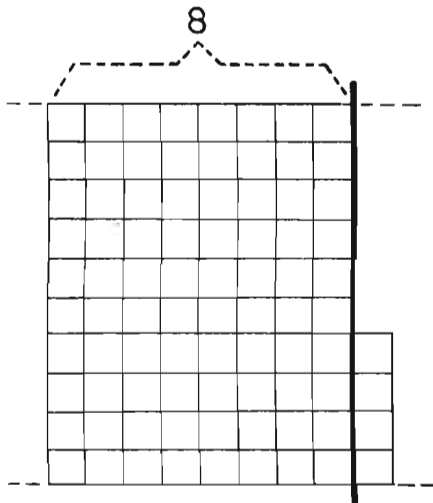

Total .....A

$$\begin{array}{r} 90 \\ - 6 \\ \hline \end{array}$$

\_\_\_\_\_B

$$\begin{array}{r} 84 \\ - 14 \\ \hline \end{array}$$

\_\_\_\_\_

$$\begin{array}{r} 84 \\ + 6 \\ \hline \end{array}$$

\_\_\_\_\_

$$\begin{array}{r} 84 \\ - 4 \\ \hline \end{array}$$

\_\_\_\_\_

$$\begin{array}{r} 84 \\ - 16 \\ \hline \end{array}$$

\_\_\_\_\_E

$$\begin{array}{r} 84 \\ + 16 \\ \hline \end{array}$$

\_\_\_\_\_

$$\begin{array}{r} 84 \\ - 6 \\ \hline \end{array}$$

\_\_\_\_\_D

$$\begin{array}{r} 84 \\ - 80 \\ \hline \end{array}$$

\_\_\_\_\_

$$\begin{array}{r} 100 \\ - 16 \\ \hline \end{array}$$

\_\_\_\_\_

Please use the smallest whole numbers you can in the boxes

Favor de poner en cada cuadro el número entero más pequeño que usted pueda.

$$\begin{array}{|c|c|c|c|} \hline 9 & 3 & 1 & \\ \hline 2 & 0 & 2 & 20 \\ \hline \end{array}$$

Yes

$$\begin{array}{|c|c|c|c|} \hline 9 & 3 & 1 & \\ \hline 1 & 3 & 8 & 20 \\ \hline \end{array}$$

No

$$\begin{array}{|c|c|c|c|} \hline 9 & 3 & 1 & \\ \hline 0 & 2 & 2 & 8 \\ \hline \end{array}$$

C

$$\begin{array}{|c|c|c|c|} \hline 9 & 3 & 1 & \\ \hline & & & 13 \\ \hline \end{array}$$

$$\begin{array}{|c|c|c|c|} \hline 9 & 3 & 1 & \\ \hline & & & 18 \\ \hline \end{array}$$

D

$$\begin{array}{|c|c|c|c|} \hline 9 & 3 & 1 & \\ \hline & & & 17 \\ \hline \end{array}$$

F

$$\begin{array}{|c|c|c|c|} \hline 9 & 3 & 1 & \\ \hline & & & 21 \\ \hline \end{array}$$

G

$$\begin{array}{|c|c|c|c|} \hline 9 & 3 & 1 & \\ \hline & & & 26 \\ \hline \end{array}$$

H

|   | A     | B     | C     |
|---|-------|-------|-------|
| D | 30    | 84    | 78    |
| E | 68    | 39    | 29    |
| F | 1,2,2 | 19    | 47    |
| G | 47    | 2,1,0 | 0,2,2 |
| H | 84    | 47    | 22,2  |

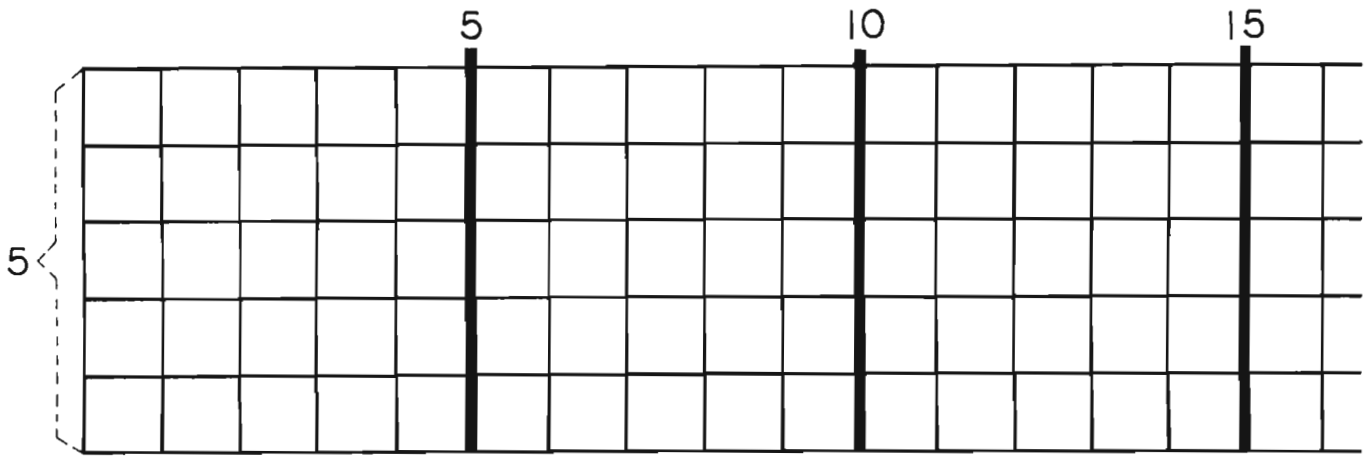

|                    |                     |                        |                        |                        |                        |                        |                        |                        |
|--------------------|---------------------|------------------------|------------------------|------------------------|------------------------|------------------------|------------------------|------------------------|
| $5 \overline{) 5}$ | $5 \overline{) 10}$ | $5 \overline{) \quad}$ | $5 \overline{) \quad}$ | $5 \overline{) \quad}$ | $5 \overline{) \quad}$ | $5 \overline{) \quad}$ | $5 \overline{) \quad}$ | $5 \overline{) \quad}$ |
| A                  | B                   | C                      | D                      | E                      | F                      | G                      |                        |                        |

|                     |                     |                     |                     |
|---------------------|---------------------|---------------------|---------------------|
| $5 \overline{) 10}$ | $5 \overline{) 20}$ | $5 \overline{) 40}$ | $5 \overline{) 60}$ |
| H                   |                     |                     |                     |

|                     |                     |                     |                     |
|---------------------|---------------------|---------------------|---------------------|
| $5 \overline{) 20}$ | $5 \overline{) 15}$ | $5 \overline{) 35}$ | $5 \overline{) 50}$ |
|---------------------|---------------------|---------------------|---------------------|

|                     |                     |                     |                      |
|---------------------|---------------------|---------------------|----------------------|
| $5 \overline{) 50}$ | $5 \overline{) 25}$ | $5 \overline{) 75}$ | $5 \overline{) 100}$ |
| I                   | A                   |                     |                      |

|                     |                     |                     |                     |
|---------------------|---------------------|---------------------|---------------------|
| $5 \overline{) 25}$ | $5 \overline{) 20}$ | $5 \overline{) 15}$ | $5 \overline{) 10}$ |
|---------------------|---------------------|---------------------|---------------------|

|                     |                     |                     |                     |
|---------------------|---------------------|---------------------|---------------------|
| $5 \overline{) 45}$ | $5 \overline{) 40}$ | $5 \overline{) 35}$ | $5 \overline{) 30}$ |
|---------------------|---------------------|---------------------|---------------------|

|                    |                    |                    |                    |
|--------------------|--------------------|--------------------|--------------------|
| $1 \overline{) 5}$ | $2 \overline{) 5}$ | $4 \overline{) 5}$ | $8 \overline{) 5}$ |
| B                  | E                  | C                  |                    |

|                     |                     |                     |                    |                     |                     |                     |                     |                     |
|---------------------|---------------------|---------------------|--------------------|---------------------|---------------------|---------------------|---------------------|---------------------|
| $5 \overline{) 10}$ | $5 \overline{) 30}$ | $5 \overline{) 20}$ | $5 \overline{) 5}$ | $5 \overline{) 35}$ | $5 \overline{) 25}$ | $5 \overline{) 40}$ | $5 \overline{) 15}$ | $5 \overline{) 45}$ |
| H                   |                     |                     |                    |                     |                     |                     |                     |                     |

|  |  |  |  |  |
|--|--|--|--|--|
| $\begin{array}{r} 32 \\ 32 \\ +32 \\ \hline \end{array}$ | $\begin{array}{r} 43 \\ 43 \\ +43 \\ \hline \end{array}$ | $\begin{array}{r} 34 \\ 34 \\ +34 \\ \hline \end{array}$ | $\begin{array}{r} 25 \\ 25 \\ +25 \\ \hline \end{array}$ | $\begin{array}{r} 52 \\ 52 \\ +52 \\ \hline \end{array}$ |
| A  | B  | C  | D  |  |

|  |  |  |  |  |
|--|--|--|--|--|
| $\begin{array}{r} 55 \\ 55 \\ +55 \\ \hline \end{array}$ | $\begin{array}{r} 66 \\ 66 \\ +66 \\ \hline \end{array}$ | $\begin{array}{r} 77 \\ 77 \\ +77 \\ \hline \end{array}$ | $\begin{array}{r} 88 \\ 88 \\ +88 \\ \hline \end{array}$ | $\begin{array}{r} 99 \\ 99 \\ +99 \\ \hline \end{array}$ |
| F  | G  | G  |  | H  |

|   | A   | B   | C   | D   |
|---|-----|-----|-----|-----|
| E | 20  | 35  | 102 | 30  |
| F | 15  | 5   | 40  | 165 |
| G | 45  | 231 | 25  | 198 |
| H | 297 | 20  | 8   | 12  |
| I | 96  | 129 | 15  | 75  |

Here is one of the many methods that lead to correct answers.

Some call it "regrouping"; others call it "carrying and borrowing". If you already have a good method, please use it.

Este es una de las muchas maneras que le lleva a las respuestas correctas.

Algunos lo llaman "re grupar" otros lo llaman "llevar y pedir prestado". Si usted ya tiene un buen método favor de usarlo.

| Addition  |  | Subtraction   |   | Multiplication   |   | Division                      |                      |
|---|--|---|---|--|---|-------------------------------|----------------------|
| $\begin{array}{r} 26 \\ +26 \\ \hline 52 \end{array}$ | $\begin{array}{r} 26 \\ +26 \\ \hline \end{array}$ | $\begin{array}{r} 4 \cancel{5} 2 \\ -26 \\ \hline 26 \end{array}$ | $\begin{array}{r} 52 \\ -26 \\ \hline \end{array}$  | $\begin{array}{r} 26 \\ \times 2 \\ \hline 52 \end{array}$ | $\begin{array}{r} 26 \\ \times 2 \\ \hline \end{array}$ | $2 \overline{) \cancel{5} 2}$ | $2 \overline{) 52}$  |
| $\begin{array}{r} 57 \\ +57 \\ \hline 4 \end{array}$  | $\begin{array}{r} 57 \\ +57 \\ \hline \end{array}$ | $\begin{array}{r} 0 \cancel{1} 4 \\ -57 \\ \hline 5 \end{array}$  | $\begin{array}{r} 114 \\ -57 \\ \hline \end{array}$ | $\begin{array}{r} 57 \\ \times 2 \\ \hline 4 \end{array}$  | $\begin{array}{r} 57 \\ \times 2 \\ \hline \end{array}$ | $2 \overline{) \cancel{1} 4}$ | $2 \overline{) 114}$ |
| $\begin{array}{r} 30 \\ +48 \\ \hline 78 \end{array}$ | $\begin{array}{r} 35 \\ +48 \\ \hline \end{array}$ | $\begin{array}{r} 83 \\ -40 \\ \hline 4 \end{array}$              | $\begin{array}{r} 83 \\ -48 \\ \hline \end{array}$  | $\begin{array}{r} 13 \\ \times 3 \\ \hline 9 \end{array}$  | $\begin{array}{r} 18 \\ \times 3 \\ \hline \end{array}$ | $3 \overline{) 30}$           | $3 \overline{) 54}$  |
| $\begin{array}{r} 95 \\ +30 \\ \hline \end{array}$    | $\begin{array}{r} 95 \\ +36 \\ \hline \end{array}$ | $\begin{array}{r} 131 \\ -30 \\ \hline \end{array}$               | $\begin{array}{r} 131 \\ -36 \\ \hline \end{array}$ | $\begin{array}{r} 20 \\ \times 5 \\ \hline \end{array}$    | $\begin{array}{r} 27 \\ \times 5 \\ \hline \end{array}$ | $5 \overline{) 120}$          | $5 \overline{) 135}$ |

"Regroup"?

¿"Regrupa"?

"YES" (Y) or "NO" (N)

| (Y) N  | Y (N)  | Y N   | Y N  | Y N  | Y N   | Y N                 | Y N                 |
|--|--|---|--|--|---|---------------------|---------------------|
| $\begin{array}{r} 31 \\ +19 \\ \hline \end{array}$ | $\begin{array}{r} 55 \\ -13 \\ \hline \end{array}$ | $\begin{array}{r} 21 \\ \times 4 \\ \hline \end{array}$ | $\begin{array}{r} 45 \\ +53 \\ \hline \end{array}$ | $\begin{array}{r} 45 \\ -18 \\ \hline \end{array}$ | $\begin{array}{r} 16 \\ \times 2 \\ \hline \end{array}$ | $3 \overline{) 63}$ | $2 \overline{) 32}$ |
| A  | B  | C   | D  | E  | F   | G                   | I                   |

|   | A   | B  | C   | D  | E  |
|---|-----|----|-----|----|----|
| F | Y   | 27 | 35  | Y  | Y  |
| G | 135 | N  | 114 | N  | 54 |
| H | 114 | 18 | N   | 41 | 83 |
| I | 28  | 19 | 131 | 57 | Y  |
| J | 0   | 57 | 84  | 9  | 95 |

M ... 5¢

T = 3

12 inches = 1 FOOT

| M  | TOTAL    |
|----|----------|
| 1  | 5¢       |
| 2  | ¢ A      |
| 4  | ¢        |
|    | 40¢ B    |
| 16 | ¢        |
|    | \$1.60 C |
|    | \$3.20 D |

| T | total |
|---|-------|
| 1 | 3     |
| 3 | 9     |
| 2 |       |
| 6 |       |
|   | 21 A  |
|   | 12 B  |
| 5 |       |

| FEET          | inches |
|---------------|--------|
| 1             | 12     |
| 2             |        |
|               | 36 C   |
| $\frac{1}{2}$ |        |
|               | D      |
| $\frac{1}{3}$ |        |
|               | E      |
| $\frac{1}{4}$ |        |
|               | F      |
| $\frac{1}{6}$ |        |
|               | A      |

C →  $\frac{1}{2}$

1 METER  
↓  
10 decimeters

16 GLASSES  
↘  
1 gallon

| C  | TOTAL |
|----|-------|
| 2  | 3     |
| 4  |       |
| 6  | B     |
| 10 | C     |
|    | 30 F  |
| 8  | D     |
|    | 24 E  |
|    | 18 F  |

| METERS         | decimeters |
|----------------|------------|
| 1              | 10         |
| 2              | F          |
| 3              |            |
|                | 90 B       |
| $\frac{1}{2}$  | B          |
| $\frac{1}{10}$ | D          |
| $\frac{3}{10}$ | E          |
|                | 50 B       |

| GALLON        | GLASSES |
|---------------|---------|
| 1             | 16      |
| $\frac{1}{2}$ | F       |
| $\frac{1}{4}$ | B       |
| $\frac{1}{8}$ | C       |

| A  | B | C  | D  | E  | F  |
|----|---|----|----|----|----|
| 7  | 9 | 3  | 64 | 3  | 12 |
| 21 | 8 | 15 | 12 | 4  | 8  |
| 10 | 5 | 2  | 6  | 9  | 3  |
| 2  | 4 | 32 | 1  | 16 | 20 |

**Addition**  
Sumar

$$\begin{array}{r} 43 \\ + 20 \\ \hline \end{array} \quad \begin{array}{r} 43 \\ + 7 \\ \hline \end{array}$$

$$\begin{array}{r} 43 \\ + 28 \\ \hline \end{array} \quad \begin{array}{r} 33 \\ + 9 \\ \hline \end{array}$$

$$\begin{array}{r} 53 \\ + 13 \\ \hline \end{array} \quad \begin{array}{r} 43 \\ + 43 \\ \hline \end{array}$$

**Subtraction**  
Restar

$$\begin{array}{r} 43 \\ - 13 \\ \hline \end{array} \quad \begin{array}{r} 43 \\ - 4 \\ \hline \end{array}$$

$$\begin{array}{r} 43 \\ - 14 \\ \hline \end{array} \quad \begin{array}{r} 73 \\ - 15 \\ \hline \end{array}$$

$$\begin{array}{r} 43 \\ - 18 \\ \hline \end{array} \quad \begin{array}{r} 53 \\ - 26 \\ \hline \end{array}$$

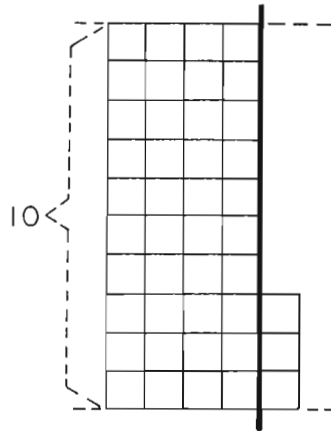

Total -----

|            |            |            |            |            |            |            |            |            |            |            |            |            |            |
|------------|------------|------------|------------|------------|------------|------------|------------|------------|------------|------------|------------|------------|------------|
| 0          | 1          | 2          | 3          | 4          | 5          | 6          | 7          | 8          | 9          | 10         | 11         | 12         | 13         |
| $\times 5$ | $\times 5$ | $\times 5$ | $\times 5$ | $\times 5$ | $\times 5$ | $\times 5$ | $\times 5$ | $\times 5$ | $\times 5$ | $\times 5$ | $\times 5$ | $\times 5$ | $\times 5$ |

|            |            |            |
|------------|------------|------------|
| 5          | 10         | 15         |
| $\times 5$ | $\times 5$ | $\times 5$ |

|            |            |            |
|------------|------------|------------|
| 4          | 8          | 16         |
| $\times 5$ | $\times 5$ | $\times 5$ |

|        |        |        |         |
|--------|--------|--------|---------|
| 5   35 | 5   70 | 5   45 | 5   90  |
| 5   25 | 5   50 | 5   75 | 5   100 |
| 5   40 | 5   80 | 5   55 | 5   110 |

|            |            |            |
|------------|------------|------------|
| 9          | 10         | 19         |
| $\times 5$ | $\times 5$ | $\times 5$ |

|            |            |            |
|------------|------------|------------|
| 7          | 14         | 28         |
| $\times 5$ | $\times 5$ | $\times 5$ |

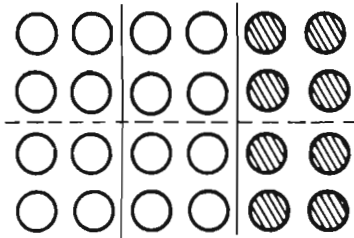

How do you feel?  
¿Cómo se siente?

Total

$$\frac{1}{3} \text{ of } 24 = \underline{\quad}$$

$$\frac{2}{3} \times 24 = \underline{\quad}$$

$$\frac{1}{2} \times 24 = \underline{\quad}$$

$$\frac{3}{3} \times 24 = \underline{\quad}$$

$$1 \text{ W} = 4 \text{ N}$$

$$1 \text{ DOZ} = 12 \text{ EGGS}$$

| W | N  |
|---|----|
| 1 | 4  |
| 3 |    |
|   | 24 |
| 9 |    |
|   | 20 |

| DOZ.          | EGGS |
|---------------|------|
| 1             |      |
| 3             | 36   |
| $\frac{1}{2}$ |      |
| $\frac{1}{3}$ |      |
| $\frac{1}{6}$ |      |

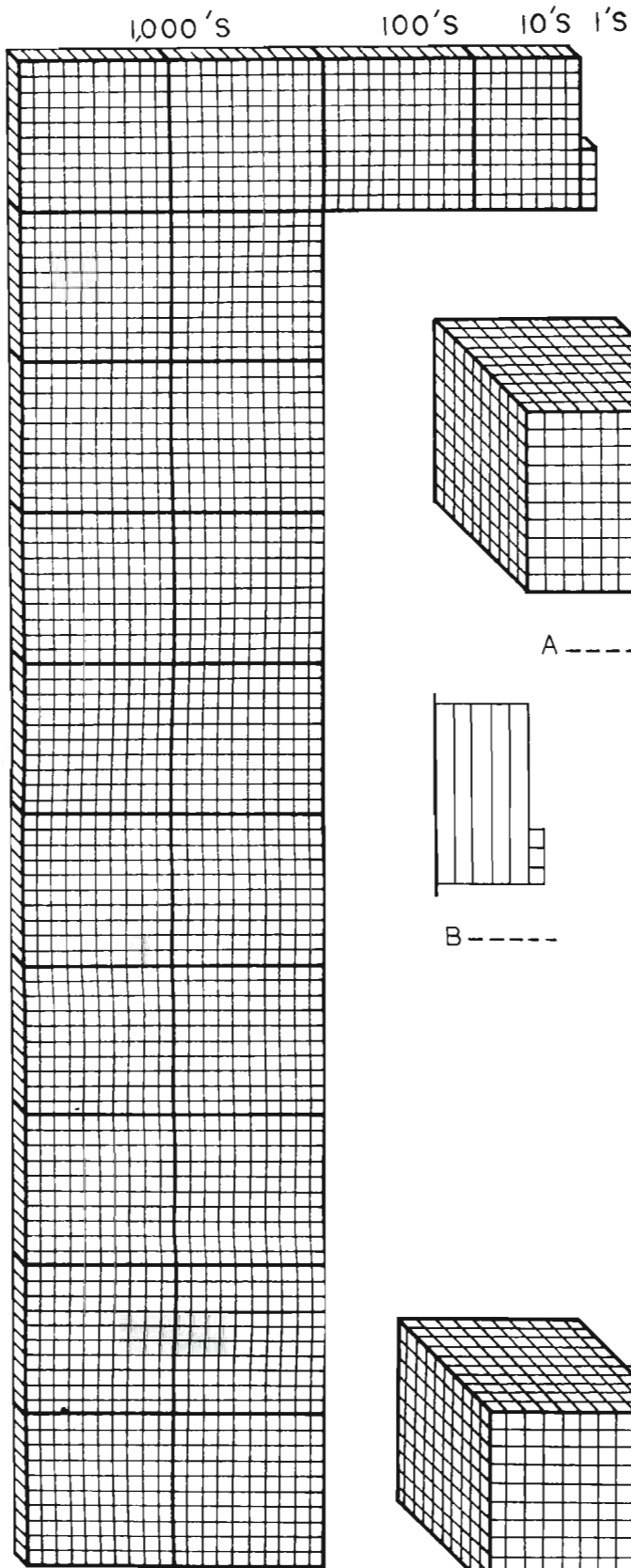

TWO thousand    DOS mil  
 ONE hundred    CIENTO  
 SEVEN ty        SETENTA  
 FOUR             CUATRO

2,174

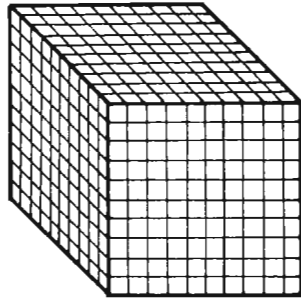

A -----

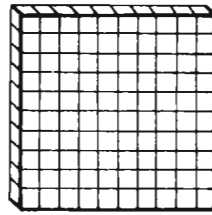

B -----



C ---



A ---



B -----

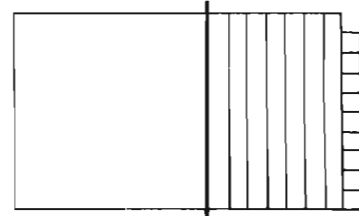

c 179

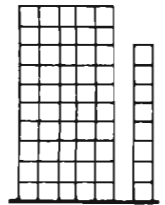

A -----

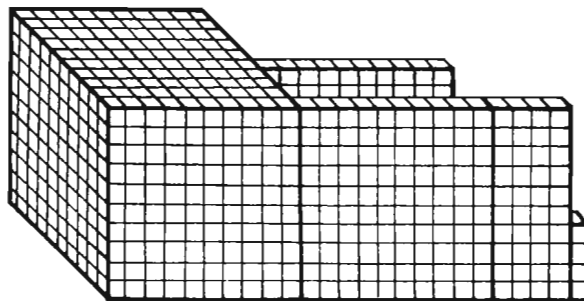

B -----

| A     | B     | C   |
|-------|-------|-----|
| 58    | 94    | 179 |
| 256   | 100   | 234 |
| 1     | 1,244 | 10  |
| 1,000 | 940   | 971 |
| 327   | 53    | 719 |



"HOW MANY?"

"¿CUANTOS?"

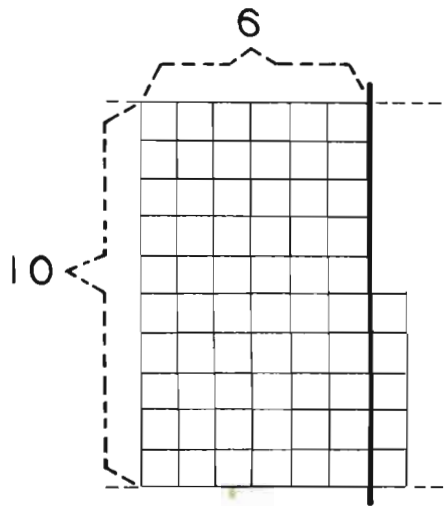

Total .....A

$$\begin{array}{r} 60 \\ + 5 \\ \hline \end{array}$$

.....E

$$\begin{array}{r} 65 \\ - 5 \\ \hline \end{array}$$

.....C

$$\begin{array}{r} 55 \\ + 5 \\ \hline \end{array}$$

.....H

$$\begin{array}{r} 60 \\ + 10 \\ \hline \end{array}$$

.....B

$$\begin{array}{r} 65 \\ - 6 \\ \hline \end{array}$$

.....A

$$\begin{array}{r} 55 \\ + 15 \\ \hline \end{array}$$

.....D

$$\begin{array}{r} 60 \\ + 15 \\ \hline \end{array}$$

.....G

$$\begin{array}{r} 65 \\ - 16 \\ \hline \end{array}$$

.....C

$$\begin{array}{r} 55 \\ + 35 \\ \hline \end{array}$$

.....H

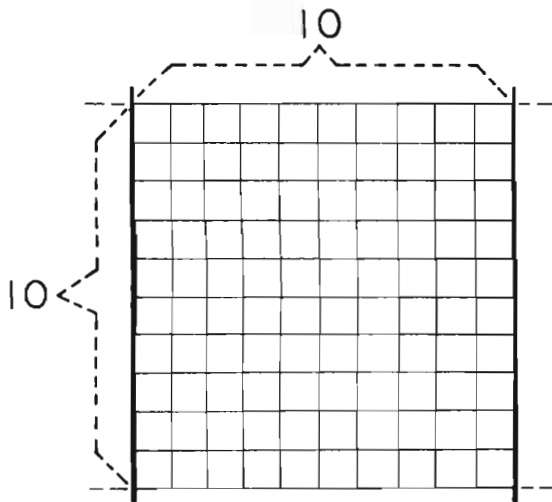

Total .....B

$$\begin{array}{r} 50 \\ + 50 \\ \hline \end{array}$$

.....F

$$\begin{array}{r} 100 \\ + 300 \\ \hline \end{array}$$

.....

$$\begin{array}{r} 100 \\ - 5 \\ \hline \end{array}$$

.....

$$\begin{array}{r} 100 \\ + 50 \\ \hline \end{array}$$

.....

$$\begin{array}{r} 150 \\ + 350 \\ \hline \end{array}$$

.....D

$$\begin{array}{r} 100 \\ - 10 \\ \hline \end{array}$$

.....A

$$\begin{array}{r} 150 \\ + 50 \\ \hline \end{array}$$

.....C

$$\begin{array}{r} 125 \\ + 375 \\ \hline \end{array}$$

.....A

$$\begin{array}{r} 100 \\ - 15 \\ \hline \end{array}$$

.....B

Chain Reactions

Reacción en Cadena

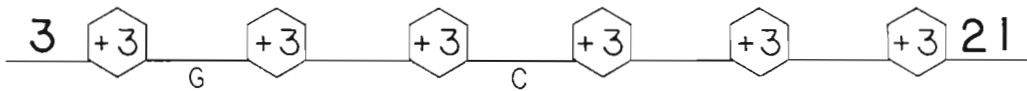

|   | A   | B   | C   |
|---|-----|-----|-----|
| D | 500 | 70  | 12  |
| E | 65  | 85  | 49  |
| F | 16  | 100 | 200 |
| G | 59  | 75  | 6   |
| H | 90  | 40  | 60  |

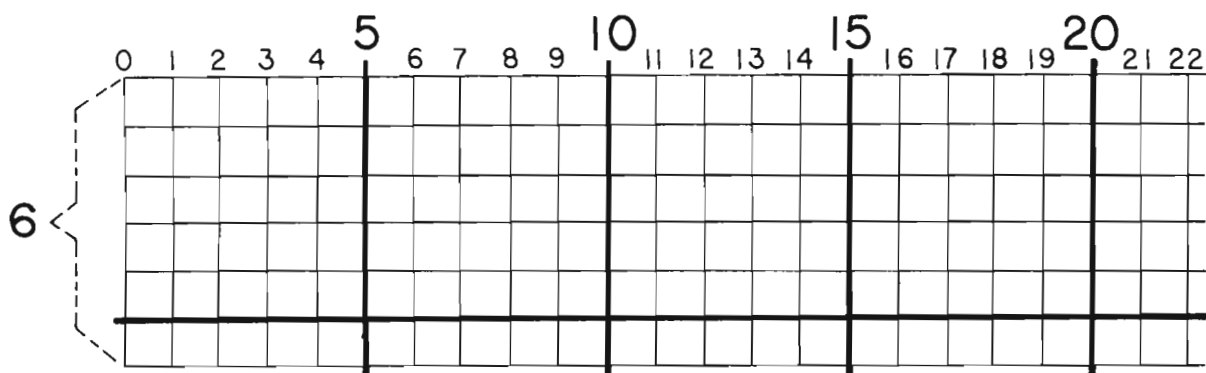

Please complete the tables

Favor de completar las tablas

|            |            |            |            |            |            |            |            |            |            |            |            |            |            |
|------------|------------|------------|------------|------------|------------|------------|------------|------------|------------|------------|------------|------------|------------|
| 0          | 1          | 2          | 3          | 4          | 5          | 6          | 7          | 8          | 9          | 10         | 11         | 12         | 13         |
| $\times 6$ | $\times 6$ | $\times 6$ | $\times 6$ | $\times 6$ | $\times 6$ | $\times 6$ | $\times 6$ | $\times 6$ | $\times 6$ | $\times 6$ | $\times 6$ | $\times 6$ | $\times 6$ |
| 0          | 6          |            |            |            |            |            |            |            |            |            |            |            |            |
| A          | B          | C          | D          | E          | F          | G          | H          | I          | A          | B          | C          |            |            |

|            |            |            |            |            |
|------------|------------|------------|------------|------------|
| 1          | 2          | 4          | 8          | 12         |
| $\times 6$ | $\times 6$ | $\times 6$ | $\times 6$ | $\times 6$ |
|            |            |            |            |            |

|            |            |            |            |
|------------|------------|------------|------------|
| 6          | 6          | 6          | 6          |
| $\times 2$ | $\times 5$ | $\times 7$ | $\times 8$ |
|            |            |            |            |

|            |            |            |
|------------|------------|------------|
| 3          | 6          | 9          |
| $\times 6$ | $\times 6$ | $\times 6$ |
|            |            |            |

|            |            |            |            |
|------------|------------|------------|------------|
| 4          | 6          | 10         | 16         |
| $\times 6$ | $\times 6$ | $\times 6$ | $\times 6$ |
|            |            |            |            |

G

|            |            |            |            |
|------------|------------|------------|------------|
| 6          | 6          | 6          | 6          |
| $\times 4$ | $\times 3$ | $\times 7$ | $\times 8$ |
|            |            |            |            |

|            |            |            |            |
|------------|------------|------------|------------|
| 6          | 8          | 14         | 15         |
| $\times 6$ | $\times 6$ | $\times 6$ | $\times 6$ |
|            |            |            |            |

H D

|            |            |            |            |            |            |            |            |            |            |            |            |            |            |
|------------|------------|------------|------------|------------|------------|------------|------------|------------|------------|------------|------------|------------|------------|
| 5          | 10         | 15         | 6          | 6          | 6          | 10         | 3          | 13         | 6          | 6          | 6          | 7          | 14         |
| $\times 6$ | $\times 6$ | $\times 6$ | $\times 4$ | $\times 5$ | $\times 9$ | $\times 6$ | $\times 6$ | $\times 6$ | $\times 7$ | $\times 8$ | $\times 9$ | $\times 6$ | $\times 6$ |
|            |            |            |            |            |            |            |            |            |            |            |            |            |            |

D D

Sums and Differences

Sumas y Diferencias

(10+7)  
 $\boxed{10} - \frac{17}{3} = \bigcirc 7$

$\boxed{9} - \dots = \bigcirc 4$

$\boxed{8} - \dots = \bigcirc 8$

(10-7)  
 $\boxed{\phantom{00}} - \frac{10}{2} = \bigcirc$

A  $\boxed{\phantom{00}} - \frac{10}{8} = \bigcirc$

$\boxed{\phantom{00}} - \frac{10}{4} = \bigcirc$

C  $\boxed{\phantom{00}} - \frac{10}{0} = \bigcirc$

B  $\boxed{\phantom{00}} - \frac{14}{4} = \bigcirc$

C  $\boxed{\phantom{00}} - \frac{14}{2} = \bigcirc$

|   | A   | B   | C   | D  |
|---|-----|-----|-----|----|
| E | 9,1 | 18  | 36  | 90 |
| F | 12  | 6,4 | 78  | 42 |
| G | 48  | 96  | 5,5 | 30 |
| H | 54  | 9,5 | 24  | 84 |
| I | 66  | 72  | 8,6 | 60 |

= A  
Total

$\frac{1}{6}$  of      =      B  
 $\frac{5}{6}$  of      =     

$\frac{3}{6}$  of      =      C  
 $\frac{1}{2}$  x      =      F

= D  
Total

$\frac{1}{6}$  of      =       
 $\frac{5}{6}$  x      =     

$\frac{2}{6}$  x      =      G  
 $\frac{1}{3}$  x      =      B

= E  
Total

$\frac{1}{4}$  of      =      H  
 $\frac{3}{4}$  x      =      J

$\frac{2}{4}$  x      =      I  
 $\frac{1}{2}$  x      =      F

= D  
Total

$\frac{1}{8}$  x      =      E  
 $\frac{3}{8}$  x      =     

$\frac{4}{8}$  x      =      C  
 $\frac{1}{2}$  x      =      H

12 's

|   |   |   |   |
|---|---|---|---|
| 2 | 6 | 6 | 2 |
| 4 | 6 | 5 | 2 |
| 3 | 6 | 7 | 2 |
| 9 | 4 | 4 | 4 |

13 's

|   |   |   |   |
|---|---|---|---|
| 4 | 3 | 6 | 7 |
| 4 | 8 | 4 | 3 |
| 5 | 3 | 2 | 3 |
| 4 | 9 | 5 | 8 |

|   | A  | B  | C  | D  |
|---|----|----|----|----|
| E | 24 | 0  | 28 | 2  |
| F | 3  | 21 | 12 | 10 |
| G | 20 | 4  | 30 | 16 |
| H | 6  | 15 | 8  | 26 |
| I | 14 | 9  | 5  | 12 |
| J | 7  | 18 | 22 | 9  |

"HOW MANY?"

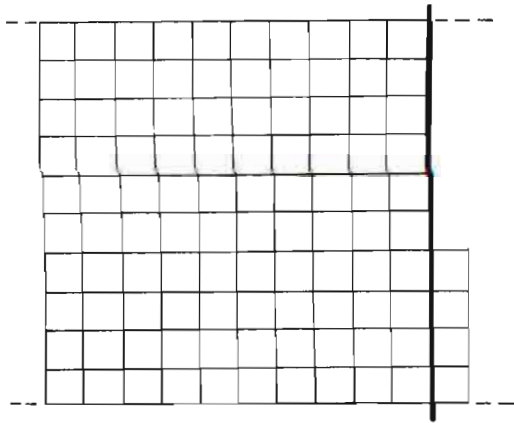

Total .....A

"¿CUANTOS?"

|  |  |  |
|--|--|--|
| $\begin{array}{r} 104 \\ - 4 \\ \hline \end{array}$  | $\begin{array}{r} 104 \\ - 7 \\ \hline \end{array}$  | $\begin{array}{r} 104 \\ - 17 \\ \hline \end{array}$ |
| —— B   | —— C   | —— D   |
| $\begin{array}{r} 204 \\ - 5 \\ \hline \end{array}$  | $\begin{array}{r} 204 \\ - 15 \\ \hline \end{array}$ | $\begin{array}{r} 204 \\ - 25 \\ \hline \end{array}$ |
| —— E   | —— F   | —— G   |
| $\begin{array}{r} 204 \\ - 10 \\ \hline \end{array}$ | $\begin{array}{r} 204 \\ - 40 \\ \hline \end{array}$ | $\begin{array}{r} 204 \\ - 45 \\ \hline \end{array}$ |
| —— H   | —— A   | —— B   |

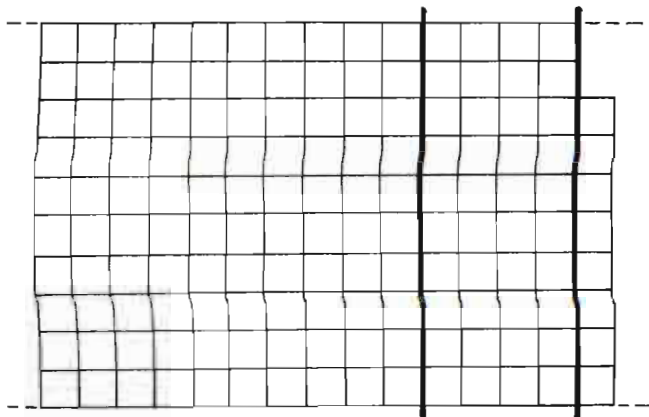

Total .....C

|  |  |  |
|--|--|--|
| $\begin{array}{r} 140 \\ - 40 \\ \hline \end{array}$ | $\begin{array}{r} 140 \\ - 50 \\ \hline \end{array}$ | $\begin{array}{r} 140 \\ - 51 \\ \hline \end{array}$ |
| —— B   | —— F   | —— B   |
| $\begin{array}{r} 148 \\ - 9 \\ \hline \end{array}$  | $\begin{array}{r} 148 \\ - 19 \\ \hline \end{array}$ | $\begin{array}{r} 148 \\ - 39 \\ \hline \end{array}$ |
| —— E   | ——   | —— B   |
| $\begin{array}{r} 148 \\ - 50 \\ \hline \end{array}$ | $\begin{array}{r} 148 \\ - 58 \\ \hline \end{array}$ | $\begin{array}{r} 148 \\ - 59 \\ \hline \end{array}$ |
| ——   | —— C   | —— D   |

TWO-WAY Chain Reactions

Reacción en Cadena en DOS MANERAS.

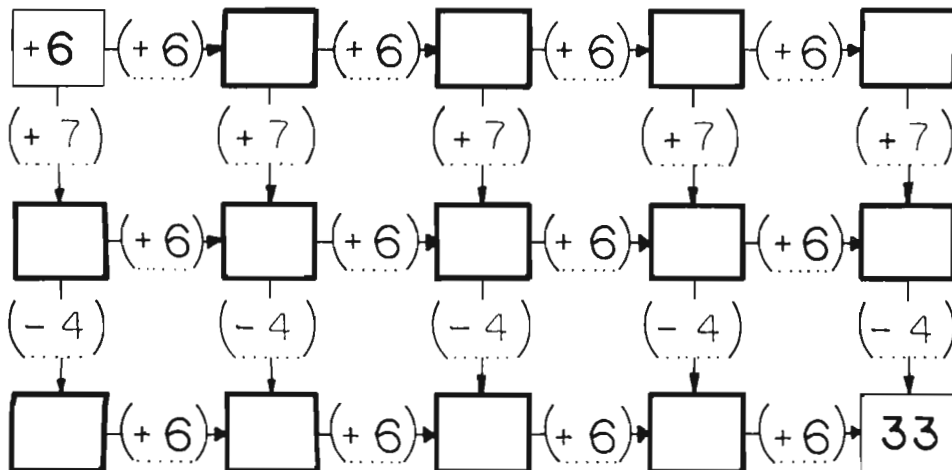

|   | A   | B   | C   |
|---|-----|-----|-----|
| D | 164 | 89  | 87  |
| E | 139 | 100 | 199 |
| F | 104 | 189 | 90  |
| G | 179 | 109 | 148 |
| H | 194 | 159 | 97  |

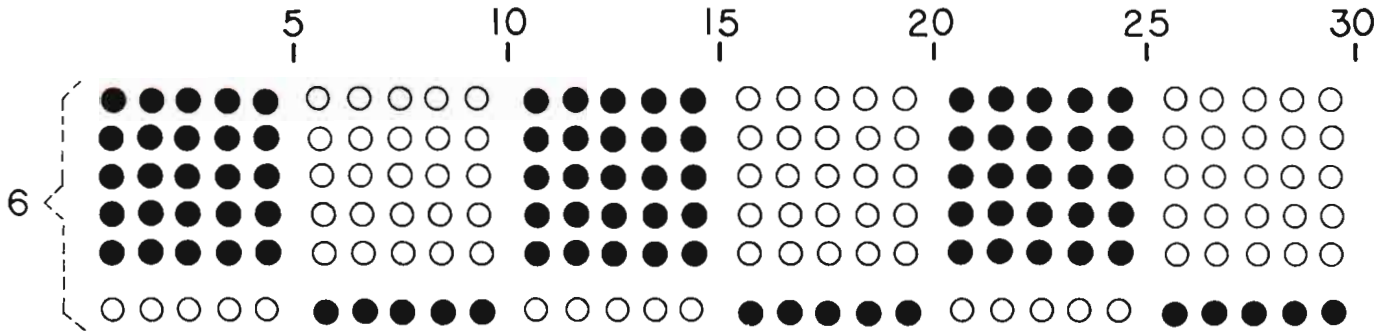

Please complete the tables

Favor de completar las tablas

|                    |                     |                        |                        |                    |                    |                    |                    |                    |
|--------------------|---------------------|------------------------|------------------------|--------------------|--------------------|--------------------|--------------------|--------------------|
| $6 \overline{) 6}$ | $6 \overline{) 12}$ | $6 \overline{) \quad}$ | $6 \overline{) \quad}$ | $6 \overline{) 5}$ | $6 \overline{) 6}$ | $6 \overline{) 7}$ | $6 \overline{) 8}$ | $6 \overline{) 9}$ |
|                    |                     | A                      | B                      | C                  | D                  | E                  | F                  | G                  |

|                     |                     |                     |                     |
|---------------------|---------------------|---------------------|---------------------|
| $6 \overline{) 18}$ | $6 \overline{) 12}$ | $6 \overline{) 30}$ | $6 \overline{) 60}$ |
|---------------------|---------------------|---------------------|---------------------|

|                    |                     |                     |                     |
|--------------------|---------------------|---------------------|---------------------|
| $6 \overline{) 6}$ | $6 \overline{) 12}$ | $6 \overline{) 24}$ | $6 \overline{) 48}$ |
|--------------------|---------------------|---------------------|---------------------|

|                |                |                |                |
|----------------|----------------|----------------|----------------|
| $\frac{6}{18}$ | $\frac{6}{36}$ | $\frac{6}{54}$ | $\frac{6}{60}$ |
| I              |                | A              |                |

|                     |                     |                     |                     |
|---------------------|---------------------|---------------------|---------------------|
| $6 \overline{) 60}$ | $6 \overline{) 12}$ | $6 \overline{) 72}$ | $6 \overline{) 78}$ |
|                     |                     |                     | B                   |

|                     |                     |                     |                      |
|---------------------|---------------------|---------------------|----------------------|
| $6 \overline{) 60}$ | $6 \overline{) 36}$ | $6 \overline{) 96}$ | $6 \overline{) 102}$ |
|                     |                     | C                   |                      |

|                |                |                |                |
|----------------|----------------|----------------|----------------|
| $\frac{6}{54}$ | $\frac{6}{48}$ | $\frac{6}{42}$ | $\frac{6}{36}$ |
|                |                | E              |                |

|                     |                     |                    |                |                |                |                     |                     |                     |
|---------------------|---------------------|--------------------|----------------|----------------|----------------|---------------------|---------------------|---------------------|
| $6 \overline{) 24}$ | $6 \overline{) 54}$ | $6 \overline{) 6}$ | $\frac{6}{18}$ | $\frac{6}{36}$ | $\frac{6}{42}$ | $6 \overline{) 12}$ | $6 \overline{) 48}$ | $6 \overline{) 30}$ |
|---------------------|---------------------|--------------------|----------------|----------------|----------------|---------------------|---------------------|---------------------|

Please loop "Neighbors" whose sum is given

Favor de poner un lazo a los "numeros vecinos" que dan la suma indicada.

|                |                |                |                |                |                |                |
|----------------|----------------|----------------|----------------|----------------|----------------|----------------|
| $\frac{7}{4}$  | $\frac{7}{4}$  | $\frac{7}{4}$  | $\frac{7}{4}$  | $\frac{7}{4}$  | $\frac{7}{4}$  | $\frac{7}{4}$  |
| $\frac{8}{3}$  | $\frac{8}{3}$  | $\frac{8}{3}$  | $\frac{8}{3}$  | $\frac{8}{3}$  | $\frac{8}{3}$  | $\frac{8}{3}$  |
| $\frac{5}{9}$  | $\frac{5}{9}$  | $\frac{5}{9}$  | $\frac{5}{9}$  | $\frac{5}{9}$  | $\frac{5}{9}$  | $\frac{5}{9}$  |
| $\frac{9}{14}$ | $\frac{9}{16}$ | $\frac{9}{36}$ | $\frac{9}{29}$ | $\frac{9}{27}$ | $\frac{9}{20}$ | $\frac{9}{17}$ |
| B              |                | F              | G              | I              |                |                |

|   | A                   | B   | C                 | D                   |
|---|---------------------|-----|-------------------|---------------------|
| E | 18                  | 5,9 | 9                 | 42                  |
| F | 11                  | 24  | 48                | $\frac{7,4}{3,5,9}$ |
| G | 10                  | 54  | 30                | $\frac{4,8,3}{5,9}$ |
| H | 60                  | 13  | $\frac{7,4}{8,3}$ | 36                  |
| I | $\frac{7,4,8}{3,5}$ | 3   | 16                | $\frac{4,8,3}{5,9}$ |

Please remember that this is one of several shortcuts to correct answers

Favor de recordar que este es uno de varios caminos cortos para obtener respuestas correctas.

|   |   |   |   |  |   |   |   |
|---|---|---|---|--|---|---|---|
| $\begin{array}{r}   \\ 39 \\ + 12 \\ \hline \end{array}$    | $\begin{array}{r} 39 \\ + 12 \\ \hline \end{array}$   | $\begin{array}{r} 4   \\ 51 \\ - 12 \\ \hline \end{array}$  | $\begin{array}{r} 51 \\ - 12 \\ \hline \end{array}$   | $\begin{array}{r}   \\ 15 \\ \times 3 \\ \hline \end{array}$   | $\begin{array}{r} 15 \\ \times 3 \\ \hline \end{array}$ | $\begin{array}{r}   \\ 3 \overline{) 45} \\ \hline \end{array}$   | $\begin{array}{r} 3 \overline{) 45} \\ \hline \end{array}$  |
| $\begin{array}{r}   \\ 35 \\ + 35 \\ \hline 0 \end{array}$  | $\begin{array}{r} 35 \\ + 35 \\ \hline \end{array}$   | $\begin{array}{r} 6   \\ 70 \\ - 35 \\ \hline \end{array}$  | $\begin{array}{r} 70 \\ - 35 \\ \hline \end{array}$   | $\begin{array}{r}   \\ 35 \\ \times 2 \\ \hline 0 \end{array}$ | $\begin{array}{r} 35 \\ \times 2 \\ \hline \end{array}$ | $\begin{array}{r} 3 \\ 2 \overline{) 70} \\ \hline \end{array}$   | $\begin{array}{r} 2 \overline{) 70} \\ \hline \end{array}$  |
| $\begin{array}{r}   \\ 147 \\ + 28 \\ \hline 5 \end{array}$ | $\begin{array}{r} 147 \\ + 28 \\ \hline \end{array}$  | $\begin{array}{r} 6   \\ 175 \\ - 28 \\ \hline \end{array}$ | $\begin{array}{r} 175 \\ - 28 \\ \hline \end{array}$  | $\begin{array}{r}   \\ 54 \\ \times 3 \\ \hline \end{array}$   | $\begin{array}{r} 54 \\ \times 3 \\ \hline \end{array}$ | $\begin{array}{r} 5 \\ 3 \overline{) 162} \\ \hline \end{array}$  | $\begin{array}{r} 3 \overline{) 162} \\ \hline \end{array}$ |
| $\begin{array}{r} 80 \\ + 89 \\ \hline 169 \end{array}$     | $\begin{array}{r} 85 \\ + 89 \\ \hline \end{array}$   | $\begin{array}{r} 174 \\ - 84 \\ \hline 90 \end{array}$     | $\begin{array}{r} 174 \\ - 89 \\ \hline \end{array}$  | $\begin{array}{r} 30 \\ \times 5 \\ \hline 150 \end{array}$    | $\begin{array}{r} 35 \\ \times 5 \\ \hline \end{array}$ | $\begin{array}{r} 30 \\ 5 \overline{) 150} \\ \hline \end{array}$ | $\begin{array}{r} 5 \overline{) 175} \\ \hline \end{array}$ |
| $\begin{array}{r} 124 \\ + 345 \\ \hline \end{array}$       | $\begin{array}{r} 124 \\ + 348 \\ \hline \end{array}$ | $\begin{array}{r} 472 \\ - 342 \\ \hline \end{array}$       | $\begin{array}{r} 472 \\ - 348 \\ \hline \end{array}$ | $\begin{array}{r} 20 \\ \times 8 \\ \hline \end{array}$        | $\begin{array}{r} 24 \\ \times 8 \\ \hline \end{array}$ | $\begin{array}{r} 20 \\ 8 \overline{) 160} \\ \hline \end{array}$ | $\begin{array}{r} 8 \overline{) 192} \\ \hline \end{array}$ |

"Regroup"?

¿"Regrupa"?

YES (Y) or NO (N)

|   |   |   |   |   |   |                     |                     |
|---|---|---|---|---|---|---------------------|---------------------|
| Y N   | Y N   | Y N   | Y N   | Y N   | Y N   | Y N                 | Y N                 |
| $\begin{array}{r} 74 \\ + 16 \\ \hline \end{array}$ | $\begin{array}{r} 67 \\ + 32 \\ \hline \end{array}$ | $\begin{array}{r} 45 \\ - 24 \\ \hline \end{array}$ | $\begin{array}{r} 80 \\ - 51 \\ \hline \end{array}$ | $\begin{array}{r} 15 \\ \times 2 \\ \hline \end{array}$ | $\begin{array}{r} 21 \\ \times 4 \\ \hline \end{array}$ | $2 \overline{) 36}$ | $2 \overline{) 58}$ |
| A   | B   | E   | C   | A   | E   | D                   | C                   |

|   | A   | B   | C   | D   | E   |
|---|-----|-----|-----|-----|-----|
| F | 162 | 24  | 124 | 15  | 175 |
| G | 35  | 39  | 174 | 85  | 147 |
| H | Y   | N   | Y   | Y   | N   |
| I | 51  | 472 | 45  | 192 | 70  |
|   | Y   | 54  | Y   | 175 | N   |

BOOK  
15 ¢

| books | total  |   |
|-------|--------|---|
| 1     | 15 ¢   |   |
| 2     | ¢      | A |
| 4     | ¢      | B |
|       | \$1.20 | C |
| 5     | ¢      |   |
|       | \$1.50 | D |
| 20    | \$     | E |

50 MILES/1 HOUR

| HOURS                | MILES |   |
|----------------------|-------|---|
| 1                    | 50    |   |
| 3                    |       |   |
| 5                    |       | F |
| $\frac{1}{5}$ (min)  |       | G |
|                      | 25    |   |
| $\frac{1}{10}$ (min) |       | I |
|                      | 75    | J |

1 CARTON  
6 CANS

| cartons | cans |   |
|---------|------|---|
| 1       | 6    |   |
| 2       |      |   |
|         | 18   |   |
|         | 30   | D |
|         | 48   | C |
| 9       |      | D |
|         | 42   |   |

1 DAY = 24 HOURS

| days           | hours |   |
|----------------|-------|---|
| 1              | 24    |   |
| 2              |       | G |
| $\frac{1}{2}$  |       | H |
| $\frac{1}{3}$  |       | I |
| $\frac{1}{4}$  |       | J |
| $\frac{1}{6}$  |       | A |
| $1\frac{1}{3}$ |       | G |
| $2\frac{1}{2}$ |       | H |

1 M = 100 CM

| M               | CM  |   |
|-----------------|-----|---|
| 1               | 100 |   |
| $\frac{1}{2}$   |     | I |
| $\frac{1}{4}$   |     | B |
| $\frac{3}{4}$   |     | E |
| $\frac{1}{10}$  |     | G |
| $1\frac{1}{2}$  |     | H |
| $2\frac{1}{10}$ |     | I |
| $5\frac{3}{10}$ |     | J |

1 YARD =  
36 inches

| yards         | inches |   |
|---------------|--------|---|
| $\frac{1}{2}$ |        | H |
| $\frac{1}{3}$ |        | D |
| $\frac{1}{4}$ |        |   |
| $\frac{1}{6}$ |        | J |

|   | A  | B              | C   | D  | E             | F             |
|---|----|----------------|-----|----|---------------|---------------|
| G | 4  | 25             | 48  | 10 | 75            | 32            |
| H | 18 | 60             | 150 | 12 | $\frac{1}{2}$ | 250           |
| I | 50 | 30             | 8   | 5  | 210           | $\frac{1}{3}$ |
| J | 30 | $1\frac{1}{2}$ | 530 | 54 | 300           | 6             |

**Addition**  
Sumas

$$\begin{array}{r} 100 \\ + 16 \\ \hline \end{array} \quad \begin{array}{r} 116 \\ + 30 \\ \hline \end{array}$$

$$\begin{array}{r} 116 \\ + 4 \\ \hline \end{array} \quad \begin{array}{r} 116 \\ + 54 \\ \hline \end{array}$$

$$\begin{array}{r} 112 \\ + 18 \\ \hline \end{array} \quad \begin{array}{r} 125 \\ + 75 \\ \hline \end{array}$$

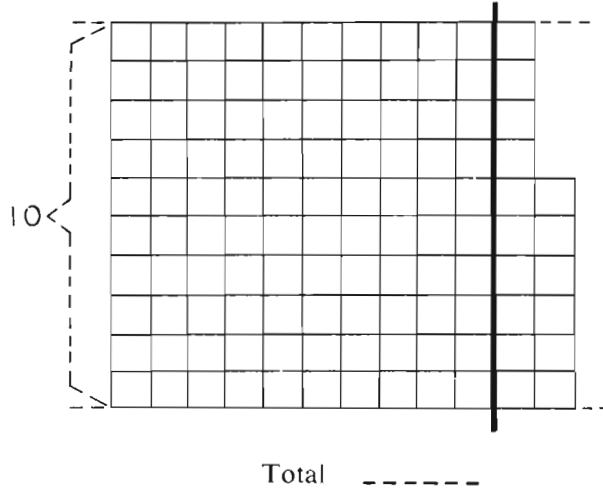

**Subtraction**  
Diferencias

$$\begin{array}{r} 100 \\ - 10 \\ \hline \end{array} \quad \begin{array}{r} 116 \\ - 9 \\ \hline \end{array}$$

$$\begin{array}{r} 116 \\ - 16 \\ \hline \end{array} \quad \begin{array}{r} 116 \\ - 18 \\ \hline \end{array}$$

$$\begin{array}{r} 116 \\ - 20 \\ \hline \end{array} \quad \begin{array}{r} 116 \\ - 51 \\ \hline \end{array}$$

|            |            |            |            |            |            |            |            |            |            |            |            |            |            |
|------------|------------|------------|------------|------------|------------|------------|------------|------------|------------|------------|------------|------------|------------|
| 0          | 1          | 2          | 3          | 4          | 5          | 6          | 7          | 8          | 9          | 10         | 11         | 12         | 13         |
| $\times 6$ | $\times 6$ | $\times 6$ | $\times 6$ | $\times 6$ | $\times 6$ | $\times 6$ | $\times 6$ | $\times 6$ | $\times 6$ | $\times 6$ | $\times 6$ | $\times 6$ | $\times 6$ |

|            |            |            |
|------------|------------|------------|
| 4          | 10         | 14         |
| $\times 6$ | $\times 6$ | $\times 6$ |

|            |            |            |
|------------|------------|------------|
| 10         | 30         | 40         |
| $\times 6$ | $\times 6$ | $\times 6$ |

|            |            |            |
|------------|------------|------------|
| 7          | 20         | 27         |
| $\times 6$ | $\times 6$ | $\times 6$ |

|            |            |            |
|------------|------------|------------|
| 8          | 9          | 17         |
| $\times 6$ | $\times 6$ | $\times 6$ |

|                     |                    |                     |                     |
|---------------------|--------------------|---------------------|---------------------|
| $6 \overline{)60}$  | $6 \overline{)24}$ | $6 \overline{)84}$  | $6 \overline{)90}$  |
| $6 \overline{)120}$ | $6 \overline{)12}$ | $6 \overline{)132}$ | $6 \overline{)138}$ |
| $6 \overline{)24}$  | $6 \overline{)48}$ | $6 \overline{)72}$  | $6 \overline{)96}$  |



How do you feel?  
¿Cómo se siente?

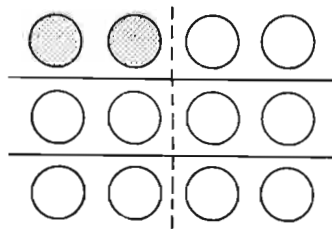

Total

$$\frac{1}{6} \text{ of } \underline{12} = \text{-----}$$

$$\frac{3}{6} \times \underline{12} = \text{-----}$$

$$\frac{5}{6} \times \underline{12} = \text{-----}$$

$$\frac{1}{2} \times \underline{12} = \text{-----}$$

$$1 \text{ (25¢)} = 5 \text{ (5¢)}$$

1 DOLLAR....  
...100 CENTS

|               |      |
|---------------|------|
| (25¢)         | (5¢) |
| 1             |      |
| 3             |      |
| $\frac{1}{5}$ |      |
| $\frac{2}{5}$ |      |
| 10            |      |

|                   |       |
|-------------------|-------|
| dollars           | cents |
| 1                 |       |
| $\frac{1}{2}$     |       |
| $\frac{1}{4}$     |       |
| $\frac{1}{10}$    |       |
| $3 \frac{1}{100}$ |       |



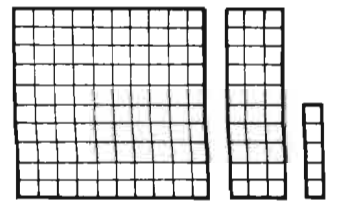
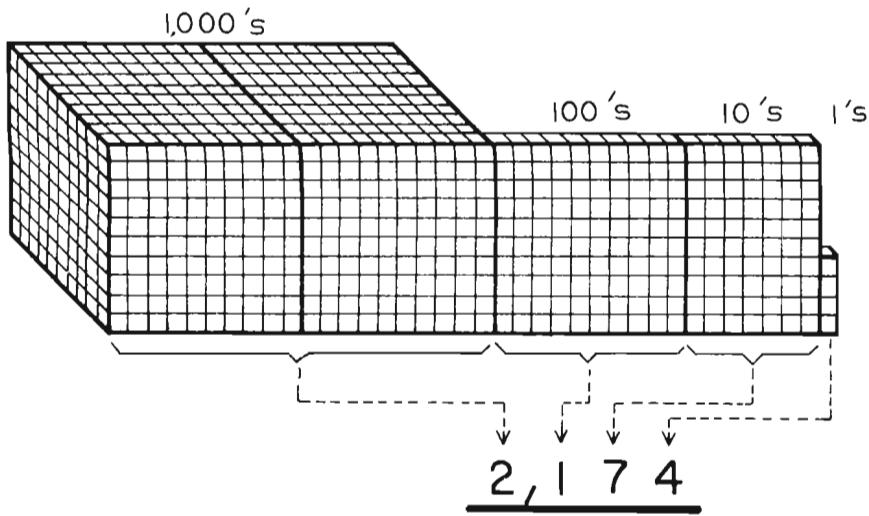

A -----

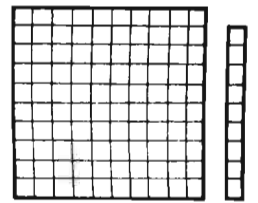

B -----

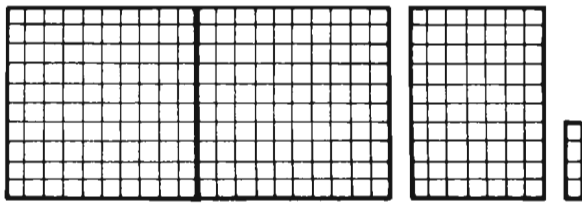

A -----

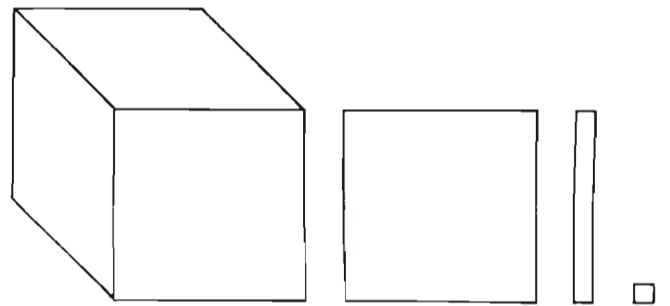

B -----

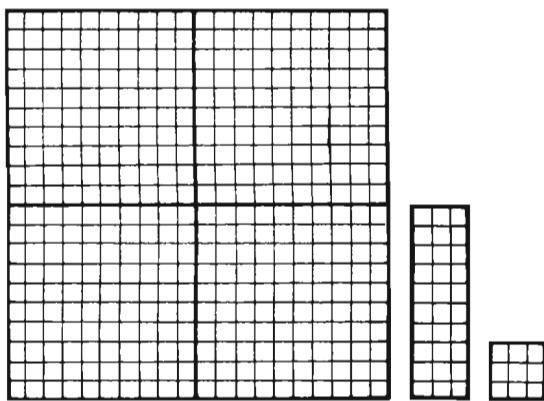

A -----

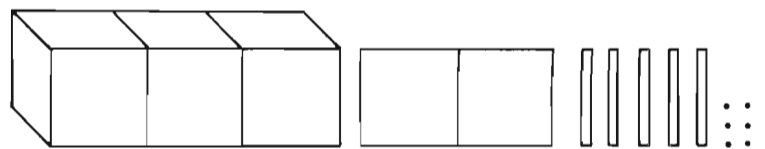

B -----

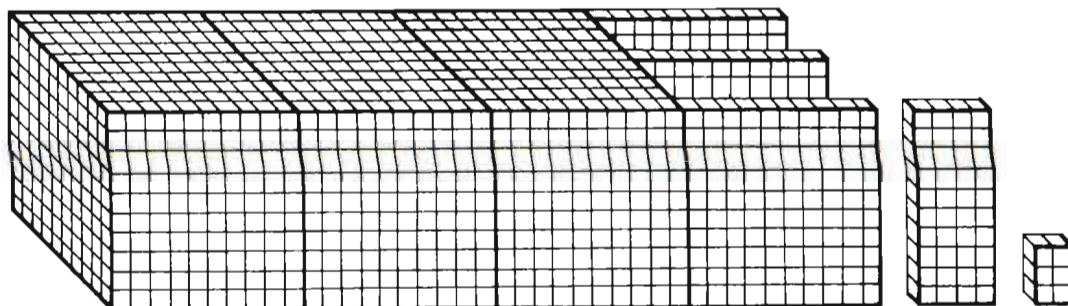

A -----

| A     | B     |
|-------|-------|
| 3,126 | 3,256 |
| 135   | 207   |
| 513   | 1,111 |
| 3,024 | 109   |
| 439   | 3,169 |
| 968   | 279   |
| 3,346 | 1,003 |
| 274   | 4,126 |

"HOW MANY?"

"¿CUANTOS?"

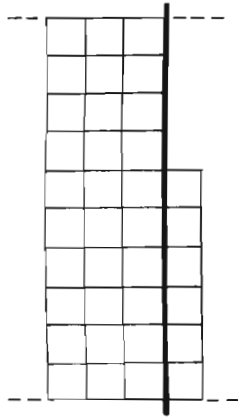

Total .....A

$$\begin{array}{r} 36 \\ + 4 \\ \hline \end{array}$$

.....

$$\begin{array}{r} 34 \\ + 19 \\ \hline \end{array}$$

.....C

$$\begin{array}{r} 36 \\ \times 2 \\ \hline \end{array}$$

.....C

$$\begin{array}{r} 36 \\ + 14 \\ \hline \end{array}$$

.....B

$$\begin{array}{r} 36 \\ + 36 \\ \hline \end{array}$$

.....D

$$\begin{array}{r} 36 \\ \times 3 \\ \hline \end{array}$$

.....B

$$\begin{array}{r} 34 \\ + 16 \\ \hline \end{array}$$

.....D

$$\begin{array}{r} 72 \\ + 36 \\ \hline \end{array}$$

.....E

$$\begin{array}{r} 36 \\ \div 2 \\ \hline \end{array}$$

.....H

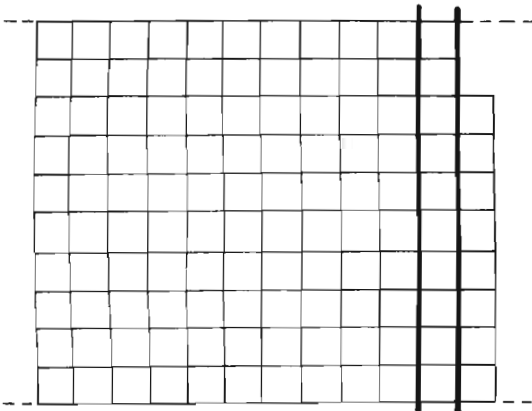

Total .....G

$$\begin{array}{r} 100 \\ + 18 \\ \hline \end{array}$$

.....B

$$\begin{array}{r} 118 \\ + 900 \\ \hline \end{array}$$

.....J

$$\begin{array}{r} 118 \\ \times 2 \\ \hline \end{array}$$

.....E

$$\begin{array}{r} 118 \\ + 12 \\ \hline \end{array}$$

.....

$$\begin{array}{r} 118 \\ + 118 \\ \hline \end{array}$$

.....A

$$\begin{array}{r} 118 \\ \times 3 \\ \hline \end{array}$$

.....E

$$\begin{array}{r} 112 \\ + 78 \\ \hline \end{array}$$

.....I

$$\begin{array}{r} 236 \\ + 118 \\ \hline \end{array}$$

.....C

$$\begin{array}{r} 118 \\ \div 2 \\ \hline \end{array}$$

.....F

Loop Arithmetic

$$\begin{array}{ccc} 3 & 3 & 3 \\ 5 & 5 & 5 \end{array} \quad \textcircled{16}^A$$

$$\begin{array}{ccc} 3 & 3 & 3 \\ 5 & 5 & 5 \end{array} \quad \textcircled{14}$$

Aritmética de Lazo

$$\begin{array}{ccc} 2 & 2 & 2 \\ 7 & 7 & 7 \end{array} \quad \textcircled{18}$$

$$\begin{array}{ccc} 2 & 2 & 2 \\ 7 & 7 & 7 \end{array} \quad \textcircled{13}^H$$

$$\begin{array}{ccc} 2 & 2 & 2 \\ 7 & 7 & 7 \end{array} \quad \textcircled{23}^H$$

$$\begin{array}{ccc} 5 & 5 & 5 \\ 6 & 6 & 6 \end{array} \quad \textcircled{22}$$

$$\begin{array}{ccc} 5 & 5 & 5 \\ 6 & 6 & 6 \end{array} \quad \textcircled{21}^I$$

$$\begin{array}{ccc} 5 & 5 & 5 \\ 6 & 6 & 6 \end{array} \quad \textcircled{17}^J$$

|   | A   | B     | C                                       |
|---|---|-------|---|
| D | $\begin{array}{c} 3,3 \\ 5,5 \end{array}$ | 50    | 72                                      |
| E | 236                                       | 108   | 354                                     |
| F | 36  | 48    | 59                                      |
| G | $\begin{array}{c} 3,3,3 \\ 5 \end{array}$ | 118   | 53                                      |
| H | $\begin{array}{c} 2 \\ 7,7,7 \end{array}$ | 18    | $\begin{array}{c} 222 \\ 7 \end{array}$ |
| I | $\begin{array}{c} 5 \\ 6,6,6 \end{array}$ | 190   | $\begin{array}{c} 555 \\ 6 \end{array}$ |
| J | $\begin{array}{c} 5,6,6 \end{array}$      | 6,4,5 | 1,0,18                                  |

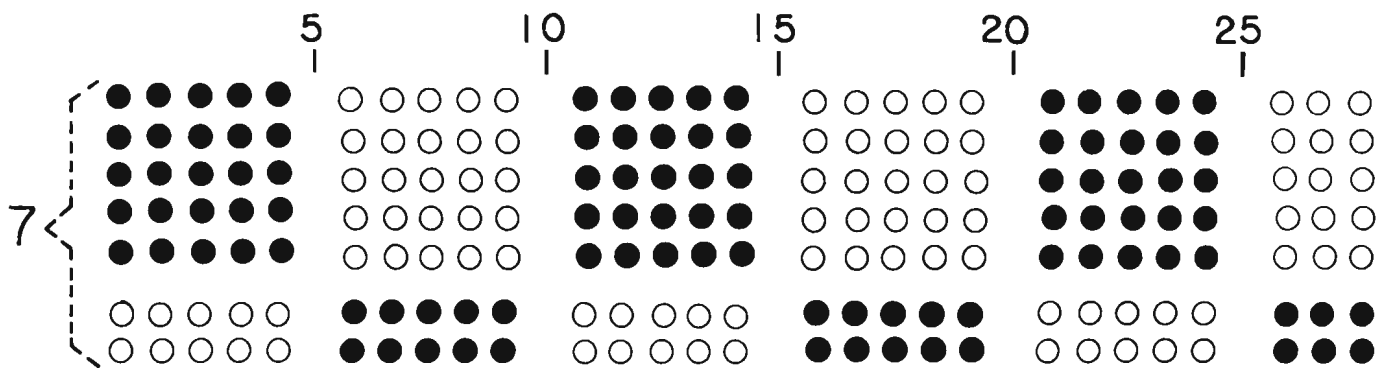

Please complete the tables

Favor de completar las tablas

|  |  |  |  |  |  |  |  |  |  |   |   |   |   |
|--|--|--|--|--|--|--|--|--|--|---|---|---|---|
| $\begin{array}{r} 0 \\ \times 7 \\ \hline 0 \end{array}$ | $\begin{array}{r} 1 \\ \times 7 \\ \hline ? \end{array}$ | $\begin{array}{r} 2 \\ \times 7 \\ \hline \end{array}$ | $\begin{array}{r} 3 \\ \times 7 \\ \hline \end{array}$ | $\begin{array}{r} 4 \\ \times 7 \\ \hline \end{array}$ | $\begin{array}{r} 5 \\ \times 7 \\ \hline \end{array}$ | $\begin{array}{r} 6 \\ \times 7 \\ \hline \end{array}$ | $\begin{array}{r} 7 \\ \times 7 \\ \hline \end{array}$ | $\begin{array}{r} 8 \\ \times 7 \\ \hline \end{array}$ | $\begin{array}{r} 9 \\ \times 7 \\ \hline \end{array}$ | $\begin{array}{r} 10 \\ \times 7 \\ \hline \end{array}$ | $\begin{array}{r} 11 \\ \times 7 \\ \hline \end{array}$ | $\begin{array}{r} 12 \\ \times 7 \\ \hline \end{array}$ | $\begin{array}{r} 13 \\ \times 7 \\ \hline \end{array}$ |
| A  | B  | C  | D  | E  | F  | G  | H  | I  | J  | A   | B   |   |   |

|   |  |  |   |   |
|---|--|--|---|---|
| $\begin{array}{r} 10 \\ \times 7 \\ \hline \end{array}$ | $\begin{array}{r} 5 \\ \times 7 \\ \hline \end{array}$ | $\begin{array}{r} 6 \\ \times 7 \\ \hline \end{array}$ | $\begin{array}{r} 12 \\ \times 7 \\ \hline \end{array}$ | $\begin{array}{r} 13 \\ \times 7 \\ \hline \end{array}$ |
|---|--|--|---|---|

|  |  |  |  |
|--|--|--|--|
| $\begin{array}{r} 7 \\ \times 1 \\ \hline \end{array}$ | $\begin{array}{r} 7 \\ \times 2 \\ \hline \end{array}$ | $\begin{array}{r} 7 \\ \times 4 \\ \hline \end{array}$ | $\begin{array}{r} 7 \\ \times 8 \\ \hline \end{array}$ |
|--|--|--|--|

|  |  |  |
|--|--|--|
| $\begin{array}{r} 3 \\ \times 7 \\ \hline \end{array}$ | $\begin{array}{r} 6 \\ \times 7 \\ \hline \end{array}$ | $\begin{array}{r} 9 \\ \times 7 \\ \hline \end{array}$ |
|--|--|--|

|  |   |   |   |
|--|---|---|---|
| $\begin{array}{r} 4 \\ \times 7 \\ \hline \end{array}$ | $\begin{array}{r} 10 \\ \times 7 \\ \hline \end{array}$ | $\begin{array}{r} 14 \\ \times 7 \\ \hline \end{array}$ | $\begin{array}{r} 15 \\ \times 7 \\ \hline \end{array}$ |
| C  | D   |   |   |

|  |  |  |  |
|--|--|--|--|
| $\begin{array}{r} 7 \\ \times 9 \\ \hline \end{array}$ | $\begin{array}{r} 7 \\ \times 8 \\ \hline \end{array}$ | $\begin{array}{r} 7 \\ \times 7 \\ \hline \end{array}$ | $\begin{array}{r} 7 \\ \times 6 \\ \hline \end{array}$ |
|--|--|--|--|

|  |   |   |   |
|--|---|---|---|
| $\begin{array}{r} 5 \\ \times 7 \\ \hline \end{array}$ | $\begin{array}{r} 10 \\ \times 7 \\ \hline \end{array}$ | $\begin{array}{r} 15 \\ \times 7 \\ \hline \end{array}$ | $\begin{array}{r} 30 \\ \times 7 \\ \hline \end{array}$ |
| F  | F   |   |   |

|   |  |   |  |  |  |   |  |   |  |  |  |   |   |
|---|--|---|--|--|--|---|--|---|--|--|--|---|---|
| $\begin{array}{r} 10 \\ \times 7 \\ \hline \end{array}$ | $\begin{array}{r} 2 \\ \times 7 \\ \hline \end{array}$ | $\begin{array}{r} 12 \\ \times 7 \\ \hline \end{array}$ | $\begin{array}{r} 7 \\ \times 3 \\ \hline \end{array}$ | $\begin{array}{r} 7 \\ \times 6 \\ \hline \end{array}$ | $\begin{array}{r} 7 \\ \times 9 \\ \hline \end{array}$ | $\begin{array}{r} 10 \\ \times 7 \\ \hline \end{array}$ | $\begin{array}{r} 3 \\ \times 7 \\ \hline \end{array}$ | $\begin{array}{r} 13 \\ \times 7 \\ \hline \end{array}$ | $\begin{array}{r} 7 \\ \times 2 \\ \hline \end{array}$ | $\begin{array}{r} 7 \\ \times 4 \\ \hline \end{array}$ | $\begin{array}{r} 7 \\ \times 8 \\ \hline \end{array}$ | $\begin{array}{r} 10 \\ \times 7 \\ \hline \end{array}$ | $\begin{array}{r} 20 \\ \times 7 \\ \hline \end{array}$ |
| G   |  |   |  |  |  |   |  |   |  |  |  |   |   |

Domino Puzzles

Rompecabezas de Dóminos

Addition

Suma

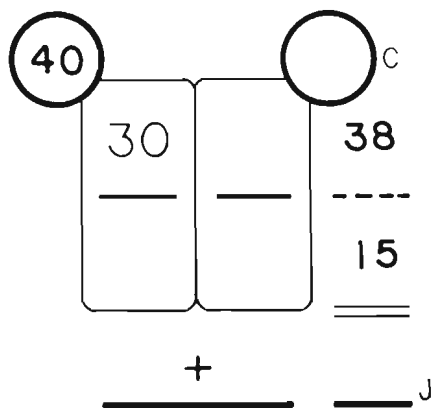
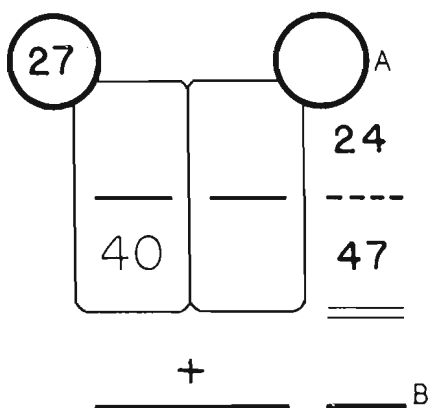

|   |    |     |     |     |
|---|----|-----|-----|-----|
|   | A  | B   | C   | D   |
| E | 31 | 91  | 43  | 42  |
| F | 14 | 49  | 210 | 105 |
| G | 84 | 140 | 28  | 56  |
| H | 63 | 21  | 98  | 37  |
| I | 41 | 70  | 13  | 35  |
| J | 44 | 71  | 77  | 53  |

Total = A

$\frac{1}{8}$  of A = 1

$\frac{6}{8}$  of A = C

$\frac{1}{4}$  x A = D

$\frac{3}{4}$  x A = H

= E

$\frac{4}{6}$  of E = F

$\frac{2}{6}$  x E = G

$\frac{2}{3}$  x E = D

$\frac{1}{3}$  x E = D

= G

$\frac{2}{4}$  of G = H

$\frac{1}{4}$  x G = I

$\frac{1}{2}$  x G = B

$\frac{3}{4}$  x G = J

= A

$\frac{3}{4}$  x A = B

$\frac{2}{4}$  x A = C

$\frac{1}{4}$  x A = D

$\frac{1}{2}$  x A = E

|                      |                      |                      |
|----------------------|----------------------|----------------------|
| 25                   | 5                    | 1                    |
| <input type="text"/> | <input type="text"/> | <input type="text"/> |

31

B

|                      |                      |                      |
|----------------------|----------------------|----------------------|
| 25                   | 5                    | 1                    |
| <input type="text"/> | <input type="text"/> | <input type="text"/> |

37

B

|                      |                      |                      |
|----------------------|----------------------|----------------------|
| 25                   | 5                    | 1                    |
| <input type="text"/> | <input type="text"/> | <input type="text"/> |

64

F

|                      |                      |                      |
|----------------------|----------------------|----------------------|
| 36                   | 6                    | 1                    |
| <input type="text"/> | <input type="text"/> | <input type="text"/> |

27

J

|                      |                      |                      |
|----------------------|----------------------|----------------------|
| 36                   | 6                    | 1                    |
| <input type="text"/> | <input type="text"/> | <input type="text"/> |

45

C

|                      |                      |                      |
|----------------------|----------------------|----------------------|
| 36                   | 6                    | 1                    |
| <input type="text"/> | <input type="text"/> | <input type="text"/> |

79

A

|                      |                      |                      |
|----------------------|----------------------|----------------------|
| 49                   | 7                    | 1                    |
| <input type="text"/> | <input type="text"/> | <input type="text"/> |

56

H

|                      |                      |                      |
|----------------------|----------------------|----------------------|
| 49                   | 7                    | 1                    |
| <input type="text"/> | <input type="text"/> | <input type="text"/> |

45

A

|                      |                      |                      |
|----------------------|----------------------|----------------------|
| 49                   | 7                    | 1                    |
| <input type="text"/> | <input type="text"/> | <input type="text"/> |

70

C

|   | A     | B     | C     | D     |
|---|-------|-------|-------|-------|
| E | 36    | 1,2,2 | 20    | 10    |
| F | 2,2,4 | 24    | 1,2,4 | 8     |
| G | 32    | 1,1,1 | 36    | 12    |
| H | 0,6,3 | 18    | 24    | 1,1,0 |
| I | 40    | 30    | 1,3,0 | 9     |
| J | 2,1,1 | 27    | 1,1,3 | 0,4,3 |

"HOW MANY?"

"¿CUANTOS?"

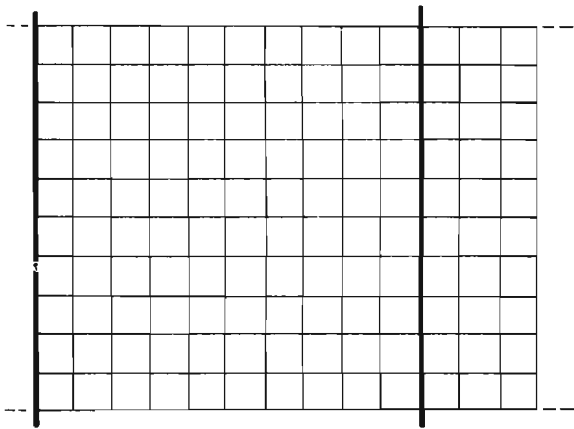

Total .....A

$$\begin{array}{r} 100 \\ + 30 \\ \hline \end{array}$$

.....H

$$\begin{array}{r} 130 \\ - 5 \\ \hline \end{array}$$

.....E

$$\begin{array}{r} 130 \\ - 105 \\ \hline \end{array}$$

.....H

$$\begin{array}{r} 130 \\ - 30 \\ \hline \end{array}$$

.....C

$$\begin{array}{r} 130 \\ - 25 \\ \hline \end{array}$$

.....F

$$\begin{array}{r} 130 \\ \times 2 \\ \hline \end{array}$$

.....E

$$\begin{array}{r} 130 \\ - 40 \\ \hline \end{array}$$

.....D

$$\begin{array}{r} 130 \\ - 45 \\ \hline \end{array}$$

.....G

$$\begin{array}{r} 130 \\ \times 3 \\ \hline \end{array}$$

.....B

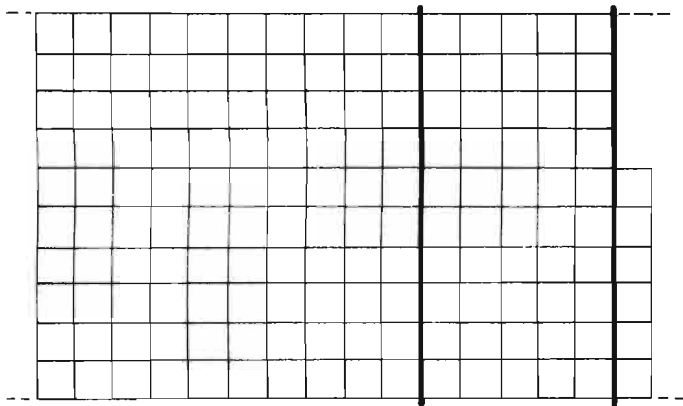

Total .....C

$$\begin{array}{r} 50 \\ + 56 \\ \hline \end{array}$$

.....D

$$\begin{array}{r} 156 \\ - 57 \\ \hline \end{array}$$

.....G

$$\begin{array}{r} 156 \\ + 150 \\ \hline \end{array}$$

.....

$$\begin{array}{r} 156 \\ - 7 \\ \hline \end{array}$$

.....E

$$\begin{array}{r} 156 \\ - 87 \\ \hline \end{array}$$

.....

$$\begin{array}{r} 156 \\ + 156 \\ \hline \end{array}$$

.....B

$$\begin{array}{r} 156 \\ - 27 \\ \hline \end{array}$$

.....F

$$\begin{array}{r} 156 \\ - 107 \\ \hline \end{array}$$

.....

$$\begin{array}{r} 156 \\ \times 2 \\ \hline \end{array}$$

.....H

14's

15's

|   |   |    |   |   |
|---|---|----|---|---|
| 2 | 1 | 7  | 7 | 8 |
| 4 | 5 | 6  | 2 | 6 |
| 8 | 9 | 8  | 5 | 9 |
| 6 | 4 | 5  | 9 | 3 |
| 7 | 3 | 11 | 3 | 2 |

|   |   |   |   |   |
|---|---|---|---|---|
| 6 | 9 | 4 | 7 | 4 |
| 3 | 1 | 5 | 4 | 5 |
| 6 | 8 | 3 | 4 | 1 |
| 9 | 4 | 5 | 3 | 2 |
| 6 | 5 | 5 | 8 | 3 |

|   | A   | B   | C   |
|---|-----|-----|-----|
| D | 106 | 90  | 100 |
| E | 125 | 260 | 149 |
| F | 129 | 390 | 105 |
| G | 99  | 85  | 156 |
| H | 130 | 312 | 25  |

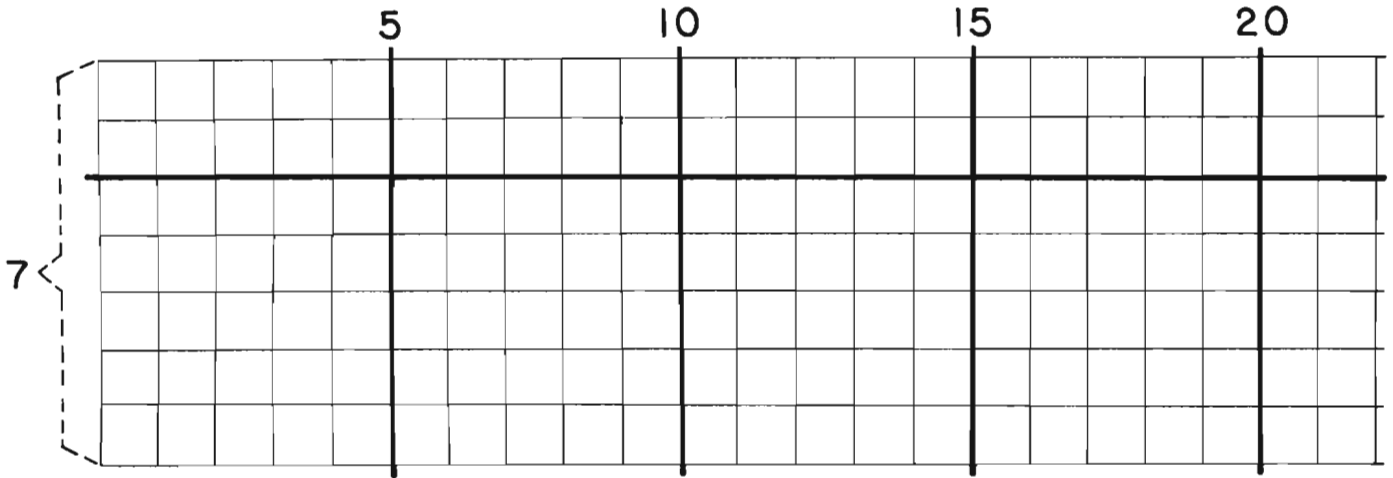

|                   |                   |                   |                   |                   |                   |                   |                   |                   |
|-------------------|-------------------|-------------------|-------------------|-------------------|-------------------|-------------------|-------------------|-------------------|
| $7 \overline{)1}$ | $7 \overline{)2}$ | $7 \overline{)3}$ | $7 \overline{)4}$ | $7 \overline{)5}$ | $7 \overline{)6}$ | $7 \overline{)7}$ | $7 \overline{)8}$ | $7 \overline{)9}$ |
| A                 | B                 | C                 | D                 | E                 | F                 | G                 | H                 | I                 |

|                    |                    |                    |                    |
|--------------------|--------------------|--------------------|--------------------|
| $7 \overline{)21}$ | $7 \overline{)42}$ | $7 \overline{)63}$ | $7 \overline{)84}$ |
| J                  |                    |                    |                    |

|                   |                   |                    |                    |
|-------------------|-------------------|--------------------|--------------------|
| $7 \overline{)4}$ | $7 \overline{)6}$ | $7 \overline{)10}$ | $7 \overline{)16}$ |
| A                 |                   | B                  |                    |

|                   |                   |                   |                   |
|-------------------|-------------------|-------------------|-------------------|
| $2 \overline{)7}$ | $3 \overline{)7}$ | $5 \overline{)7}$ | $7 \overline{)7}$ |
|-------------------|-------------------|-------------------|-------------------|

|                  |                  |                  |                  |
|------------------|------------------|------------------|------------------|
| $\overline{)42}$ | $\overline{)56}$ | $\overline{)49}$ | $\overline{)63}$ |
|------------------|------------------|------------------|------------------|

|                   |                    |                    |                    |
|-------------------|--------------------|--------------------|--------------------|
| $7 \overline{)9}$ | $7 \overline{)10}$ | $7 \overline{)19}$ | $7 \overline{)20}$ |
| A                 | E                  | F                  |                    |

|                    |                    |                    |                    |
|--------------------|--------------------|--------------------|--------------------|
| $7 \overline{)30}$ | $7 \overline{)40}$ | $7 \overline{)50}$ | $7 \overline{)60}$ |
| G                  | H                  | I                  | J                  |

|                    |                    |                    |                    |                    |                    |                    |                    |                   |
|--------------------|--------------------|--------------------|--------------------|--------------------|--------------------|--------------------|--------------------|-------------------|
| $7 \overline{)21}$ | $7 \overline{)49}$ | $7 \overline{)28}$ | $7 \overline{)42}$ | $7 \overline{)63}$ | $7 \overline{)14}$ | $7 \overline{)35}$ | $7 \overline{)56}$ | $7 \overline{)7}$ |
|--------------------|--------------------|--------------------|--------------------|--------------------|--------------------|--------------------|--------------------|-------------------|

|   |   |   |   |   |
|---|---|---|---|---|
| $\begin{array}{r} 32 \\ 32 \\ + 32 \\ \hline \end{array}$ | $\begin{array}{r} 43 \\ 43 \\ + 43 \\ \hline \end{array}$ | $\begin{array}{r} 25 \\ 25 \\ + 25 \\ \hline \end{array}$ | $\begin{array}{r} 19 \\ 19 \\ + 19 \\ \hline \end{array}$ | $\begin{array}{r} 83 \\ 83 \\ + 83 \\ \hline \end{array}$ |
|   | A   |   | F   | C   |

|   |   |   |   |   |
|---|---|---|---|---|
| $\begin{array}{r} 62 \\ 62 \\ + 62 \\ \hline \end{array}$ | $\begin{array}{r} 26 \\ 26 \\ + 26 \\ \hline \end{array}$ | $\begin{array}{r} 73 \\ 73 \\ + 73 \\ \hline \end{array}$ | $\begin{array}{r} 37 \\ 37 \\ + 37 \\ \hline \end{array}$ | $\begin{array}{r} 99 \\ 99 \\ + 99 \\ \hline \end{array}$ |
|   | F   |   | J   | C   |

|   |     |     |     |     |
|---|-----|-----|-----|-----|
|   | A   | B   | C   | D   |
| E | 70  | 133 | 21  | 35  |
| F | 78  | 42  | 57  | 140 |
| G | 7   | 112 | 49  | 210 |
| H | 129 | 280 | 249 | 56  |
| I | 350 | 63  | 297 | 28  |
| J | 111 | 14  | 12  | 420 |

Please remember that this is one of several shortcuts to correct answers

Favor de recordar que este es uno de varios caminos cortos para obtener respuestas correctas.

|                                  |                           |
|----------------------------------|---------------------------|
| 1<br>24<br>25<br>+ 26<br><hr/> 5 | 24<br>25<br>+ 26<br><hr/> |
|----------------------------------|---------------------------|

A

|  |                                     |
|--|-------------------------------------|
| 1<br>124<br>124<br>214<br>+ 334<br><hr/> 6 | 124<br>124<br>214<br>+ 334<br><hr/> |
|--|-------------------------------------|

B

|   |   |                                    |
|---|---|------------------------------------|
| 2<br>146<br>46<br>346<br>+ 106<br><hr/> 4 | 12<br>146<br>46<br>346<br>+ 106<br><hr/> 44 | 146<br>46<br>346<br>+ 106<br><hr/> |
|---|---|------------------------------------|

C

|                              |                       |
|------------------------------|-----------------------|
| 8<br>493<br>- 127<br><hr/> 6 | 493<br>- 127<br><hr/> |
|------------------------------|-----------------------|

D

|                              |                                |                       |
|------------------------------|--------------------------------|-----------------------|
| 2<br>537<br>- 198<br><hr/> 9 | 42<br>537<br>- 198<br><hr/> 39 | 537<br>- 198<br><hr/> |
|------------------------------|--------------------------------|-----------------------|

A

|                            |                            |                       |
|----------------------------|----------------------------|-----------------------|
| 1<br>724<br>- 366<br><hr/> | 6<br>724<br>- 366<br><hr/> | 724<br>- 366<br><hr/> |
|----------------------------|----------------------------|-----------------------|

B

|                            |                     |
|----------------------------|---------------------|
| 3<br>218<br>x 4<br><hr/> 2 | 218<br>x 4<br><hr/> |
|----------------------------|---------------------|

C

|                             |                     |
|-----------------------------|---------------------|
| 1<br>243<br>x 3<br><hr/> 29 | 243<br>x 3<br><hr/> |
|-----------------------------|---------------------|

D

|                             |                              |                     |
|-----------------------------|------------------------------|---------------------|
| 2<br>257<br>x 3<br><hr/> 71 | 12<br>257<br>x 3<br><hr/> 71 | 257<br>x 3<br><hr/> |
|-----------------------------|------------------------------|---------------------|

A

|                          |                           |                     |
|--------------------------|---------------------------|---------------------|
| 2<br>2 $\overline{)512}$ | 25<br>2 $\overline{)512}$ | 2 $\overline{)512}$ |
|--------------------------|---------------------------|---------------------|

B

|                           |                          |                      |
|---------------------------|--------------------------|----------------------|
| 4<br>3 $\overline{)1425}$ | 47<br>$\overline{)1425}$ | 3 $\overline{)1425}$ |
|---------------------------|--------------------------|----------------------|

C

(3x3) →

|   |   |    |
|---|---|----|
| 3 | 3 | —  |
| — | 5 | —  |
| — |   | 14 |

|   |   |    |
|---|---|----|
| — | 4 | —  |
| — | 7 | —  |
| — |   | 29 |

|   |   |    |
|---|---|----|
| — | 2 | —  |
| — | 9 | —  |
| — |   | 15 |

|   | A   | B   | C   | D   |
|---|-----|-----|-----|-----|
| E | 2,2 | 2,1 | 3,0 | 481 |
| F | 1,4 | 358 | 3,1 | 366 |
| G | 75  | 256 | 872 | 1,2 |
| H | 3,1 | 796 | 475 | 729 |
| I | 339 | 3,2 | 4,1 | 3,1 |
| J | 771 | 2,3 | 644 | 3,3 |

|   |   |    |
|---|---|----|
| — | 6 | —  |
| — | 5 | —  |
| — |   | 23 |

|   |   |    |
|---|---|----|
| — | 9 | —  |
| — | 4 | —  |
| — |   | 26 |

|   |   |    |
|---|---|----|
| — | 3 | —  |
| — | 8 | —  |
| — |   | 25 |

12 EGGS → 1 DOZ.

| doz.          | eggs |   |
|---------------|------|---|
| 1             |      | A |
| 2             |      | B |
|               | 48   | C |
| $\frac{1}{2}$ |      | D |
| $\frac{1}{3}$ |      | G |
|               | 8    | H |
| $\frac{3}{4}$ |      | I |

C.....4¢

| C  | total  |   |
|----|--------|---|
| 1  | ¢      | C |
| 10 | ¢      | D |
|    | 24¢    | J |
| 16 | ¢      | G |
| 22 | ¢      | I |
|    | 92¢    | J |
|    | \$1.00 | A |

1 LB = 16 OZ.

| LB.            | OZ. |   |
|----------------|-----|---|
| 1              | 16  |   |
|                | 32  | G |
| $\frac{1}{2}$  |     | H |
| $\frac{1}{4}$  |     | C |
| $\frac{1}{8}$  |     | A |
| $\frac{1}{16}$ |     | J |
| $\frac{3}{8}$  |     | D |

1 LB.....48¢

| LBS.           | Total  |   |
|----------------|--------|---|
| 1              | 48¢    |   |
|                | 96¢    | G |
| $\frac{1}{2}$  | ¢      | B |
|                | 12¢    |   |
| $\frac{1}{4}$  | ¢      | E |
| $\frac{2}{3}$  | ¢      | J |
| $2\frac{1}{2}$ | \$     | I |
|                | \$4.80 | D |

1 M = 100cm

| M              | cm  |   |
|----------------|-----|---|
| 1              | 100 |   |
| 5              |     |   |
| 10             |     | J |
| $\frac{1}{2}$  |     | D |
| $\frac{1}{10}$ |     | I |
| $\frac{3}{10}$ |     | G |
|                | 50  | B |
|                | 70  | H |

T = 35¢

| T | total  |   |
|---|--------|---|
| 1 | ¢      |   |
| 2 | ¢      |   |
|   | \$1.40 | G |
|   | \$2.80 | H |

|   | A     | B               | C  | D  | E             | F              |
|---|-------|-----------------|----|----|---------------|----------------|
| G | 2     | 30              | 4  | 50 | 60            | 64             |
| H | 12    | $5\frac{1}{10}$ | 8  | 40 | $\frac{2}{3}$ | $\frac{7}{10}$ |
| I | 25    | 24              | 88 | 10 | 120           | 9              |
| J | 1,000 | 23              | 32 | 6  | 480           | 1              |



$$\begin{array}{r} 100 \\ + 65 \\ \hline \end{array}$$

$$\begin{array}{r} 165 \\ + 15 \\ \hline \end{array}$$

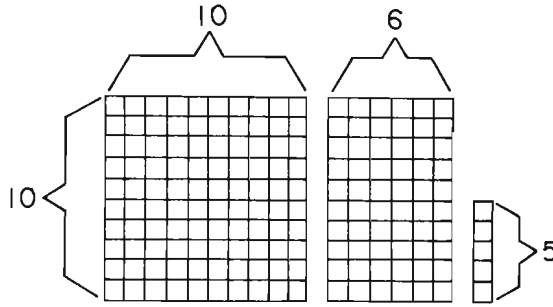

$$\begin{array}{r} 165 \\ - 60 \\ \hline \end{array}$$

$$\begin{array}{r} 165 \\ - 7 \\ \hline \end{array}$$

$$\begin{array}{r} 165 \\ + 300 \\ \hline \end{array}$$

$$\begin{array}{r} 165 \\ + 35 \\ \hline \end{array}$$

$$\begin{array}{r} 160 \\ - 55 \\ \hline \end{array}$$

$$\begin{array}{r} 160 \\ - 65 \\ \hline \end{array}$$

Total -----

$$\begin{array}{r} 165 \\ + 165 \\ \hline \end{array}$$

$$\begin{array}{r} 165 \\ \times 2 \\ \hline \end{array}$$

$$\begin{array}{r} 100 \\ \times 2 \\ \hline \end{array}$$

$$\begin{array}{r} 60 \\ \div 3 \\ \hline \end{array}$$

|  |  |  |  |  |  |  |  |  |  |   |   |   |   |
|--|--|--|--|--|--|--|--|--|--|---|---|---|---|
| $\begin{array}{r} 0 \\ \times 7 \\ \hline \end{array}$ | $\begin{array}{r} 1 \\ \times 7 \\ \hline \end{array}$ | $\begin{array}{r} 2 \\ \times 7 \\ \hline \end{array}$ | $\begin{array}{r} 3 \\ \times 7 \\ \hline \end{array}$ | $\begin{array}{r} 4 \\ \times 7 \\ \hline \end{array}$ | $\begin{array}{r} 5 \\ \times 7 \\ \hline \end{array}$ | $\begin{array}{r} 6 \\ \times 7 \\ \hline \end{array}$ | $\begin{array}{r} 7 \\ \times 7 \\ \hline \end{array}$ | $\begin{array}{r} 8 \\ \times 7 \\ \hline \end{array}$ | $\begin{array}{r} 9 \\ \times 7 \\ \hline \end{array}$ | $\begin{array}{r} 10 \\ \times 7 \\ \hline \end{array}$ | $\begin{array}{r} 11 \\ \times 7 \\ \hline \end{array}$ | $\begin{array}{r} 12 \\ \times 7 \\ \hline \end{array}$ | $\begin{array}{r} 13 \\ \times 7 \\ \hline \end{array}$ |
|--|--|--|--|--|--|--|--|--|--|---|---|---|---|

|  |   |   |
|--|---|---|
| $\begin{array}{r} 5 \\ \times 7 \\ \hline \end{array}$ | $\begin{array}{r} 10 \\ \times 7 \\ \hline \end{array}$ | $\begin{array}{r} 15 \\ \times 7 \\ \hline \end{array}$ |
|--|---|---|

|   |   |   |
|---|---|---|
| $\begin{array}{r} 10 \\ \times 7 \\ \hline \end{array}$ | $\begin{array}{r} 20 \\ \times 7 \\ \hline \end{array}$ | $\begin{array}{r} 30 \\ \times 7 \\ \hline \end{array}$ |
|---|---|---|

|                    |                    |                    |                    |
|--------------------|--------------------|--------------------|--------------------|
| $7 \overline{)10}$ | $7 \overline{)5}$  | $7 \overline{)15}$ | $7 \overline{)30}$ |
| $7 \overline{)63}$ | $7 \overline{)70}$ | $7 \overline{)19}$ | $7 \overline{)20}$ |
| $7 \overline{)35}$ | $7 \overline{)63}$ | $7 \overline{)98}$ | $7 \overline{)16}$ |

|  |   |   |
|--|---|---|
| $\begin{array}{r} 6 \\ \times 7 \\ \hline \end{array}$ | $\begin{array}{r} 20 \\ \times 7 \\ \hline \end{array}$ | $\begin{array}{r} 26 \\ \times 7 \\ \hline \end{array}$ |
|--|---|---|

|  |  |   |
|--|--|---|
| $\begin{array}{r} 4 \\ \times 7 \\ \hline \end{array}$ | $\begin{array}{r} 8 \\ \times 7 \\ \hline \end{array}$ | $\begin{array}{r} 16 \\ \times 7 \\ \hline \end{array}$ |
|--|--|---|

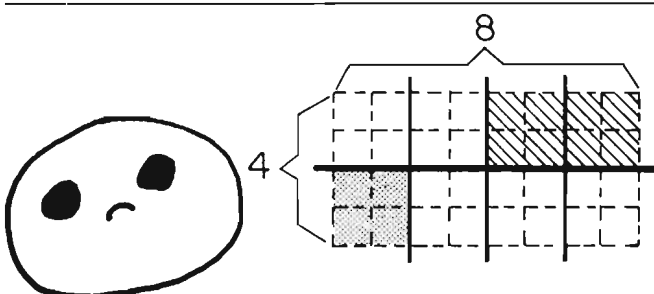

How do you feel?  
¿Cómo se siente?

$$\frac{1}{8} \text{ of } 32 = \text{-----}$$

$$\frac{1}{4} \times 32 = \text{-----}$$

$$\frac{6}{8} \times 32 = \text{-----}$$

$$\frac{3}{4} \times 32 = \text{-----}$$

1 da. = 24 hr.

1 LB. → 32¢

| da.            | hr. |
|----------------|-----|
| 1              | 24  |
| $\frac{1}{2}$  |     |
| $3\frac{1}{2}$ |     |
| $\frac{1}{6}$  |     |
|                | 28  |

| LBS.          | COST |
|---------------|------|
| 1             | 32¢  |
| 3             | ¢    |
| $\frac{1}{2}$ | ¢    |
|               | 8¢   |
|               | 4¢   |

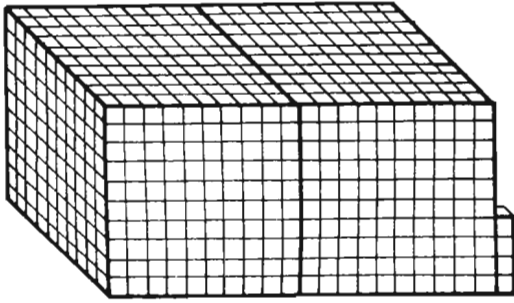

A-----

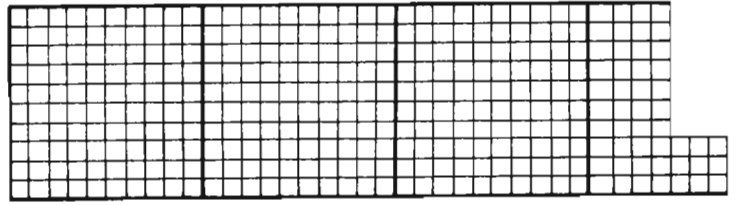

B-----

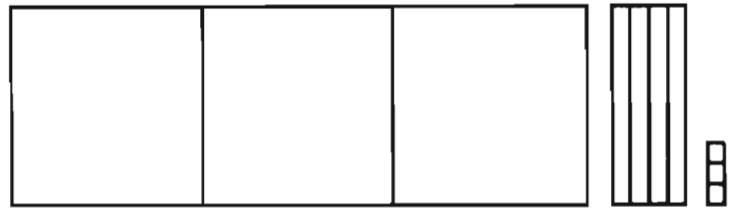
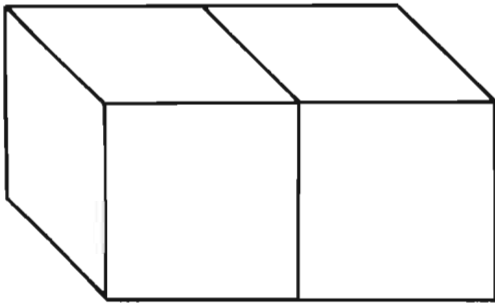

C-----



A 2,343

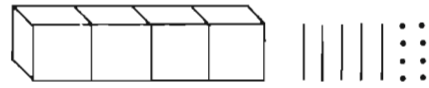

B-----



C-----

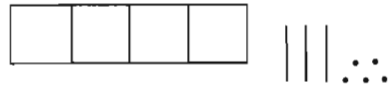

A-----

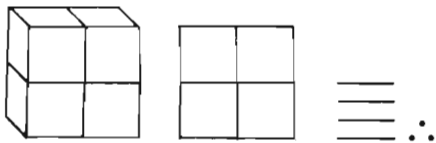

C-----

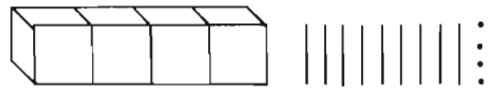

B-----



A-----

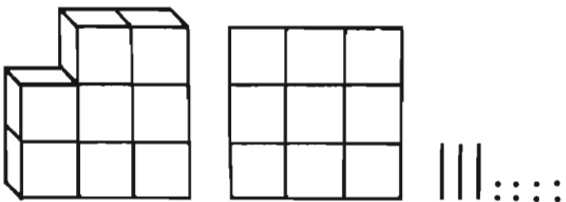

B-----

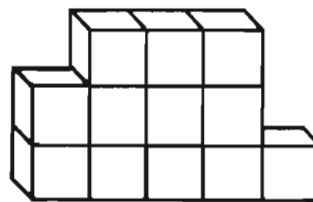

C-----

| A     | B     | C      |
|-------|-------|--------|
| 435   | 4,058 | 12,000 |
| 775   | 8,938 | 864    |
| 2,004 | 396   | 1,725  |
| 915   | 4,094 | 2,343  |
| 2,343 | 944   | 4,443  |
| 458   | 349   | 5,000  |

"HOW MANY?"

"¿CUANTOS?"

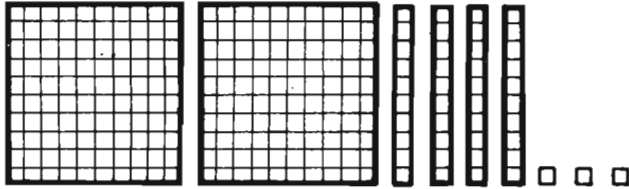

Total \_\_\_\_\_ A

$$\begin{array}{r} 143 \\ +143 \\ \hline \end{array}$$

\_\_\_\_\_ B

$$\begin{array}{r} 243 \\ + 7 \\ \hline \end{array}$$

\_\_\_\_\_ C

$$\begin{array}{r} 243 \\ + 56 \\ \hline \end{array}$$

\_\_\_\_\_ D

$$\begin{array}{r} 243 \\ + 57 \\ \hline \end{array}$$

\_\_\_\_\_ H

$$\begin{array}{r} 243 \\ +190 \\ \hline \end{array}$$

\_\_\_\_\_ I

$$\begin{array}{r} 243 \\ +597 \\ \hline \end{array}$$

\_\_\_\_\_ J

$$\begin{array}{r} 243 \\ +243 \\ \hline \end{array}$$

\_\_\_\_\_ A

$$\begin{array}{r} 486 \\ +243 \\ \hline \end{array}$$

\_\_\_\_\_ B

$$\begin{array}{r} 243 \\ \times 3 \\ \hline \end{array}$$

\_\_\_\_\_ H

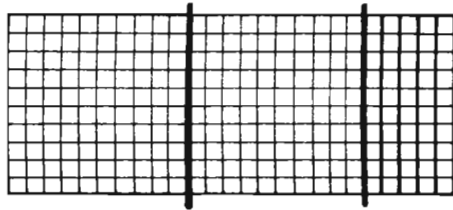

\_\_\_\_\_ F

$$\begin{array}{r} 100 \\ +150 \\ \hline \end{array}$$

\_\_\_\_\_ C

$$\begin{array}{r} 250 \\ + 50 \\ \hline \end{array}$$

\_\_\_\_\_ C

$$\begin{array}{r} 250 \\ + 57 \\ \hline \end{array}$$

\_\_\_\_\_ I

$$\begin{array}{r} 258 \\ +107 \\ \hline \end{array}$$

\_\_\_\_\_ A

$$\begin{array}{r} 258 \\ +157 \\ \hline \end{array}$$

\_\_\_\_\_ B

$$\begin{array}{r} 250 \\ +750 \\ \hline \end{array}$$

\_\_\_\_\_ C

$$\begin{array}{r} 250 \\ \times 2 \\ \hline \end{array}$$

\_\_\_\_\_ J

$$\begin{array}{r} 250 \\ \times 3 \\ \hline \end{array}$$

\_\_\_\_\_ B

$$\begin{array}{r} 250 \\ \times 4 \\ \hline \end{array}$$

\_\_\_\_\_ E

Chain Reactions

Reacción en Cadena



|   | A   | B   | C    |
|---|-----|-----|------|
| D | 365 | 291 | 299  |
| E | 243 | 750 | 1000 |
| F | 486 | 415 | 250  |
| G | 418 | 286 | 512  |
| H | 128 | 729 | 300  |
| I | 433 | 900 | 307  |
| J | 500 | 840 | 800  |

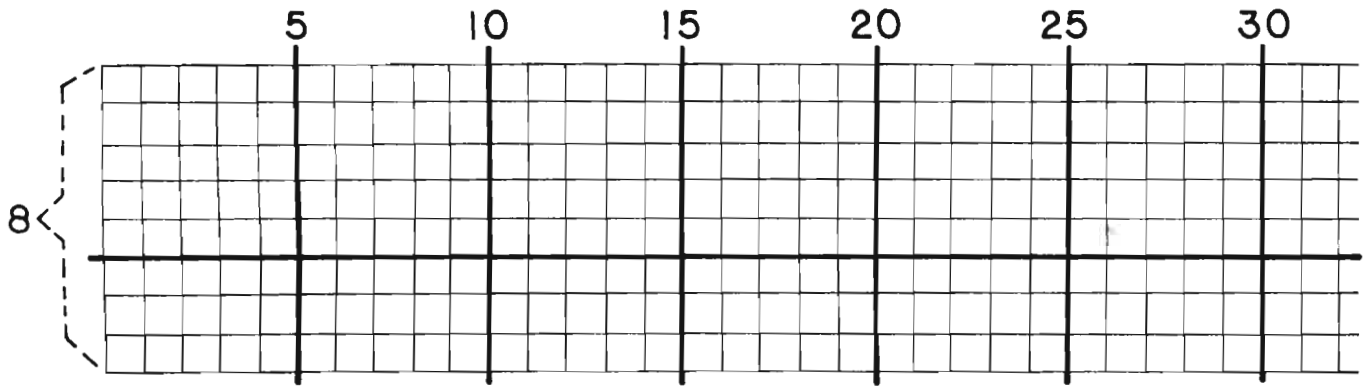

Please complete the tables

Favor de completar las tablas

|            |            |            |            |            |            |            |            |            |            |            |            |            |            |
|------------|------------|------------|------------|------------|------------|------------|------------|------------|------------|------------|------------|------------|------------|
| 0          | 1          | 2          | 3          | 4          | 5          | 6          | 7          | 8          | 9          | 10         | 11         | 12         | 13         |
| $\times 8$ | $\times 8$ | $\times 8$ | $\times 8$ | $\times 8$ | $\times 8$ | $\times 8$ | $\times 8$ | $\times 8$ | $\times 8$ | $\times 8$ | $\times 8$ | $\times 8$ | $\times 8$ |
| A          | B          | C          | D          | E          | F          | G          | H          | I          | J          | K          | A          | B          | C          |

|            |            |            |            |            |            |            |            |            |            |            |            |
|------------|------------|------------|------------|------------|------------|------------|------------|------------|------------|------------|------------|
| 2          | 4          | 8          | 16         | 32         | 5          | 10         | 15         | 20         | 8          | 8          | 8          |
| $\times 8$ | $\times 8$ | $\times 8$ | $\times 8$ | $\times 8$ | $\times 8$ | $\times 8$ | $\times 8$ | $\times 8$ | $\times 7$ | $\times 8$ | $\times 9$ |
| E          | H          | I          | J          |            |            |            |            |            |            |            |            |

|            |            |            |            |            |            |            |            |            |            |            |            |
|------------|------------|------------|------------|------------|------------|------------|------------|------------|------------|------------|------------|
| 13         | 14         | 15         | 16         | 10         | 20         | 30         | 40         | 50         | 60         | 70         | 90         |
| $\times 8$ | $\times 8$ | $\times 8$ | $\times 8$ | $\times 8$ | $\times 8$ | $\times 8$ | $\times 8$ | $\times 8$ | $\times 8$ | $\times 8$ | $\times 8$ |
| C          | D          | D          | E          | F          | H          | D          | A          | K          |            |            |            |

|            |            |            |            |            |            |            |            |            |            |            |            |            |            |
|------------|------------|------------|------------|------------|------------|------------|------------|------------|------------|------------|------------|------------|------------|
| 7          | 10         | 17         | 8          | 8          | 8          | 5          | 20         | 25         | 8          | 30         | 38         | 11         | 22         |
| $\times 8$ | $\times 8$ | $\times 8$ | $\times 4$ | $\times 5$ | $\times 9$ | $\times 8$ | $\times 8$ | $\times 8$ | $\times 8$ | $\times 8$ | $\times 8$ | $\times 8$ | $\times 8$ |
| A          | J          | D          | C          | A          | K          |            |            |            |            |            |            |            |            |

Please extend the patterns as indicated

(Favor de extender las muestras.)

- 2 . 7 . 12 . 17 . . . . . 47 .
- 6 . 9 . 12 . 15 . . . . . 33 .
- 52 . 48 . 44 . . . . . 16 .
- 104 . 96 . 88 . . . . . 32 .
- 8 . . . . . 24 . . . . . 40 . . . . . 80 .

|   | A   | B   | C   | D   |
|---|-----|-----|-----|-----|
| E | 304 | 32  | 240 | 128 |
| F | 88  | 320 | 16  | 40  |
| G | 48  | 8   | 104 | 480 |
| H | 400 | 256 | 56  | 200 |
| I | 560 | 64  | 120 | 24  |
| J | 136 | 96  | 72  | 160 |
| K | 0   | 176 | 80  | 720 |

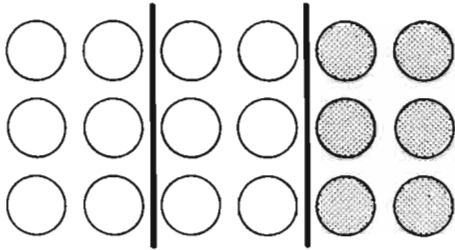

Total =       
A

$\frac{1}{3}$  of       
A =       
B

$\frac{2}{3}$  of       
A =       
C

$\frac{3}{3}$  of       
A =       
J

$\frac{1}{3} + \frac{1}{3} =$        
D

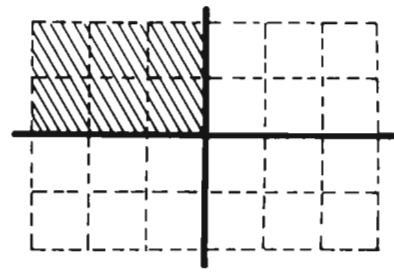

=       
B

$\frac{1}{4}$  of       
B =       
F

$\frac{3}{4} \times$        
B =       
A

$\frac{1}{2} \times$        
B =       
H

$\frac{1}{2} + \frac{1}{4} =$        
D

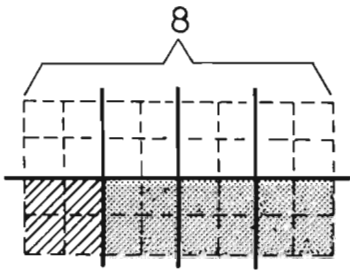

=       
G

$\frac{1}{8}$  of       
G =       
E

$\frac{3}{8} \times$        
G =       
C

$\frac{1}{2} \times$        
G =       
B

$\frac{1}{8} + \frac{3}{8} =$        
D

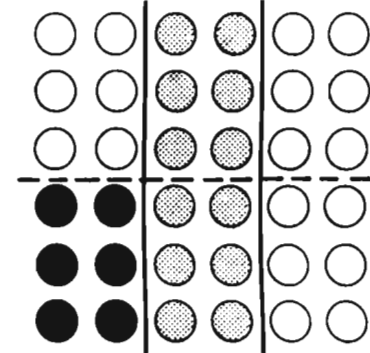

=       
C

$\frac{1}{6} \times$        
C =       
B

$\frac{1}{3} \times$        
C =       
H

$\frac{1}{2} \times$        
C =       
A

$\frac{1}{6} + \frac{1}{3} =$        
D

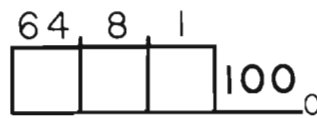
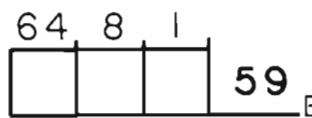
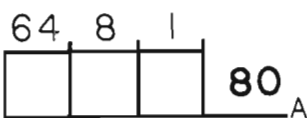
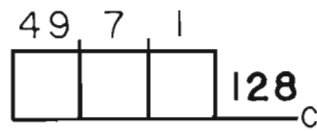
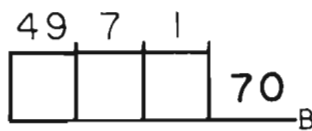
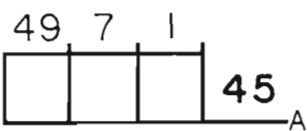
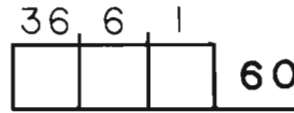
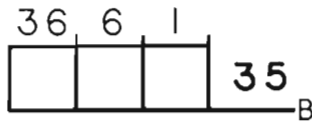
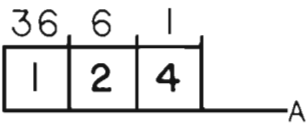

|   | A    | B    | C    | D                          |
|---|------|------|------|----------------------------|
| E | 2,13 | 0,73 | 4    | $\frac{3}{4}$              |
| F | 52   | 6    | 24,2 | $\frac{5}{6}$              |
| G | 32   | 0,55 | 36   | $\frac{2}{3}$              |
| H | 0,63 | 16   | 12   | $\frac{1}{4}$              |
| I | 1,20 | 24   | 14,4 | $\frac{1}{2}, \frac{4}{8}$ |
| J | 18   | 1,30 | 14,4 | $\frac{1}{2}, \frac{3}{6}$ |

"HOW MANY?"

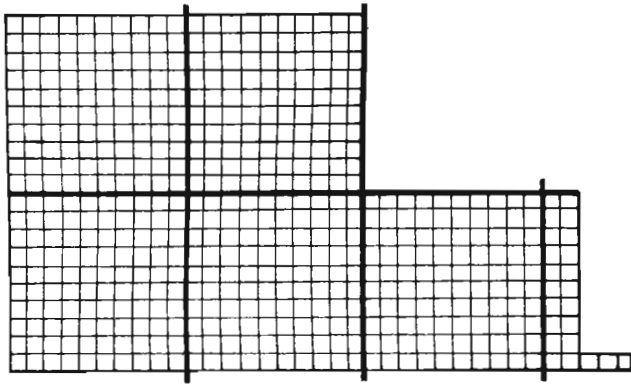

Total -----A

"¿CUANTOS?"

$$\begin{array}{r} 630 \\ - 7 \\ \hline \end{array}$$

-----B

$$\begin{array}{r} 523 \\ - 107 \\ \hline \end{array}$$

-----B

$$\begin{array}{r} 523 \\ - 416 \\ \hline \end{array}$$

-----

$$\begin{array}{r} 523 \\ - 24 \\ \hline \end{array}$$

-----C

$$\begin{array}{r} 523 \\ - 227 \\ \hline \end{array}$$

-----C

$$\begin{array}{r} 523 \\ - 296 \\ \hline \end{array}$$

-----C

$$\begin{array}{r} 523 \\ - 34 \\ \hline \end{array}$$

-----A

$$\begin{array}{r} 523 \\ - 184 \\ \hline \end{array}$$

-----A

$$\begin{array}{r} 523 \\ - 339 \\ \hline \end{array}$$

-----A

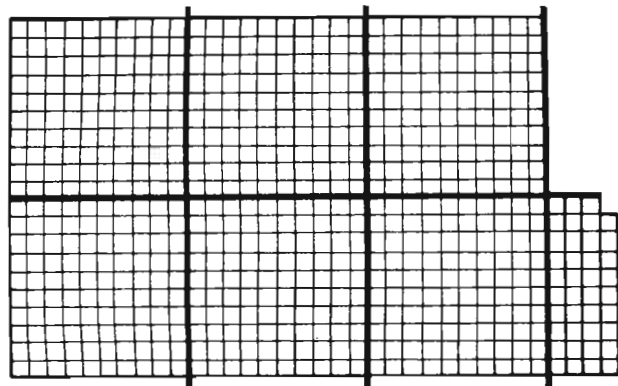

-----D

$$\begin{array}{r} 640 \\ - 21 \\ \hline \end{array}$$

-----E

$$\begin{array}{r} 439 \\ - 150 \\ \hline \end{array}$$

-----A

$$\begin{array}{r} 639 \\ + 639 \\ \hline \end{array}$$

-----

$$\begin{array}{r} 639 \\ - 40 \\ \hline \end{array}$$

-----

$$\begin{array}{r} 929 \\ - 238 \\ \hline \end{array}$$

-----B

$$\begin{array}{r} 639 \\ \times 2 \\ \hline \end{array}$$

-----I

$$\begin{array}{r} 639 \\ - 447 \\ \hline \end{array}$$

-----G

$$\begin{array}{r} 3639 \\ - 740 \\ \hline \end{array}$$

-----C

$$\begin{array}{r} 639 \\ \div 3 \\ \hline \end{array}$$

-----J

Multiplication  
and  
Division

(12 × 2)

$$\square \begin{array}{r} 24 \\ - 6 \\ \hline \end{array} \bigcirc$$

(12 ÷ 2)

$$\square \begin{array}{r} 32 \\ - 2 \\ \hline \end{array} \bigcirc$$

$$\square \begin{array}{r} 45 \\ - 5 \\ \hline \end{array} \bigcirc$$

Multiplicar  
y  
Dividir

$$\square \begin{array}{r} 27 \\ - 3 \\ \hline \end{array} \bigcirc$$

$$\square \begin{array}{r} 36 \\ - 4 \\ \hline \end{array} \bigcirc$$

$$\square \begin{array}{r} 28 \\ - 7 \\ \hline \end{array} \bigcirc$$

$$\square \begin{array}{r} 18 \\ - 2 \\ \hline \end{array} \bigcirc$$

$$\square \begin{array}{r} 50 \\ - 2 \\ \hline \end{array} \bigcirc$$

$$\square \begin{array}{r} 80 \\ - 5 \\ \hline \end{array} \bigcirc \text{ B}$$

|   | A     | B   | C     |
|---|-------|-----|-------|
| D | 339   | 204 | 639   |
| E | 619   | 623 | 296   |
| F | 289   | 416 | 399   |
| G | 523   | 192 | 227   |
| H | 184   | 691 | 499   |
| I | 1,278 | 8,4 | 105   |
| J | 489   | 213 | 2,899 |

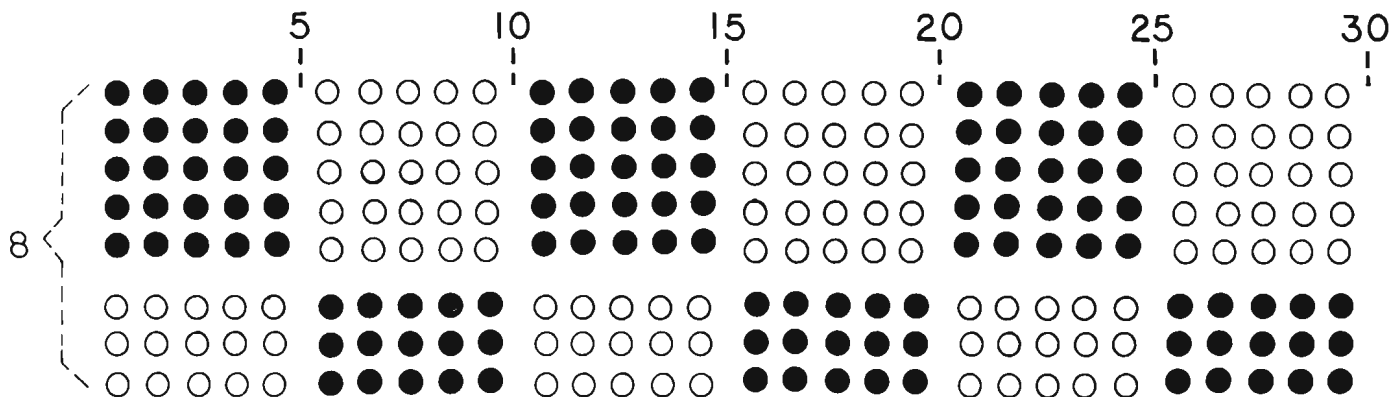

|                    |                    |                    |                    |                    |                    |                    |                    |                    |
|--------------------|--------------------|--------------------|--------------------|--------------------|--------------------|--------------------|--------------------|--------------------|
| $8 \overline{) 1}$ | $8 \overline{) 2}$ | $8 \overline{) 3}$ | $8 \overline{) 4}$ | $8 \overline{) 5}$ | $8 \overline{) 6}$ | $8 \overline{) 7}$ | $8 \overline{) 8}$ | $8 \overline{) 9}$ |
| A                  | B                  | C                  | D                  | E                  | F                  | G                  | H                  | I                  |

|                    |                    |                     |                     |
|--------------------|--------------------|---------------------|---------------------|
| $8 \overline{) 0}$ | $8 \overline{) 5}$ | $8 \overline{) 10}$ | $8 \overline{) 15}$ |
|--------------------|--------------------|---------------------|---------------------|

|                    |                    |                    |                     |
|--------------------|--------------------|--------------------|---------------------|
| $8 \overline{) 3}$ | $8 \overline{) 6}$ | $8 \overline{) 9}$ | $8 \overline{) 12}$ |
| B                  |                    |                    |                     |

|                     |                      |                      |                      |
|---------------------|----------------------|----------------------|----------------------|
| $8 \overline{) 80}$ | $8 \overline{) 160}$ | $8 \overline{) 240}$ | $8 \overline{) 400}$ |
| A                   | E                    | A                    |                      |

|                      |                     |                      |                      |
|----------------------|---------------------|----------------------|----------------------|
| $8 \overline{) 320}$ | $8 \overline{) 24}$ | $8 \overline{) 344}$ | $8 \overline{) 688}$ |
| E                    | F                   | A                    |                      |

|                     |                    |                     |                      |
|---------------------|--------------------|---------------------|----------------------|
| $8 \overline{) 20}$ | $8 \overline{) 9}$ | $8 \overline{) 29}$ | $8 \overline{) 464}$ |
| D                   | J                  |                     |                      |

|                    |                    |                    |                    |
|--------------------|--------------------|--------------------|--------------------|
| $8 \overline{) 8}$ | $9 \overline{) 8}$ | $7 \overline{) 8}$ | $6 \overline{) 8}$ |
|--------------------|--------------------|--------------------|--------------------|

|                     |                     |                      |                    |                    |                    |                      |                      |                     |
|---------------------|---------------------|----------------------|--------------------|--------------------|--------------------|----------------------|----------------------|---------------------|
| $8 \overline{) 80}$ | $8 \overline{) 56}$ | $8 \overline{) 136}$ | $9 \overline{) 8}$ | $7 \overline{) 8}$ | $6 \overline{) 8}$ | $8 \overline{) 160}$ | $8 \overline{) 184}$ | $8 \overline{) 46}$ |
| A                   |                     |                      |                    |                    |                    | C                    |                      | K                   |

$$\begin{array}{r} 2 \ 1 \ 3 \\ 2 \ 1 \ 3 \\ 2 \ 1 \ 3 \\ 2 \ 1 \ 3 \\ + 2 \ 1 \ 3 \\ \hline \end{array} \quad G$$

$$\begin{array}{r} 3 \ 2 \ 1 \\ 3 \ 2 \ 1 \\ 3 \ 2 \ 1 \\ 3 \ 2 \ 1 \\ + 3 \ 2 \ 1 \\ \hline \end{array} \quad C$$

$$\begin{array}{r} 1 \ 2 \ 3 \\ 1 \ 2 \ 3 \\ 1 \ 2 \ 3 \\ 1 \ 2 \ 3 \\ + 1 \ 2 \ 3 \\ \hline \end{array} \quad H$$

$$\begin{array}{r} 2 \ 0 \ 3 \\ 2 \ 0 \ 3 \\ 2 \ 0 \ 3 \\ 2 \ 0 \ 3 \\ + 2 \ 0 \ 3 \\ \hline \end{array} \quad E$$

|   | A   | B  | C    | D   |
|---|-----|----|------|-----|
| E | 120 | 30 | 1015 | 40  |
| F | 120 | 48 | 24   | 43  |
| G | 8   | 96 | 1065 | 56  |
| H | 17  | 16 | 64   | 615 |
| I | 20  | 72 | 1605 | 32  |
| J | 86  | 58 | 0    | 232 |
| K | 50  | 80 | 23   | 368 |

Please remember that this is one of several shortcuts to correct answers.

Favor de recordar que este es uno de varios caminos cortos para obtener respuestas correctas.

$$\begin{array}{r} 2 \\ 16 \\ 13 \\ 14 \\ + 27 \\ \hline 0 \end{array} \quad \begin{array}{r} 16 \\ 13 \\ 14 \\ + 17 \\ \hline \end{array}$$

A

$$\begin{array}{r} 2 \\ 152 \\ 152 \\ 152 \\ + 152 \\ \hline 08 \end{array} \quad \begin{array}{r} 152 \\ 152 \\ 152 \\ + 152 \\ \hline \end{array}$$

B

$$\begin{array}{r} 2 \\ 437 \\ 437 \\ 437 \\ + 437 \\ \hline 8 \end{array} \quad \begin{array}{r} 12 \\ 437 \\ 437 \\ 437 \\ + 437 \\ \hline 8 \end{array} \quad \begin{array}{r} 437 \\ 437 \\ 437 \\ + 437 \\ \hline \end{array}$$

C

$$\begin{array}{r} 3 \\ 475 \\ - 192 \\ \hline \end{array} \quad \begin{array}{r} 475 \\ - 192 \\ \hline \end{array}$$

D

$$\begin{array}{r} 6 \\ 475 \\ - 198 \\ \hline \end{array} \quad \begin{array}{r} 36 \\ 475 \\ - 198 \\ \hline \end{array} \quad \begin{array}{r} 475 \\ - 198 \\ \hline \end{array}$$

E

$$\begin{array}{r} 4 \\ 1253 \\ - 789 \\ \hline \end{array} \quad \begin{array}{r} 14 \\ 1253 \\ - 789 \\ \hline \end{array} \quad \begin{array}{r} 1253 \\ - 789 \\ \hline \end{array}$$

F

$$\begin{array}{r} 2 \\ 431 \\ \times 9 \\ \hline \end{array} \quad \begin{array}{r} 431 \\ \times 9 \\ \hline \end{array}$$

G

$$\begin{array}{r} 607 \\ \times 5 \\ \hline \end{array} \quad \begin{array}{r} 607 \\ \times 5 \\ \hline \end{array}$$

H

$$\begin{array}{r} 4 \\ 138 \\ \times 5 \\ \hline \end{array} \quad \begin{array}{r} 138 \\ \times 5 \\ \hline \end{array} \quad \begin{array}{r} 138 \\ \times 5 \\ \hline \end{array}$$

I

$$\begin{array}{r} 5 \\ 6 \overline{)3276} \end{array} \quad \begin{array}{r} 54 \\ 6 \overline{)3276} \end{array} \quad \begin{array}{r} 6 \overline{)3276} \end{array}$$

J

$$\begin{array}{r} 2 \\ 9 \overline{)2088} \end{array} \quad \begin{array}{r} 2 \\ 9 \overline{)2088} \end{array} \quad \begin{array}{r} 9 \overline{)2088} \end{array}$$

A

|         |  |  |  |
|---------|--|--|--|
|         | Sumar<br>-----<br>y<br>Restar                    | Addition<br>and<br>Subtraction                   |  |
| (9+7) ↘ | $\square \text{---} 9 \text{---} \text{---} 7$   | $\square \text{---} 19 \text{---} \text{---} 3$  | $\square \text{---} 33 \text{---} \text{---} 7$  |
| (9-7) ↙ | $\square \text{---} 27 \text{---} \text{---} 11$ | $\square \text{---} 31 \text{---} \text{---} 3$  | $\square \text{---} 40 \text{---} \text{---} 12$ |
|         | $\square \text{---} 51 \text{---} \text{---} 3$  | $\square \text{---} 51 \text{---} \text{---} 13$ | $\square \text{---} 51 \text{---} \text{---} 27$ |

|   | A   | B     | C     | D     |
|---|-----|-------|-------|-------|
| E | 40  | 952   | 277   | 125   |
| F | 60  | 1,371 | 413   | 464   |
| G | 839 | 3,879 | 1,748 | 53    |
| H | 602 | 608   | 984   | 3,035 |
| I | 26  | 690   | 75    | 283   |
| J | 232 | 18    | 546   | 30    |



1 HOUR = 60 minutes

| HOURS          | minutes |   |
|----------------|---------|---|
| 1              |         | A |
| 2              |         | B |
| 3              |         | C |
| $\frac{1}{2}$  |         | D |
| $\frac{3}{4}$  |         | E |
| $1\frac{1}{2}$ |         | F |
| $2\frac{1}{3}$ |         | G |

72¢ a yard

| yards          | price  |   |
|----------------|--------|---|
| 1              | ¢      | H |
| 2              | \$     | I |
|                | \$2.88 | J |
| $\frac{1}{2}$  | ¢      | K |
|                | 18¢    | A |
| $\frac{3}{4}$  | ¢      | B |
| $1\frac{1}{2}$ | \$     | C |

$\frac{1}{2}$  OFF

| regular | sale   |   |
|---------|--------|---|
| 50¢     | ¢      | D |
| \$1.00  | ¢      | E |
| ¢       | 21¢    | F |
| \$3.00  | \$     | G |
| 90¢     | ¢      | E |
| \$      | 75¢    | E |
| \$      | \$8.50 | F |

\$1 = 10 (10¢)

| DOLLARS        | DIMES |   |
|----------------|-------|---|
| 1              |       | G |
|                | 20    | C |
| 5              |       | H |
| $\frac{1}{2}$  |       | E |
| $\frac{1}{5}$  |       | J |
| $\frac{1}{10}$ |       | A |
|                | 15    | G |
| $3\frac{2}{5}$ |       | D |

120 miles/hour

| HOURS          | miles |   |
|----------------|-------|---|
| 1              | 120   |   |
| 2              |       |   |
| $\frac{1}{2}$  |       | A |
| $3\frac{1}{2}$ |       |   |
| $\frac{1}{4}$  |       | D |
| $2\frac{1}{4}$ |       | B |
| $1\frac{3}{4}$ |       | C |
|                | 40    | A |

1 GALLON  
4 QUARTS

| GALS. | QTS.          |   |
|-------|---------------|---|
| 2     |               |   |
|       | 2             | E |
|       | 1             | A |
|       | $\frac{1}{2}$ | G |

|   | A             | B              | C    | D   | E             | F     |
|---|---------------|----------------|------|-----|---------------|-------|
| G | $\frac{1}{8}$ | $1\frac{1}{2}$ | 180  | 10  | 1,50          | 140   |
| H | $\frac{1}{3}$ | 72             | 210  | 30  | 50            | 17,00 |
| I | 60            | 270            | 1,08 | 144 | $\frac{1}{2}$ | 90    |
| J | $\frac{1}{4}$ | 120            | 2    | 34  | 45            | 4     |
| K | 1             | 54             | 36   | 25  | 5             | 42    |

**Addition**  
Sumar

$$\begin{array}{r} 155 \\ + 15 \\ \hline \end{array} \quad \begin{array}{r} 155 \\ + 45 \\ \hline \end{array}$$

$$\begin{array}{r} 155 \\ + 87 \\ \hline \end{array} \quad \begin{array}{r} 355 \\ + 355 \\ \hline \end{array}$$

$$\begin{array}{r} 155 \\ \times 2 \\ \hline \end{array} \quad \begin{array}{r} 355 \\ \times 2 \\ \hline \end{array}$$

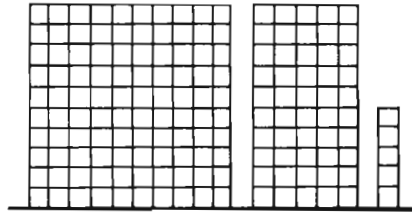

Total 155

**Subtraction**  
Restar

$$\begin{array}{r} 155 \\ - 9 \\ \hline \end{array} \quad \begin{array}{r} 155 \\ - 59 \\ \hline \end{array}$$

$$\begin{array}{r} 150 \\ - 80 \\ \hline \end{array} \quad \begin{array}{r} 150 \\ - 86 \\ \hline \end{array}$$

$$\begin{array}{r} 647 \\ - 155 \\ \hline \end{array} \quad \begin{array}{r} 626 \\ - 155 \\ \hline \end{array}$$

|            |            |            |            |            |            |            |            |            |            |            |            |            |            |
|------------|------------|------------|------------|------------|------------|------------|------------|------------|------------|------------|------------|------------|------------|
| 0          | 1          | 2          | 3          | 4          | 5          | 6          | 7          | 8          | 9          | 10         | 11         | 12         | 13         |
| $\times 8$ | $\times 8$ | $\times 8$ | $\times 8$ | $\times 8$ | $\times 8$ | $\times 8$ | $\times 8$ | $\times 8$ | $\times 8$ | $\times 8$ | $\times 8$ | $\times 8$ | $\times 8$ |

|            |            |            |
|------------|------------|------------|
| 7          | 10         | 17         |
| $\times 8$ | $\times 8$ | $\times 8$ |

|            |            |            |
|------------|------------|------------|
| 8          | 16         | 32         |
| $\times 8$ | $\times 8$ | $\times 8$ |

|            |            |            |
|------------|------------|------------|
| 20         | 30         | 40         |
| $\times 8$ | $\times 8$ | $\times 8$ |

|            |            |            |
|------------|------------|------------|
| 30         | 9          | 39         |
| $\times 8$ | $\times 8$ | $\times 8$ |

|                     |                     |                     |                     |
|---------------------|---------------------|---------------------|---------------------|
| $8 \overline{)160}$ | $8 \overline{)40}$  | $8 \overline{)200}$ | $8 \overline{)400}$ |
| $8 \overline{)56}$  | $8 \overline{)112}$ | $8 \overline{)224}$ | $8 \overline{)448}$ |
| $8 \overline{)320}$ | $8 \overline{)24}$  | $8 \overline{)344}$ | $8 \overline{)688}$ |



How do you feel?  
¿Cómo se siente?

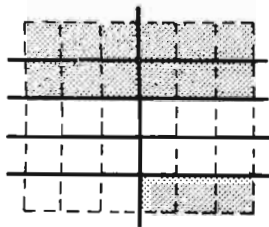

Total

$$\frac{1}{10} \text{ of } 30 = \text{-----}$$

$$\frac{2}{5} \times 30 = \text{-----}$$

$$\frac{1}{2} \times 30 = \text{-----}$$

$$\frac{2}{5} + \frac{1}{10} = \text{-----}$$

1 METER  
= 10 DECIMETERS

$\frac{1}{2}$  OFF

| M               | dm |
|-----------------|----|
| 1               | 10 |
| 10              |    |
| $\frac{1}{2}$   |    |
| $\frac{1}{10}$  |    |
| $1\frac{3}{10}$ |    |

| P      | $\frac{1}{2}$ P |
|--------|-----------------|
| 30¢    | 15¢             |
| \$1.50 | ¢               |
| \$     | \$2.50          |
| 72¢    | ¢               |
| \$     | \$7.25          |

"HOW MANY?"

"¿CUANTOS?"

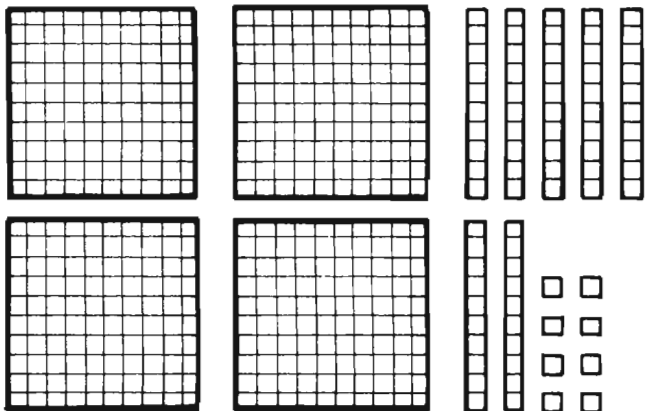

Total -----A

$$\begin{array}{r} 478 \\ + 2 \\ \hline \end{array}$$

-----B

$$\begin{array}{r} 478 \\ - 77 \\ \hline \end{array}$$

-----E

$$\begin{array}{r} 245 \\ + 233 \\ \hline \end{array}$$

-----D

$$\begin{array}{r} 478 \\ + 30 \\ \hline \end{array}$$

-----C

$$\begin{array}{r} 478 \\ - 140 \\ \hline \end{array}$$

-----F

$$\begin{array}{r} 245 \\ + 7 \\ \hline \end{array}$$

-----E

$$\begin{array}{r} 475 \\ + 130 \\ \hline \end{array}$$

-----D

$$\begin{array}{r} 478 \\ - 9 \\ \hline \end{array}$$

-----G

$$\begin{array}{r} 248 \\ + 60 \\ \hline \end{array}$$

-----F

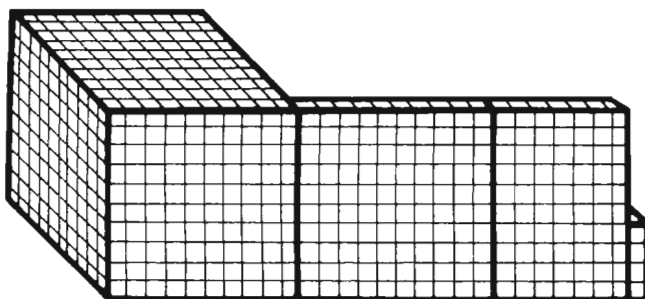

Total -----A

$$\begin{array}{r} 174 \\ + 8 \\ \hline \end{array}$$

-----B

$$\begin{array}{r} 1,174 \\ + 1,000 \\ \hline \end{array}$$

-----A

$$\begin{array}{r} 1,174 \\ - 174 \\ \hline \end{array}$$

-----A

$$\begin{array}{r} 174 \\ + 18 \\ \hline \end{array}$$

-----C

$$\begin{array}{r} 1,174 \\ + 1,315 \\ \hline \end{array}$$

-----B

$$\begin{array}{r} 1,174 \\ - 175 \\ \hline \end{array}$$

-----B

$$\begin{array}{r} 174 \\ + 28 \\ \hline \end{array}$$

-----D

$$\begin{array}{r} 1,174 \\ + 900 \\ \hline \end{array}$$

-----C

$$\begin{array}{r} 1,174 \\ - 1,008 \\ \hline \end{array}$$

-----C

Chain Reactions

Reacción en Cadena

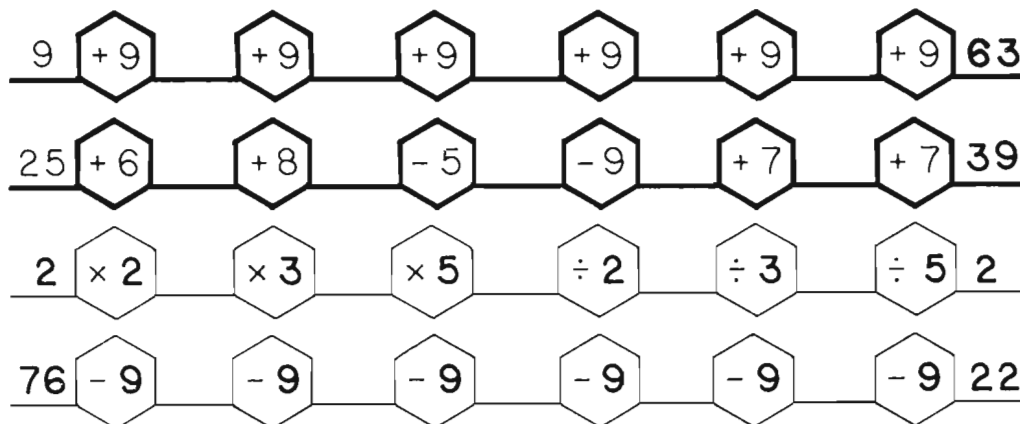

|   | A     | B     | C     |
|---|-------|-------|-------|
| D | 605   | 202   | 478   |
| E | 252   | 480   | 401   |
| F | 1,174 | 338   | 308   |
| G | 984   | 469   | 508   |
| H | 1,000 | 182   | 166   |
| I | 478   | 2,489 | 192   |
| J | 2,174 | 999   | 2,074 |

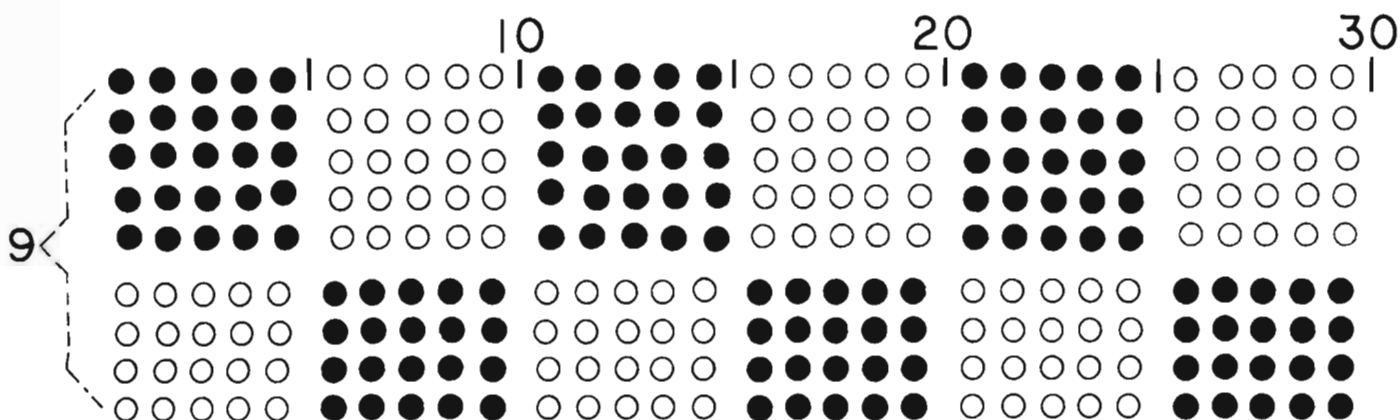

|            |            |            |            |            |            |            |            |            |            |            |            |            |            |
|------------|------------|------------|------------|------------|------------|------------|------------|------------|------------|------------|------------|------------|------------|
| 0          | 1          | 2          | 3          | 4          | 5          | 6          | 7          | 8          | 9          | 10         | 11         | 12         | 13         |
| $\times 9$ | $\times 9$ | $\times 9$ | $\times 9$ | $\times 9$ | $\times 9$ | $\times 9$ | $\times 9$ | $\times 9$ | $\times 9$ | $\times 9$ | $\times 9$ | $\times 9$ | $\times 9$ |

A B C D E F G H I J K A B C

|            |            |            |            |            |
|------------|------------|------------|------------|------------|
| 5          | 10         | 15         | 30         | 60         |
| $\times 9$ | $\times 9$ | $\times 9$ | $\times 9$ | $\times 9$ |

D E

|            |            |            |            |
|------------|------------|------------|------------|
| 4          | 20         | 24         | 48         |
| $\times 9$ | $\times 9$ | $\times 9$ | $\times 9$ |

F G A

|            |            |            |
|------------|------------|------------|
| 9          | 40         | 49         |
| $\times 9$ | $\times 9$ | $\times 9$ |

B C

|            |            |            |            |
|------------|------------|------------|------------|
| 8          | 9          | 17         | 34         |
| $\times 9$ | $\times 9$ | $\times 9$ | $\times 9$ |

A B

|            |            |            |            |
|------------|------------|------------|------------|
| 3          | 6          | 12         | 24         |
| $\times 9$ | $\times 9$ | $\times 9$ | $\times 9$ |

C

|            |            |            |            |
|------------|------------|------------|------------|
| 8          | 10         | 18         | 30         |
| $\times 9$ | $\times 9$ | $\times 9$ | $\times 9$ |

A D

|            |            |            |            |            |            |            |            |            |            |            |            |            |            |
|------------|------------|------------|------------|------------|------------|------------|------------|------------|------------|------------|------------|------------|------------|
| 14         | 15         | 16         | 17         | 50         | 70         | 80         | 90         | 100        | 4          | 30         | 34         | 7          | 17         |
| $\times 9$ | $\times 9$ | $\times 9$ | $\times 9$ | $\times 9$ | $\times 9$ | $\times 9$ | $\times 9$ | $\times 9$ | $\times 9$ | $\times 9$ | $\times 9$ | $\times 9$ | $\times 9$ |

A

E

A

D

H

A

**TWO-WAY Chain Reactions**

**Reacción en cadena en DOS MANERAS**

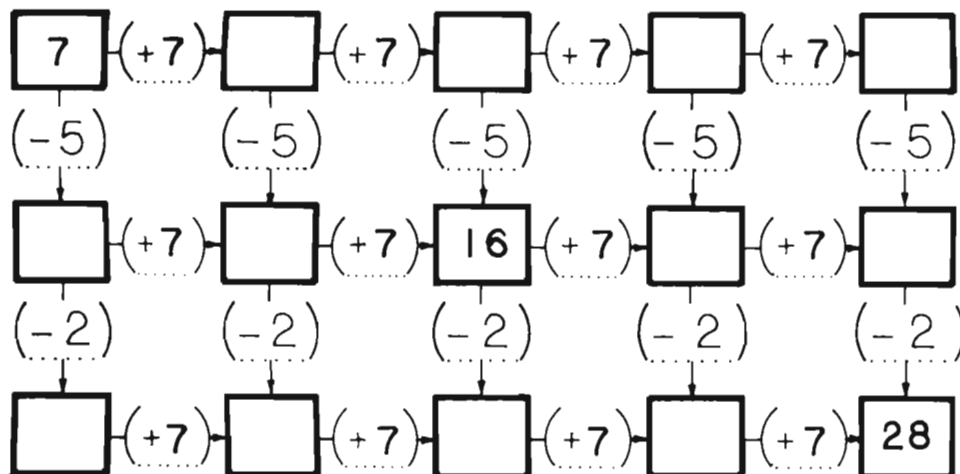

|   | A   | B   | C   | D   |
|---|-----|-----|-----|-----|
| E | 144 | 36  | 450 | 540 |
| F | 162 | 180 | 18  | 45  |
| G | 810 | 9   | 216 | 54  |
| H | 0   | 306 | 63  | 900 |
| I | 432 | 72  | 441 | 27  |
| J | 99  | 360 | 81  | 270 |
| K | 153 | 108 | 117 | 90  |

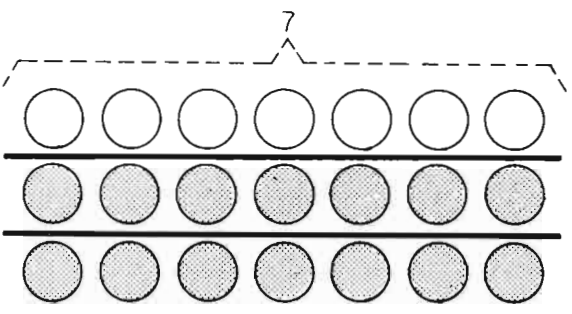

Total =      A

$\frac{2}{3}$  of      A =      B       $\frac{1}{3}$  of      A =      C

$\frac{3}{3}$  of      A =      F       $\frac{3}{3} - \frac{2}{3} =$       D

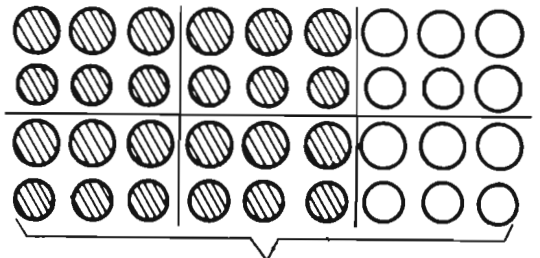

=      B

$\frac{2}{3}$  of      B =      C       $\frac{1}{6} \times$       B =      H

$\frac{1}{2} \times$       B =      J       $\frac{2}{3} - \frac{1}{6} =$       D

---

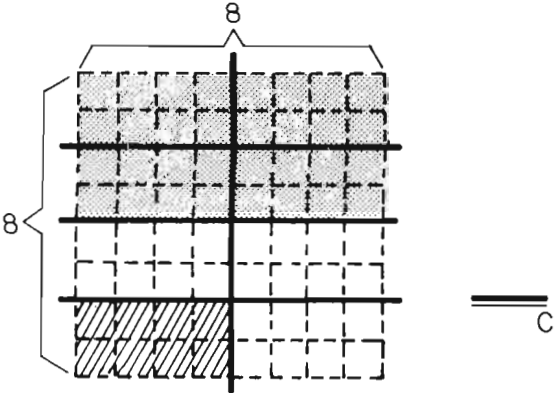

=      C

$\frac{1}{8}$  of      C =      A       $\frac{1}{2} \times$       C =      B

$\frac{3}{8} \times$       C =      H       $\frac{1}{2} - \frac{1}{8} =$       D

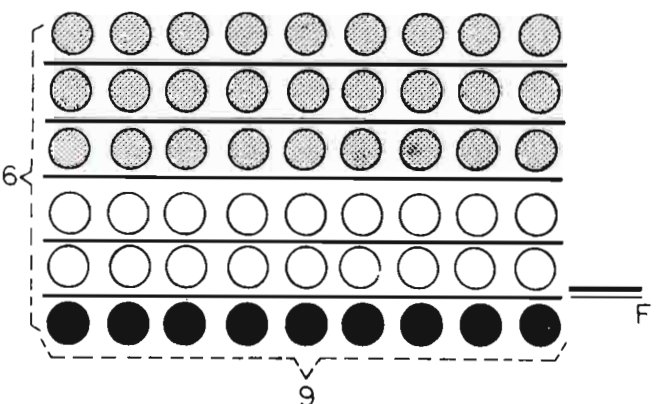

=      F

$\frac{1}{6} \times$       F =      E       $\frac{1}{3} \times$       F =      C

$\frac{1}{2} \times$       F =      A       $\frac{1}{6} + \frac{1}{3} =$       D

DOMINO PUZZLES

ROMPECABEZAS DE DOMINOS

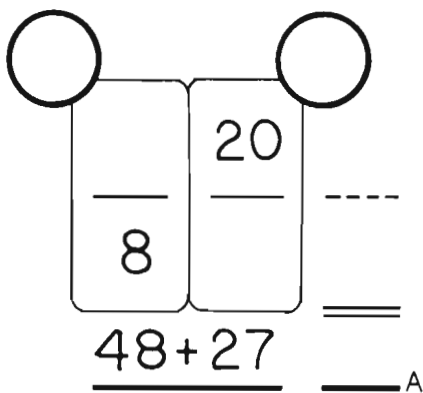

48 + 27 =      A

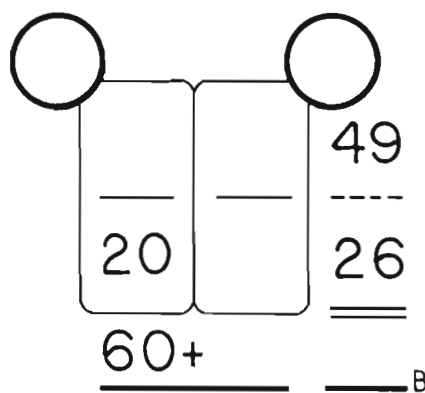

60 +      B

|   | A  | B  | C  | D                          |
|---|----|----|----|----------------------------|
| E | 18 | 9  |    | $\frac{1}{9}$              |
| F | 21 | 75 | 54 | $\frac{2}{5}$              |
| G | 27 | 36 | 7  | $\frac{1}{3}$              |
| H | 6  | 42 | 24 | $\frac{3}{4}$              |
| I | 75 | 14 | 64 | $\frac{1}{2}, \frac{3}{6}$ |
| J | 8  | 32 | 18 | $\frac{3}{8}$              |

"HOW MANY?"

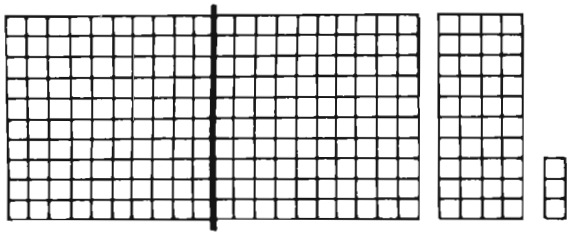

Total -----A

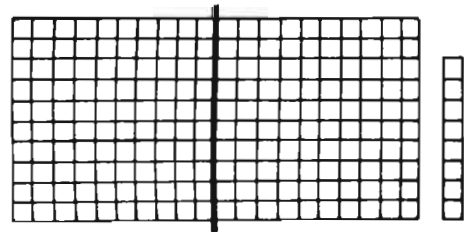

Total -----A

"¿CUANTOS?"

$$\begin{array}{r} 150 \\ - 6 \\ \hline \end{array}$$

-----B

$$\begin{array}{r} 243 \\ - 117 \\ \hline \end{array}$$

-----E

$$\begin{array}{r} 373 \\ - 183 \\ \hline \end{array}$$

-----H

$$\begin{array}{r} 200 \\ - 82 \\ \hline \end{array}$$

-----C

$$\begin{array}{r} 1243 \\ - 52 \\ \hline \end{array}$$

-----F

$$\begin{array}{r} 373 \\ - 249 \\ \hline \end{array}$$

-----I

$$\begin{array}{r} 240 \\ - 90 \\ \hline \end{array}$$

-----D

$$\begin{array}{r} 743 \\ - 181 \\ \hline \end{array}$$

-----G

$$\begin{array}{r} 783 \\ - 194 \\ \hline \end{array}$$

-----J

$$\begin{array}{r} 150 \\ + 58 \\ \hline \end{array}$$

-----H

$$\begin{array}{r} 705 \\ - 208 \\ \hline \end{array}$$

-----D

$$\begin{array}{r} 208 \\ \div 2 \\ \hline \end{array}$$

-----B

$$\begin{array}{r} 208 \\ - 19 \\ \hline \end{array}$$

-----A

$$\begin{array}{r} 208 \\ \times 2 \\ \hline \end{array}$$

-----E

$$\begin{array}{r} 104 \\ \div 2 \\ \hline \end{array}$$

-----C

$$\begin{array}{r} 807 \\ - 219 \\ \hline \end{array}$$

-----C

$$\begin{array}{r} 208 \\ \times 5 \\ \hline \end{array}$$

-----A

$$\begin{array}{r} 208 \\ \div 4 \\ \hline \end{array}$$

-----G

16 's

|   |   |   |   |   |
|---|---|---|---|---|
| 5 | 1 | 2 | 3 | 5 |
| 4 | 5 | 5 | 6 | 3 |
| 3 | 5 | 5 | 2 | 8 |
| 9 | 4 | 6 | 1 | 8 |
| 7 | 9 | 6 | 8 | 8 |

17 's

|   |   |   |   |   |
|---|---|---|---|---|
| 7 | 8 | 2 | 7 | 4 |
| 7 | 3 | 7 | 2 | 9 |
| 8 | 7 | 6 | 4 | 8 |
| 2 | 9 | 2 | 5 | 5 |
| 4 | 5 | 2 | 6 | 7 |

|   | A     | B   | C     |
|---|-------|-----|-------|
| D | 841   | 497 | 150   |
| E | 243   | 126 | 416   |
| F | 1,040 | 144 | 1,191 |
| G | 601   | 562 | 52    |
| H | 208   | 190 | 118   |
| I | 189   | 104 | 124   |
| J | 84    | 589 | 588   |

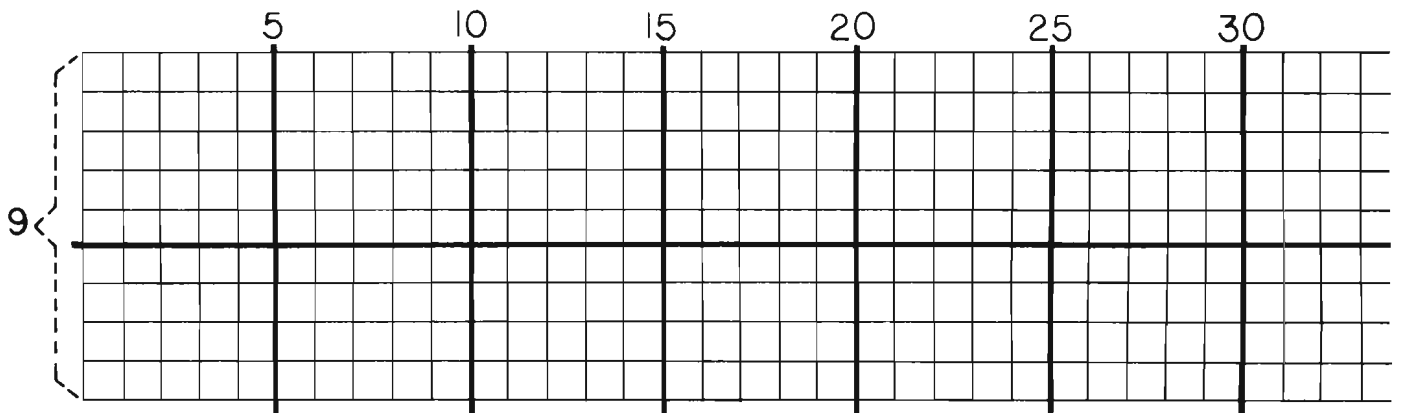

|                          |                          |                          |                          |                          |                          |                          |                          |                          |
|--------------------------|--------------------------|--------------------------|--------------------------|--------------------------|--------------------------|--------------------------|--------------------------|--------------------------|
| $9 \overline{) \quad 1}$ | $9 \overline{) \quad 2}$ | $9 \overline{) \quad 3}$ | $9 \overline{) \quad 4}$ | $9 \overline{) \quad 5}$ | $9 \overline{) \quad 6}$ | $9 \overline{) \quad 7}$ | $9 \overline{) \quad 8}$ | $9 \overline{) \quad 9}$ |
| A                        | B                        | C                        | D                        | E                        | F                        | G                        | H                        | I                        |

|                          |                     |                     |                      |
|--------------------------|---------------------|---------------------|----------------------|
| $9 \overline{) \quad 0}$ | $9 \overline{) 27}$ | $9 \overline{) 90}$ | $9 \overline{) 117}$ |
| J                        | K                   |                     | A                    |

|                     |                     |                     |                     |
|---------------------|---------------------|---------------------|---------------------|
| $9 \overline{) 20}$ | $9 \overline{) 30}$ | $9 \overline{) 40}$ | $9 \overline{) 50}$ |
| B                   | C                   | D                   | E                   |

|                      |                      |                    |                      |
|----------------------|----------------------|--------------------|----------------------|
| $9 \overline{) 279}$ | $9 \overline{) 270}$ | $9 \overline{) 9}$ | $9 \overline{) 189}$ |
| A                    | B                    |                    |                      |

|                      |                      |                     |                      |
|----------------------|----------------------|---------------------|----------------------|
| $9 \overline{) 468}$ | $9 \overline{) 450}$ | $9 \overline{) 18}$ | $9 \overline{) 486}$ |
| C                    |                      | D                   |                      |

|                      |                      |                     |                      |
|----------------------|----------------------|---------------------|----------------------|
| $9 \overline{) 801}$ | $9 \overline{) 720}$ | $9 \overline{) 81}$ | $9 \overline{) 756}$ |
| E                    | F                    |                     |                      |

|                      |                      |                     |                      |
|----------------------|----------------------|---------------------|----------------------|
| $9 \overline{) 873}$ | $9 \overline{) 810}$ | $9 \overline{) 63}$ | $9 \overline{) 855}$ |
| L                    |                      |                     |                      |

|                      |                      |                     |                      |                      |                      |                      |                     |                      |
|----------------------|----------------------|---------------------|----------------------|----------------------|----------------------|----------------------|---------------------|----------------------|
| $9 \overline{) 675}$ | $9 \overline{) 630}$ | $9 \overline{) 45}$ | $9 \overline{) 648}$ | $9 \overline{) 693}$ | $9 \overline{) 387}$ | $9 \overline{) 360}$ | $9 \overline{) 27}$ | $9 \overline{) 432}$ |
| I                    | L                    |                     |                      |                      |                      |                      |                     |                      |

|                      |                      |                      |           |
|----------------------|----------------------|----------------------|-----------|
| 49                   | 7                    |                      | <u>48</u> |
| <input type="text"/> | <input type="text"/> | <input type="text"/> | A         |

|                      |                      |                      |           |
|----------------------|----------------------|----------------------|-----------|
| 49                   | 7                    |                      | <u>71</u> |
| <input type="text"/> | <input type="text"/> | <input type="text"/> | C         |

|                      |                      |                      |            |
|----------------------|----------------------|----------------------|------------|
| 49                   | 7                    |                      | <u>104</u> |
| <input type="text"/> | <input type="text"/> | <input type="text"/> | C          |

|                      |                      |                      |           |
|----------------------|----------------------|----------------------|-----------|
| 64                   | 8                    |                      | <u>63</u> |
| <input type="text"/> | <input type="text"/> | <input type="text"/> | A         |

|                      |                      |                      |           |
|----------------------|----------------------|----------------------|-----------|
| 64                   | 8                    |                      | <u>97</u> |
| <input type="text"/> | <input type="text"/> | <input type="text"/> | C         |

|                      |                      |                      |            |
|----------------------|----------------------|----------------------|------------|
| 64                   | 8                    |                      | <u>161</u> |
| <input type="text"/> | <input type="text"/> | <input type="text"/> | C          |

|                      |                      |                      |           |
|----------------------|----------------------|----------------------|-----------|
| 81                   | 9                    |                      | <u>80</u> |
| <input type="text"/> | <input type="text"/> | <input type="text"/> | A         |

|                      |                      |                      |            |
|----------------------|----------------------|----------------------|------------|
| 81                   | 9                    |                      | <u>100</u> |
| <input type="text"/> | <input type="text"/> | <input type="text"/> | A          |

|                      |                      |                      |            |
|----------------------|----------------------|----------------------|------------|
| 81                   | 9                    |                      | <u>190</u> |
| <input type="text"/> | <input type="text"/> | <input type="text"/> | A          |

|   | A     | B   | C     | D   |
|---|-------|-----|-------|-----|
| E | 99    | 45  | 89    | 450 |
| F | 13    | 84  | 54    | 36  |
| G | 31    | 180 | 52    | 63  |
| H | 0,6,6 | 72  | 27    | 54  |
| I | 9     | 75  | 24,1  | 81  |
| J | 0     | 21  | 270   | 360 |
| K | 1,2,1 | 18  | 2,0,6 | 10  |
| L | 2,3,1 | 72  | 1,4,1 | 95  |

BUILDING AND USING TABLES

CONSTRUYENDO Y USANDO TABLAS

|   |  |  |   |   |   |   |   |   |   |
|---|--|--|---|---|---|---|---|---|---|
| $\begin{array}{r} 26 \\ \times 0 \\ \hline 0 \end{array}$ | $\begin{array}{r} 26 \\ \times 1 \\ \hline 26 \end{array}$ | $\begin{array}{r} 26 \\ \times 2 \\ \hline 52 \end{array}$ | $\begin{array}{r} 26 \\ \times 3 \\ \hline \end{array}$ | $\begin{array}{r} 26 \\ \times 4 \\ \hline \end{array}$ | $\begin{array}{r} 26 \\ \times 5 \\ \hline \end{array}$ | $\begin{array}{r} 26 \\ \times 6 \\ \hline \end{array}$ | $\begin{array}{r} 26 \\ \times 7 \\ \hline \end{array}$ | $\begin{array}{r} 26 \\ \times 8 \\ \hline \end{array}$ | $\begin{array}{r} 26 \\ \times 9 \\ \hline \end{array}$ |
|---|--|--|---|---|---|---|---|---|---|

|   |  |  |  |  |  |  |  |  |  |
|---|--|--|--|--|--|--|--|--|--|
| $\begin{array}{r} 26 \\ \times 0 \\ \hline 0 \end{array}$ | $\begin{array}{r} 26 \\ \times 10 \\ \hline 260 \end{array}$ | $\begin{array}{r} 26 \\ \times 20 \\ \hline \end{array}$ | $\begin{array}{r} 26 \\ \times 30 \\ \hline \end{array}$ | $\begin{array}{r} 26 \\ \times 40 \\ \hline \end{array}$ | $\begin{array}{r} 26 \\ \times 50 \\ \hline \end{array}$ | $\begin{array}{r} 26 \\ \times 60 \\ \hline \end{array}$ | $\begin{array}{r} 26 \\ \times 70 \\ \hline \end{array}$ | $\begin{array}{r} 26 \\ \times 80 \\ \hline \end{array}$ | $\begin{array}{r} 26 \\ \times 90 \\ \hline \end{array}$ |
| A   | B  | C  | D  | E  | F  | G  | H  |  |  |

|  |  |  |  |  |
|--|--|--|--|--|
| $\begin{array}{r} 26 \\ \times 14 \\ \hline 104 \\ \hline 260 \\ \hline 364 \end{array}$ | $\begin{array}{r} 26 \\ \times 32 \\ \hline \end{array}$ | $\begin{array}{r} 26 \\ \times 29 \\ \hline \end{array}$ | $\begin{array}{r} 26 \\ \times 71 \\ \hline \end{array}$ | $\begin{array}{r} 26 \\ \times 46 \\ \hline \end{array}$ |
|  | B  | C  | D  | E  |
| $\begin{array}{r} 26 \\ \times 95 \\ \hline \end{array}$                                 | $\begin{array}{r} 26 \\ \times 77 \\ \hline \end{array}$ | $\begin{array}{r} 26 \\ \times 55 \\ \hline \end{array}$ | $\begin{array}{r} 26 \\ \times 88 \\ \hline \end{array}$ | $\begin{array}{r} 26 \\ \times 63 \\ \hline \end{array}$ |
| F  | A  | B  | C  | D  |

Chain Reactions

Reacciones en cadena

9  $\times 2$   $\div 3$   $\div 3$   $\times 2$   $\times 9$   $\div 6$   $\div 3$   $\div 2$  1

---

27  $\div 9$   $\times 7$   $\div 3$   $\times 8$   $\div 7$   $\times 4$   $\div 2$   $\div 2$   $\times 5$   $\div 8$  5

G F

---

5  $\times 2$   $\times 3$   $\div 6$   $\times 4$   $\div 5$   $\div 4$   $\times 3$   $\times 9$   $\div 3$   $\div 9$  1

I

---

2  $\times 4$   $\times 9$   $\div 8$   $\div 3$   $\times 2$   $\times 5$  30

A

---

49  $\div 7$   $\times 8$   $\div 7$   $\times 9$   $\div 8$   $\div 3$  3

E

|   | A     | B     | C     | D     | E     | F     |
|---|-------|-------|-------|-------|-------|-------|
| G | 2,002 | 780   | 2,080 | 234   | 56    | 21    |
| H | 2,340 | 1,430 | 130   | 1,846 | 1,196 | 208   |
| I | 78    | 832   | 1,040 | 156   | 20    | 1,820 |
| J | 72    | 104   | 2,288 | 1,638 | 1,560 | 8     |
| K | 520   | 2     | 754   | 1,300 | 182   | 2,470 |



\$3.60.....  
..... 1 HOUR

| HOURS         | total  |   |
|---------------|--------|---|
| 1             | \$3.60 |   |
| 2             | \$     | B |
| $\frac{1}{2}$ | \$     | C |
| $\frac{1}{4}$ | \$     | D |
|               | \$1.20 | E |
|               | \$9.00 | F |
| 10            | \$     | G |

20 miles /gallon

| gallons        | miles |   |
|----------------|-------|---|
| 2              |       | H |
| 1              | 20    |   |
| $\frac{1}{2}$  |       | J |
| $\frac{1}{4}$  |       | K |
| $\frac{3}{4}$  |       | A |
| $3\frac{1}{2}$ |       | B |
|                | 115   | C |

$\frac{1}{4}$  OFF

| P       | $\frac{3}{4}P$ |   |
|---------|----------------|---|
| \$4.00  | \$             | D |
| 40¢     | ¢              | J |
| \$1.00  | 75¢            |   |
| \$2.00  | \$             | G |
| \$1.20  | \$             | D |
| \$10.00 | \$             | H |
| \$      | \$6.00         | I |

10 MILLIMETERS  
↓  
1 CENTIMETER  
10MM=1CM

| CM             | MM |   |
|----------------|----|---|
| 1              | 10 | J |
| 3              |    | C |
| 10             |    | F |
| $\frac{1}{2}$  |    | K |
| $\frac{1}{10}$ |    | A |
|                | 25 | F |
|                | 21 | G |
|                | 39 | D |

BOOK  
10¢ ea - 3 for 25¢

| books | TOTAL  |   |
|-------|--------|---|
| 1     | 10¢    | A |
| 3     | ¢      |   |
| 4     | 35¢    | G |
| 5     | ¢      | B |
| 6     | ¢      |   |
| 7     | ¢      | G |
| 8     | ¢      | I |
|       | \$1.20 | K |

1,000 METERS  
↓  
1 KILOMETER  
1KM=1000M

| KM             | M     |   |
|----------------|-------|---|
| $\frac{1}{2}$  |       | J |
| 2              | 2,000 | A |
| $\frac{1}{10}$ |       | F |
| 10             |       | K |

|   | A    | B    | C              | D               | E               | F              |
|---|------|------|----------------|-----------------|-----------------|----------------|
| G | 15   | 60   | 1.50           | 35              | $2\frac{1}{10}$ | 3600           |
| H | 360  | 7.50 | 1.80           | 3.00            | 40              | 75             |
| I | 2000 | 70   | $5\frac{3}{4}$ | 8.00            | $\frac{1}{3}$   | $2\frac{1}{2}$ |
| J | 10   | 7.20 | 30             | .90             | 500             | 100            |
| K | 1    | 45   | $10000$        | $3\frac{9}{10}$ | 5               | 14             |

"HOW MANY?"

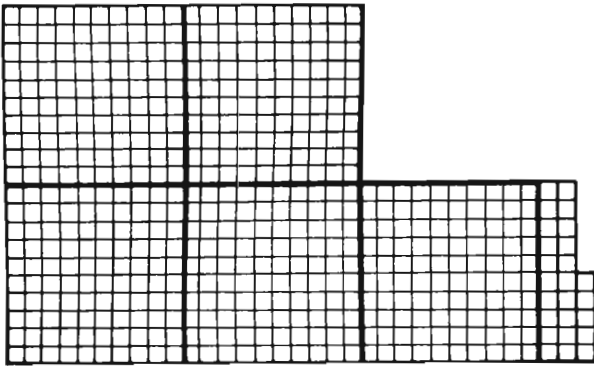

Total -----A

"¿CUANTOS?"

$$\begin{array}{r} 400 \\ + 125 \\ \hline \end{array}$$

-----F

$$\begin{array}{r} 525 \\ + 525 \\ \hline \end{array}$$

-----D

$$\begin{array}{r} 525 \\ \times 2 \\ \hline \end{array}$$

-----C

$$\begin{array}{r} 525 \\ + 307 \\ \hline \end{array}$$

-----B

$$\begin{array}{r} 525 \\ + 175 \\ \hline \end{array}$$

-----E

$$\begin{array}{r} 800 \\ - 278 \\ \hline \end{array}$$

-----G

$$\begin{array}{r} 525 \\ + 181 \\ \hline \end{array}$$

-----C

$$\begin{array}{r} 525 \\ + 199 \\ \hline \end{array}$$

-----F

$$\begin{array}{r} 724 \\ - 198 \\ \hline \end{array}$$

-----

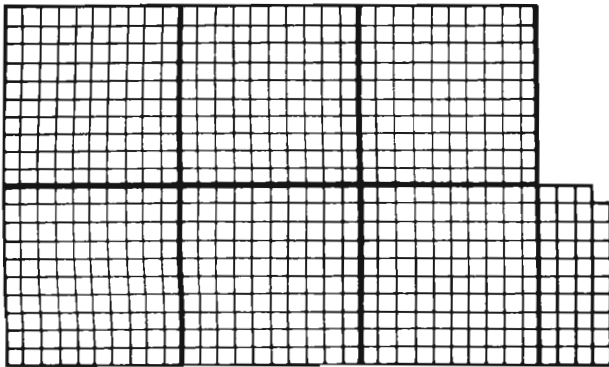

Total -----A

$$\begin{array}{r} 300 \\ + 339 \\ \hline \end{array}$$

-----H

$$\begin{array}{r} 639 \\ + 61 \\ \hline \end{array}$$

-----B

$$\begin{array}{r} 639 \\ + 361 \\ \hline \end{array}$$

-----A

$$\begin{array}{r} 630 \\ - 140 \\ \hline \end{array}$$

-----B

$$\begin{array}{r} 339 \\ + 339 \\ \hline \end{array}$$

-----C

$$\begin{array}{r} 339 \\ \times 2 \\ \hline \end{array}$$

-----B

$$\begin{array}{r} 630 \\ + 75 \\ \hline \end{array}$$

-----C

$$\begin{array}{r} 339 \\ + 393 \\ \hline \end{array}$$

-----D

$$\begin{array}{r} 639 \\ \div 3 \\ \hline \end{array}$$

-----A

"LOOP ARITHMETIC"

"ARITMETICA DE LAZOS"

$$\begin{array}{ccc} 6 & 6 & 6 \\ 7 & 7 & 7 \end{array} \quad (26)$$

$$\begin{array}{ccc} 6 & 6 & 6 \\ 7 & 7 & 7 \end{array} \quad (25)$$

$$\begin{array}{ccc} 5 & 5 & 5 \\ 9 & 9 & 9 \end{array} \quad (32)$$

$$\begin{array}{ccc} 5 & 5 & 5 \\ 9 & 9 & 9 \end{array} \quad (28)$$

$$\begin{array}{ccc} 5 & 5 & 5 \\ 9 & 9 & 9 \end{array} \quad (24)$$

$$\begin{array}{ccc} 3 & 3 & 3 \\ 8 & 8 & 8 \end{array} \quad (24)$$

$$\begin{array}{ccc} 3 & 3 & 3 \\ 8 & 8 & 8 \end{array} \quad (33)$$

$$\begin{array}{ccc} 3 & 3 & 3 \\ 8 & 8 & 8 \end{array} \quad (17)$$

|   | A     | B     | C         |
|---|-------|-------|-----------|
| D | 1,000 | 732   | 1,050     |
| E | 338   | 700   | 706       |
| F | 525   | 490   | 724       |
| G | 213   | 832   | 522       |
| H | 639   | 678   | 705       |
| I | 6,677 | 6,667 | 678       |
| J | 3,338 | 5,559 | 3,338,888 |
| K | 8,888 | 5,599 | 5,999     |

BUILDING AND USING TABLES

CONSTRUYENDO Y USANDO TABLAS

|   |  |  |   |   |   |   |   |   |   |
|---|--|--|---|---|---|---|---|---|---|
| $\begin{array}{r} 12 \\ \times 0 \\ \hline 0 \end{array}$ | $\begin{array}{r} 12 \\ \times 1 \\ \hline 12 \end{array}$ | $\begin{array}{r} 12 \\ \times 2 \\ \hline 24 \end{array}$ | $\begin{array}{r} 12 \\ \times 3 \\ \hline \end{array}$ | $\begin{array}{r} 12 \\ \times 4 \\ \hline \end{array}$ | $\begin{array}{r} 12 \\ \times 5 \\ \hline \end{array}$ | $\begin{array}{r} 12 \\ \times 6 \\ \hline \end{array}$ | $\begin{array}{r} 12 \\ \times 7 \\ \hline \end{array}$ | $\begin{array}{r} 12 \\ \times 8 \\ \hline \end{array}$ | $\begin{array}{r} 12 \\ \times 9 \\ \hline \end{array}$ |
|---|--|--|---|---|---|---|---|---|---|

A B C D E F G

|   |  |  |  |  |  |  |  |  |  |
|---|--|--|--|--|--|--|--|--|--|
| $\begin{array}{r} 12 \\ \times 0 \\ \hline 0 \end{array}$ | $\begin{array}{r} 12 \\ \times 10 \\ \hline 120 \end{array}$ | $\begin{array}{r} 12 \\ \times 20 \\ \hline \end{array}$ | $\begin{array}{r} 12 \\ \times 30 \\ \hline \end{array}$ | $\begin{array}{r} 12 \\ \times 40 \\ \hline \end{array}$ | $\begin{array}{r} 12 \\ \times 50 \\ \hline \end{array}$ | $\begin{array}{r} 12 \\ \times 60 \\ \hline \end{array}$ | $\begin{array}{r} 12 \\ \times 70 \\ \hline \end{array}$ | $\begin{array}{r} 12 \\ \times 80 \\ \hline \end{array}$ | $\begin{array}{r} 12 \\ \times 90 \\ \hline \end{array}$ |
|---|--|--|--|--|--|--|--|--|--|

A B C D E F G H

|   |  |  |
|---|--|--|
| $\begin{array}{r} 12 \\ \times 2 \\ \hline \end{array}$ | $\begin{array}{r} 12 \\ \times 10 \\ \hline \end{array}$ | $\begin{array}{r} 12 \\ \times 12 \\ \hline \end{array}$ |
|---|--|--|

A

|   |  |  |
|---|--|--|
| $\begin{array}{r} 12 \\ \times 4 \\ \hline \end{array}$ | $\begin{array}{r} 12 \\ \times 20 \\ \hline \end{array}$ | $\begin{array}{r} 12 \\ \times 24 \\ \hline \end{array}$ |
|---|--|--|

B

|   |  |  |
|---|--|--|
| $\begin{array}{r} 12 \\ \times 8 \\ \hline \end{array}$ | $\begin{array}{r} 12 \\ \times 50 \\ \hline \end{array}$ | $\begin{array}{r} 12 \\ \times 58 \\ \hline \end{array}$ |
|---|--|--|

C

|   |  |  |
|---|--|--|
| $\begin{array}{r} 12 \\ \times 9 \\ \hline \end{array}$ | $\begin{array}{r} 12 \\ \times 20 \\ \hline \end{array}$ | $\begin{array}{r} 12 \\ \times 29 \\ \hline \end{array}$ |
|---|--|--|

D

|   |  |  |
|---|--|--|
| $\begin{array}{r} 12 \\ \times 3 \\ \hline \end{array}$ | $\begin{array}{r} 12 \\ \times 70 \\ \hline \end{array}$ | $\begin{array}{r} 12 \\ \times 73 \\ \hline \end{array}$ |
|---|--|--|

E

|   |  |  |
|---|--|--|
| $\begin{array}{r} 12 \\ \times 6 \\ \hline \end{array}$ | $\begin{array}{r} 12 \\ \times 60 \\ \hline \end{array}$ | $\begin{array}{r} 12 \\ \times 66 \\ \hline \end{array}$ |
|---|--|--|

F

|   |  |  |
|---|--|--|
| $\begin{array}{r} 12 \\ \times 9 \\ \hline \end{array}$ | $\begin{array}{r} 12 \\ \times 50 \\ \hline \end{array}$ | $\begin{array}{r} 12 \\ \times 59 \\ \hline \end{array}$ |
|---|--|--|

|   |  |  |
|---|--|--|
| $\begin{array}{r} 12 \\ \times 3 \\ \hline \end{array}$ | $\begin{array}{r} 12 \\ \times 80 \\ \hline \end{array}$ | $\begin{array}{r} 12 \\ \times 83 \\ \hline \end{array}$ |
|---|--|--|

J

|   |  |  |
|---|--|--|
| $\begin{array}{r} 12 \\ \times 7 \\ \hline \end{array}$ | $\begin{array}{r} 12 \\ \times 60 \\ \hline \end{array}$ | $\begin{array}{r} 12 \\ \times 67 \\ \hline \end{array}$ |
|---|--|--|

K

$60 = \underline{8 \times 7} + \text{-----C}$

$38 = \underline{9 \times 4} + \text{-----A}$

$48 = \underline{6 \times 8} + \text{-----G}$

$40 = \underline{6 \times 6} + \text{-----D}$

$38 = \underline{5 \times 7} + \text{-----B}$

$31 = \underline{7 \times 4} + \text{-----B}$

$85 = \underline{9 \times 9} + \text{-----F}$

$58 = \underline{9 \times 6} + \text{-----C}$

$78 = \underline{8 \times 9} + \text{-----A}$

$43 = \underline{5 \times 8} + \text{-----D}$

$53 = \underline{7 \times 7} + \text{-----C}$

$28 = \underline{5 \times 5} + \text{-----B}$

$34 = \underline{6 \times 5} + \text{-----F}$

$48 = \underline{9 \times 5} + \text{-----L}$

$65 = \underline{7 \times 9} + \text{-----A}$

$43 = \underline{7 \times 6} + \text{-----E}$

$65 = \underline{8 \times 8} + \text{-----L}$

|   | A   | B   | C   | D     | E   |
|---|-----|-----|-----|-------|-----|
| F | 144 | 840 | 4   | 96    | 792 |
| G | 36  | 0   | 108 | 600   | 960 |
| H | 6   | 360 | 60  | 1,080 | 84  |
| I | 5   | 48  | 708 | 348   | 720 |
| J | 240 | 288 | 996 | 3     | 876 |
| K | 7   | 804 | 696 | 72    | 5   |
| L | 2   | 3   | 480 | 4     | 1   |

$\frac{1}{7}$  of  $\frac{\quad}{A} = \frac{\quad}{B}$        $\frac{2}{7}$  of  $\frac{\quad}{A} = \frac{\quad}{C}$   
 $\frac{3}{7}$  of  $\frac{\quad}{A} = \frac{\quad}{D}$        $\frac{3}{7} - \frac{1}{7} = \frac{\quad}{E}$

$\frac{1}{6}$  of  $\frac{\quad}{A} = \frac{\quad}{B}$        $\frac{1}{3} \times \frac{\quad}{A} = \frac{\quad}{C}$   
 $\frac{1}{2} \times \frac{\quad}{A} = \frac{\quad}{D}$        $\frac{1}{2} - \frac{1}{6} = \frac{\quad}{E}$

$\frac{1}{5}$  of  $\frac{\quad}{J} = \frac{\quad}{B}$        $\frac{1}{10} \times \frac{\quad}{A} = \frac{\quad}{C}$   
 $\frac{3}{5} \times \frac{\quad}{J} = \frac{\quad}{D}$        $\frac{1}{5} - \frac{1}{10} = \frac{\quad}{F}$

$\frac{1}{10} \times \frac{\quad}{A} = \frac{\quad}{B}$        $\frac{4}{10} \times \frac{\quad}{A} = \frac{\quad}{D}$   
 $\frac{1}{2} \times \frac{\quad}{A} = \frac{\quad}{J}$        $\frac{1}{2} - \frac{4}{10} = \frac{\quad}{C}$

Please loop "3 or more neighbors"

Ponga un lazo alrededor de 3 o "más vecinos"

|           |           |           |           |           |           |           |
|-----------|-----------|-----------|-----------|-----------|-----------|-----------|
| A         | B         | C         | H         | E         | F         | J         |
| 9         | 9         | 9         | 9         | 9         | 9         | 9         |
| 4         | 4         | 4         | 4         | 4         | 4         | 4         |
| 6         | 6         | 6         | 6         | 6         | 6         | 6         |
| 5         | 5         | 5         | 5         | 5         | 5         | 5         |
| 7         | 7         | 7         | 7         | 7         | 7         | 7         |
| 8         | 8         | 8         | 8         | 8         | 8         | 8         |
| <u>18</u> | <u>19</u> | <u>20</u> | <u>22</u> | <u>24</u> | <u>26</u> | <u>31</u> |

|   |                     |                   |                   |                            |
|---|---------------------|-------------------|-------------------|----------------------------|
|   | A                   | B                 | C                 | D                          |
| E | $\frac{9,6}{4,5}$   | $\frac{2}{7}$     | 3                 | $\frac{1}{3}, \frac{2}{6}$ |
| F | 5,6                 | $\frac{5,7}{8}$   | $\frac{1}{10}$    | $\frac{6,5}{7,8}$          |
| G | $\frac{6}{5,7}$     | 6                 | 16                | 18                         |
| H | 4,8                 | $\frac{4,6}{5,7}$ | $\frac{5}{7,8}$   | 24                         |
| I | $\frac{9,4}{5,7,8}$ | 8                 | $\frac{4,6}{7,8}$ | $\frac{4,6}{5,7,8}$        |
| J | 60                  | $\frac{9}{4,6}$   | 30                | $\frac{9,4,6}{5,7}$        |

"HOW MANY?"

"¿CUANTOS?"

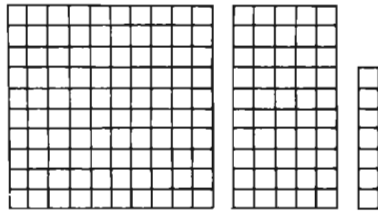

Total -----A

$$\begin{array}{r} 150 \\ + 7 \\ \hline \end{array}$$

-----F

$$\begin{array}{r} 150 \\ + 57 \\ \hline \end{array}$$

-----B

$$\begin{array}{r} 157 \\ + 57 \\ \hline \end{array}$$

-----C

$$\begin{array}{r} 157 \\ + 157 \\ \hline \end{array}$$

-----D

$$\begin{array}{r} 314 \\ + 157 \\ \hline \end{array}$$

-----A

$$\begin{array}{r} 200 \\ - 157 \\ \hline \end{array}$$

-----G

$$\begin{array}{r} 157 \\ \times 2 \\ \hline \end{array}$$

-----C

$$\begin{array}{r} 157 \\ \times 3 \\ \hline \end{array}$$

-----J

$$\begin{array}{r} 314 \\ \div 2 \\ \hline \end{array}$$

-----A

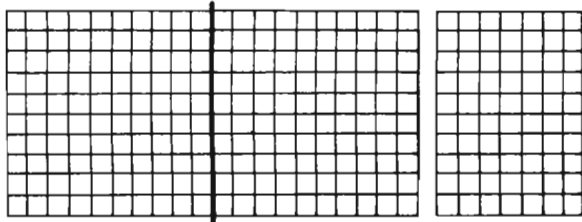

Total -----A

$$\begin{array}{r} 300 \\ - 270 \\ \hline \end{array}$$

-----B

$$\begin{array}{r} 270 \\ - 75 \\ \hline \end{array}$$

-----C

$$\begin{array}{r} 570 \\ - 180 \\ \hline \end{array}$$

-----A

$$\begin{array}{r} 270 \\ + 270 \\ \hline \end{array}$$

-----D

$$\begin{array}{r} 540 \\ + 270 \\ \hline \end{array}$$

-----C

$$\begin{array}{r} 135 \\ + 135 \\ \hline \end{array}$$

-----I

$$\begin{array}{r} 270 \\ \times 2 \\ \hline \end{array}$$

-----B

$$\begin{array}{r} 270 \\ \div 3 \\ \hline \end{array}$$

-----H

$$\begin{array}{r} 270 \\ \div 9 \\ \hline \end{array}$$

-----J

Chain Reactions

Reaccion en cadenas

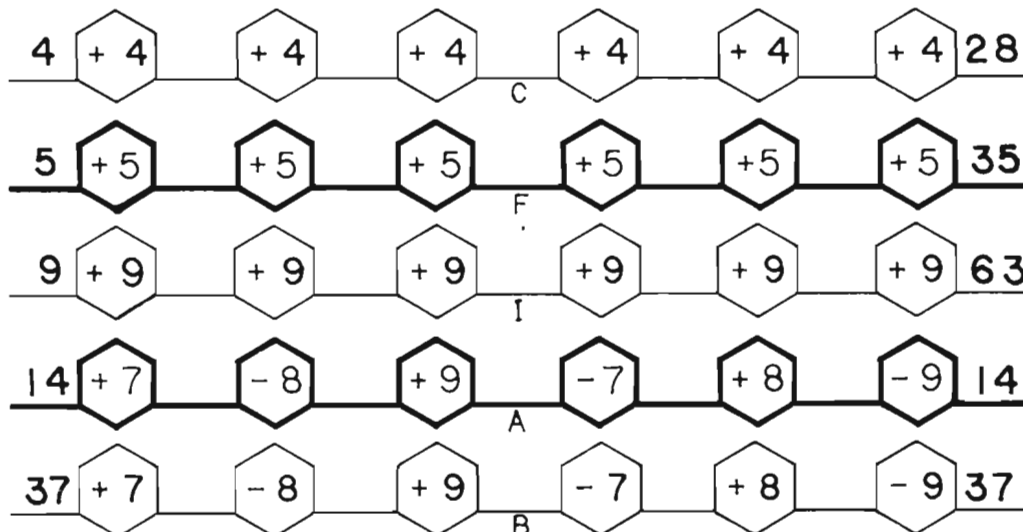

|   | A   | B   | C   |
|---|-----|-----|-----|
| D | 51  | 540 | 314 |
| E | 390 | 207 | 16  |
| F | 157 | 45  | 20  |
| G | 22  | 43  | 214 |
| H | 145 | 453 | 90  |
| I | 270 | 36  | 195 |
| J | 471 | 30  | 810 |

### Addition

Sumar

$$\begin{array}{r} 343 \\ +150 \\ \hline \end{array} \quad \begin{array}{r} 343 \\ +159 \\ \hline \end{array}$$

$$\begin{array}{r} 743 \\ +197 \\ \hline \end{array} \quad \begin{array}{r} 743 \\ +408 \\ \hline \end{array}$$

$$\begin{array}{r} 343 \\ 343 \\ +343 \\ \hline \end{array} \quad \begin{array}{r} 343 \\ \times 3 \\ \hline \end{array}$$

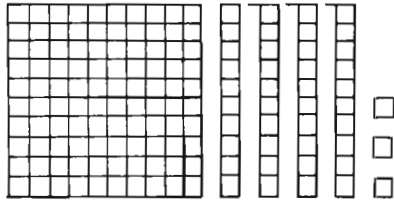
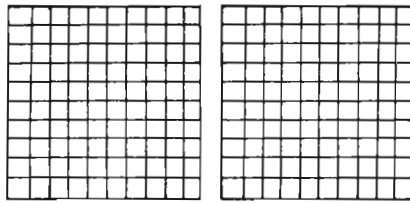

---343---

### Subtraction

Restar

$$\begin{array}{r} 343 \\ -19 \\ \hline \end{array} \quad \begin{array}{r} 300 \\ -43 \\ \hline \end{array}$$

$$\begin{array}{r} 743 \\ -181 \\ \hline \end{array} \quad \begin{array}{r} 743 \\ -388 \\ \hline \end{array}$$

$$\begin{array}{r} 800 \\ -7 \\ \hline \end{array} \quad \begin{array}{r} 312 \\ \div 3 \\ \hline \end{array}$$

|            |            |            |            |            |            |            |            |            |            |            |            |            |            |
|------------|------------|------------|------------|------------|------------|------------|------------|------------|------------|------------|------------|------------|------------|
| 0          | 1          | 2          | 3          | 4          | 5          | 6          | 7          | 8          | 9          | 10         | 11         | 12         | 13         |
| $\times 9$ | $\times 9$ | $\times 9$ | $\times 9$ | $\times 9$ | $\times 9$ | $\times 9$ | $\times 9$ | $\times 9$ | $\times 9$ | $\times 9$ | $\times 9$ | $\times 9$ | $\times 9$ |

|            |            |            |
|------------|------------|------------|
| 20         | 30         | 40         |
| $\times 9$ | $\times 9$ | $\times 9$ |

|            |            |            |
|------------|------------|------------|
| 5          | 25         | 50         |
| $\times 9$ | $\times 9$ | $\times 9$ |

|            |            |            |
|------------|------------|------------|
| 9          | 69         | 60         |
| $\times 9$ | $\times 9$ | $\times 9$ |

|            |            |            |
|------------|------------|------------|
| 12         | 24         | 48         |
| $\times 9$ | $\times 9$ | $\times 9$ |

|                     |                     |                     |                     |
|---------------------|---------------------|---------------------|---------------------|
| $9 \overline{)10}$  | $9 \overline{)20}$  | $9 \overline{)30}$  | $9 \overline{)40}$  |
| $9 \overline{)72}$  | $9 \overline{)54}$  | $9 \overline{)81}$  | $9 \overline{)63}$  |
| $9 \overline{)162}$ | $9 \overline{)234}$ | $9 \overline{)351}$ | $9 \overline{)423}$ |

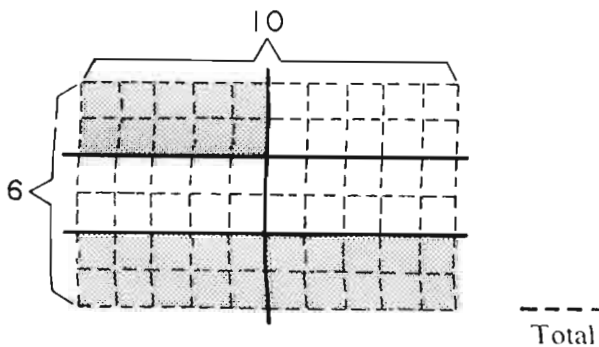

$$\frac{1}{3} \text{ of } \underline{60} = \text{---}$$

$$\frac{1}{2} \times \underline{60} = \text{---}$$

$$\frac{1}{6} \times \underline{60} = \text{---}$$

$$\frac{1}{6} + \frac{1}{3} = \text{---}$$

$\frac{1}{4}$  OFF

$\$1 = 10$  (10¢)

| P       | $\frac{3}{4}$ P |
|---------|-----------------|
| 80¢     | ¢               |
| \$12.00 | \$              |
| ¢       | 30¢             |
| \$1.60  | \$              |
| \$      | \$6.00          |

| DOLLARS        | dimes |
|----------------|-------|
| 2              |       |
| $\frac{1}{2}$  |       |
| $\frac{1}{10}$ |       |



Division examples with "Remainders"

Ejemplos de división con "Restantes"

$$4 \overline{)30} \quad ?$$

7 hileras iguales y sobran dos  
7 rows alike and 2 left over

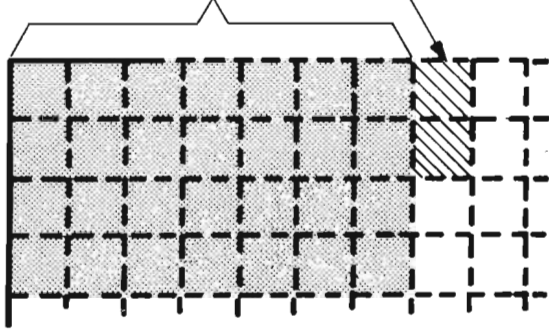

(a)  $7 \overset{R2}{4 \overline{)30}}$     or    (b)  $7 \overset{2}{4 \overline{)30}}$     or    (c)  $7 \overset{\frac{1}{2}}{4 \overline{)30}}$

- (a) "7 and remainder of 2"
- (b) "7 and 2 out of the 4 needed" to complete another column
- (c) "7 and  $\frac{1}{2}$  of those needed" to complete another column

- (a) "7 y restante de 2"
- (b) "7 y 2 de los 4 se necesitan" para completar otra columna.
- (c) "7 y  $\frac{1}{2}$  de los que se necesitan" para completar otra columna.

| A                  | B               | C               | D                  | E                  | F               | G                  | H                  |   |
|--------------------|-----------------|-----------------|--------------------|--------------------|-----------------|--------------------|--------------------|---|
| $5 \frac{1}{2}$    | $9 \frac{1}{2}$ | $8 \frac{1}{3}$ | $8 \frac{1}{2}$    | $6 \frac{4}{6}$    | $6 \frac{1}{8}$ | $7 \frac{3}{5}$    | $9 \frac{1}{2}$    | I |
| $8 \overset{R2}{}$ | $9 \frac{4}{8}$ | $5 \frac{1}{2}$ | $5 \overset{R7}{}$ | $6 \overset{R4}{}$ | $6 \frac{2}{3}$ | $8 \overset{R2}{}$ | $8 \frac{2}{4}$    | J |
| $7 \overset{R3}{}$ | $8 \frac{2}{6}$ | $7 \frac{2}{3}$ | $6 \overset{R4}{}$ | $4 \overset{R3}{}$ | $5 \frac{1}{5}$ | $6 \frac{4}{5}$    | $7 \overset{R1}{}$ | K |

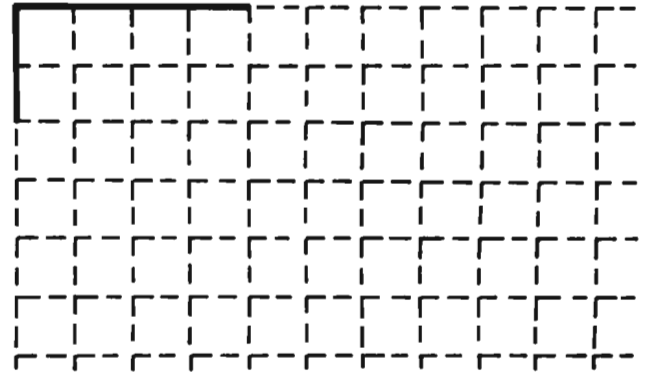

$6 \overset{D}{\overline{)40}}$     or     $6 \overset{E}{\overline{)40}}$     or     $6 \overset{F}{\overline{)40}}$

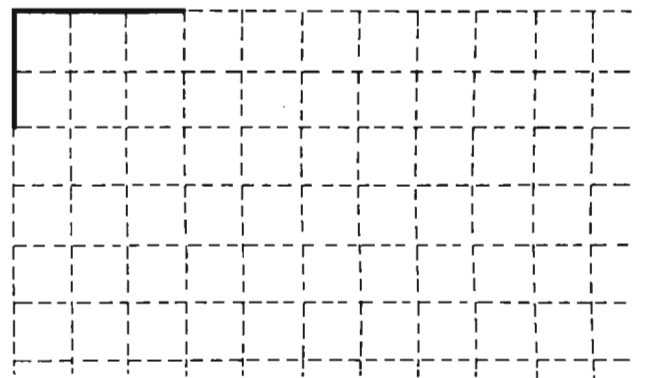

$4 \overset{G}{\overline{)34}}$     or     $4 \overset{H}{\overline{)34}}$     or     $4 \overset{I}{\overline{)34}}$

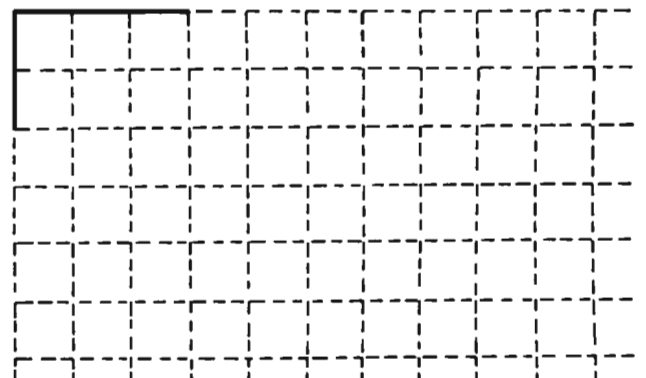

$5 \overset{J}{\overline{)34}}$     or     $5 \overset{K}{\overline{)34}}$

a special problem

un problema especial

$$\begin{array}{r} \cancel{6}9\cancel{1} \\ \cancel{7}04 \\ - \quad 68 \\ \hline 3 \end{array} \quad \begin{array}{r} 704 \\ - \quad 68 \\ \hline \end{array} \quad \text{A}$$

$$\begin{array}{r} \cancel{4}9\cancel{1} \\ \cancel{5}00 \\ - \quad 147 \\ \hline \end{array} \quad \begin{array}{r} 500 \\ - \quad 147 \\ \hline \end{array} \quad \text{B}$$

$$\begin{array}{r} \cancel{7}9\cancel{1} \\ \cancel{8}045 \\ - \quad 2,783 \\ \hline 2 \end{array} \quad \begin{array}{r} 8,045 \\ - \quad 2,783 \\ \hline \end{array} \quad \text{C}$$

$$\begin{array}{r} \cancel{7}9\cancel{1} \\ \cancel{8}03 \\ - \quad 359 \\ \hline \end{array} \quad \begin{array}{r} 803 \\ - \quad 359 \\ \hline \end{array} \quad \text{D}$$

$$\begin{array}{r} \cancel{2}9\cancel{1} \\ \cancel{1,3}00 \\ - \quad 896 \\ \hline \end{array} \quad \begin{array}{r} 1,300 \\ - \quad 896 \\ \hline \end{array} \quad \text{E}$$

$$\begin{array}{r} \cancel{4}9\cancel{1} \\ \cancel{5}073 \\ - \quad 1,892 \\ \hline \end{array} \quad \begin{array}{r} 5,073 \\ - \quad 1,892 \\ \hline \end{array} \quad \text{F}$$

$$\begin{array}{r} \cancel{6}9\cancel{1} \\ \cancel{7}004 \\ - \quad 1,068 \\ \hline \end{array} \quad \begin{array}{r} \cancel{6}9\cancel{9} \\ \cancel{7}004 \\ - \quad 1,068 \\ \hline \end{array} \quad \begin{array}{r} 7,004 \\ - \quad 1,068 \\ \hline \end{array} \quad \text{G}$$

$$\begin{array}{r} \cancel{8}9\cancel{1} \\ \cancel{9}000 \\ - \quad 1,745 \\ \hline \end{array} \quad \begin{array}{r} \cancel{8}9\cancel{9} \\ \cancel{9}000 \\ - \quad 1,745 \\ \hline \end{array} \quad \begin{array}{r} 9,000 \\ - \quad 1,745 \\ \hline \end{array} \quad \text{H}$$

$$\begin{array}{r} \cancel{7}9\cancel{1} \\ \cancel{8}003 \\ - \quad 2,359 \\ \hline \end{array} \quad \begin{array}{r} \cancel{7}9\cancel{9} \\ \cancel{8}003 \\ - \quad 2,359 \\ \hline \end{array} \quad \begin{array}{r} 8,003 \\ - \quad 2,359 \\ \hline \end{array} \quad \text{I}$$

$$\begin{array}{r} \cancel{1}2\cancel{9} \\ \cancel{1}3000 \\ - \quad 4,896 \\ \hline \end{array} \quad \begin{array}{r} \cancel{1}2\cancel{9} \\ \cancel{1}3000 \\ - \quad 4,896 \\ \hline \end{array} \quad \begin{array}{r} 13,000 \\ - \quad 4,896 \\ \hline \end{array} \quad \text{J}$$

$29 = 3 \times 9 + \text{-----A}$

$49 = 8 \times 6 + \text{-----A}$

$49 = 5 \times 9 + \text{-----A}$

$59 = 7 \times 8 + \text{-----B}$

$39 = 9 \times 4 + \text{-----B}$

$69 = 8 \times 8 + \text{-----B}$

$79 = 8 \times 9 + \text{-----C}$

$49 = 7 \times 7 + \text{-----C}$

$59 = 9 \times 6 + \text{-----D}$

$79 = 8 \times 9 + \text{-----D}$

$45 = 8 \times 5 + \text{-----E}$

$45 = 6 \times 7 + \text{-----E}$

$69 = 7 \times 9 + \text{-----F}$

$89 = 9 \times 9 + \text{-----F}$

|   | A   | B     | C     | D     | E     |
|---|-----|-------|-------|-------|-------|
| F | 7   | 3     | 8     | 3,181 | 6     |
| G | 636 | 8     | 5,262 | 9     | 5,936 |
| H | 4   | 353   | 10    | 7,255 | 5     |
| I | 11  | 5     | 5,644 | 7     | 404   |
| J | 2   | 8,104 | 0     | 5     | 3     |
| K | 12  | 16    | 7     | 444   | 13    |
| L | 1   | 18    | 14    | 17    | 15    |



1 P..... 4¢  
3 P..... 10¢

| total | P  |   |
|-------|----|---|
| 4¢    | 1  |   |
| ¢     | 2  | B |
| 10¢   | 3  |   |
| ¢     | 4  | D |
| 24¢   |    | E |
| 34¢   |    | F |
| ¢     | 15 | H |

15 MILES.....GALLON

| MILES          | GALLONS        |   |
|----------------|----------------|---|
| 15             | 1              |   |
| 45             |                | I |
| 150            |                | H |
| $7\frac{1}{2}$ |                | A |
|                | $\frac{1}{3}$  | B |
|                | $1\frac{2}{3}$ | C |
| 75             |                | I |

1 DOLLAR = 100¢

| dollars            | ¢    |   |
|--------------------|------|---|
| \$ 2               | 200¢ |   |
| $\$ \frac{1}{2}$   | ¢    | D |
| $\$ \frac{3}{4}$   | ¢    | E |
| \$                 | 500¢ | B |
| $\$ 3\frac{1}{4}$  | ¢    | I |
| $\$ 1\frac{7}{10}$ | ¢    | H |
| $\$ 2\frac{3}{10}$ | ¢    | J |

1 M = 100 cm

| M               | cm  |   |
|-----------------|-----|---|
| 2               | 200 |   |
| $\frac{1}{2}$   |     | H |
| $\frac{3}{4}$   |     | E |
|                 | 500 | I |
| $3\frac{1}{4}$  |     | F |
| $1\frac{7}{10}$ |     | B |
| $2\frac{3}{10}$ |     | F |
| $\frac{1}{100}$ |     | A |

$\frac{1}{3}$  OFF

| P      | $\frac{2}{3} P$ |   |
|--------|-----------------|---|
| 30¢    | 20¢             |   |
| 42¢    | ¢               | D |
| 27¢    | ¢               | F |
| ¢      | 10¢             | C |
| 21¢    | ¢               | G |
| \$3.00 | \$              | K |
| \$7.50 | \$              | J |
| \$1.20 | ¢               | B |

1 HOUR...480 miles

| HOURS          | miles |   |
|----------------|-------|---|
| $\frac{1}{2}$  | 240   |   |
| $\frac{1}{4}$  |       | K |
| $\frac{3}{4}$  |       | F |
| $2\frac{1}{2}$ |       | G |

|   | A             | B   | C    | D    | E     | F   |
|---|---------------|-----|------|------|-------|-----|
| G | 1             | 8   | 15   | 14   | 1,200 | 360 |
| H | 4             | 170 | 25   | 50   | 75    | 10  |
| I | $\frac{1}{2}$ | 5   | 3    | 28   | 7     | 325 |
| J | 90            | 2   | 15   | 5,00 | 200   | 230 |
| K | 120           | 80  | 2,00 | 72   | 240   | 18  |

"HOW MANY?"

"¿CUANTOS?"

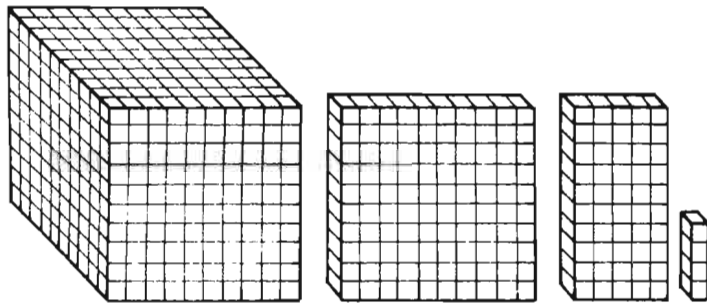

$$\begin{array}{r} 100 \\ - 45 \\ \hline \end{array}$$

$$\begin{array}{r} 145 \\ - 50 \\ \hline \end{array}$$

$$\begin{array}{r} 145 \\ - 59 \\ \hline \end{array}$$

Total -----

$$\begin{array}{r} 1,150 \\ - 725 \\ \hline \end{array}$$

$$\begin{array}{r} 1,154 \\ - 308 \\ \hline \end{array}$$

$$\begin{array}{r} 1,154 \\ - 1,092 \\ \hline \end{array}$$

$$\begin{array}{r} 1,154 \\ + 1,154 \\ \hline \end{array}$$

$$\begin{array}{r} 1,154 \\ \times 2 \\ \hline \end{array}$$

$$\begin{array}{r} 1,154 \\ \div 2 \\ \hline \end{array}$$

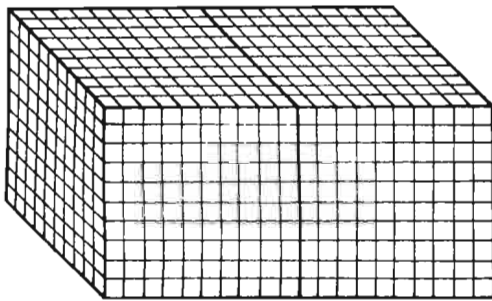

-----  
Total

$$\begin{array}{r} 378 \\ - 109 \\ \hline \end{array}$$

$$\begin{array}{r} 378 \\ - 287 \\ \hline \end{array}$$

$$\begin{array}{r} 378 \\ - 189 \\ \hline \end{array}$$

$$\begin{array}{r} 2,378 \\ - 1,349 \\ \hline \end{array}$$

$$\begin{array}{r} 2,378 \\ - 1,289 \\ \hline \end{array}$$

$$\begin{array}{r} 2,378 \\ - 1,419 \\ \hline \end{array}$$

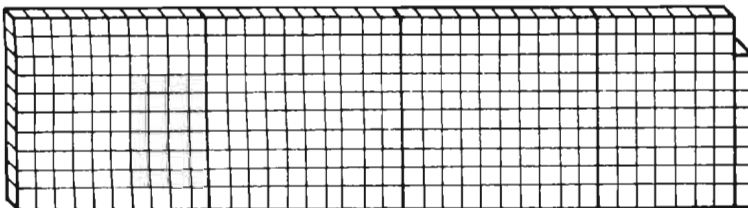

$$\begin{array}{r} 2,378 \\ + 2,378 \\ \hline \end{array}$$

$$\begin{array}{r} 2,378 \\ \times 2 \\ \hline \end{array}$$

$$\begin{array}{r} 2,378 \\ \div 2 \\ \hline \end{array}$$

Please use the smallest whole numbers. Favor de usar los números más pequeños.

$$\begin{array}{r} 4 \quad 2 \quad 1 \\ \hline \phantom{0} \phantom{0} \phantom{0} \end{array} \underline{5}$$

$$\begin{array}{r} 9 \quad 3 \quad 1 \\ \hline \phantom{0} \phantom{0} \phantom{0} \end{array} \underline{23}$$

$$\begin{array}{r} 16 \quad 4 \quad 1 \\ \hline \phantom{0} \phantom{0} \phantom{0} \end{array} \underline{49}$$

$$\begin{array}{r} 25 \quad 5 \quad 1 \\ \hline \phantom{0} \phantom{0} \phantom{0} \end{array} \underline{89}$$

$$\begin{array}{r} 36 \quad 6 \quad 1 \\ \hline \phantom{0} \phantom{0} \phantom{0} \end{array} \underline{67}$$

$$\begin{array}{r} 49 \quad 7 \quad 1 \\ \hline \phantom{0} \phantom{0} \phantom{0} \end{array} \underline{125}$$

$$\begin{array}{r} 64 \quad 8 \quad 1 \\ \hline \phantom{0} \phantom{0} \phantom{0} \end{array} \underline{100}$$

$$\begin{array}{r} 81 \quad 9 \quad 1 \\ \hline \phantom{0} \phantom{0} \phantom{0} \end{array} \underline{200}$$

$$\begin{array}{r} 00 \quad 10 \quad 1 \\ \hline \phantom{0} \phantom{0} \phantom{0} \end{array} \underline{376}$$



How do you feel?  
¿Cómo se siente?

BUILDING AND USING TABLES

CONSTRUYENDO Y USANDO TABLAS

|   |  |  |   |   |   |   |   |   |   |
|---|--|--|---|---|---|---|---|---|---|
| $\begin{array}{r} 15 \\ \times 0 \\ \hline 0 \end{array}$ | $\begin{array}{r} 15 \\ \times 1 \\ \hline 15 \end{array}$ | $\begin{array}{r} 15 \\ \times 2 \\ \hline 30 \end{array}$ | $\begin{array}{r} 15 \\ \times 3 \\ \hline \end{array}$ | $\begin{array}{r} 15 \\ \times 4 \\ \hline \end{array}$ | $\begin{array}{r} 15 \\ \times 5 \\ \hline \end{array}$ | $\begin{array}{r} 15 \\ \times 6 \\ \hline \end{array}$ | $\begin{array}{r} 15 \\ \times 7 \\ \hline \end{array}$ | $\begin{array}{r} 15 \\ \times 8 \\ \hline \end{array}$ | $\begin{array}{r} 15 \\ \times 9 \\ \hline \end{array}$ |
|   |  |  | A   | B   | C   | D   | E   | F   | G   |

|   |  |  |  |  |  |  |  |  |  |
|---|--|--|--|--|--|--|--|--|--|
| $\begin{array}{r} 15 \\ \times 0 \\ \hline 0 \end{array}$ | $\begin{array}{r} 15 \\ \times 10 \\ \hline 150 \end{array}$ | $\begin{array}{r} 15 \\ \times 20 \\ \hline \end{array}$ | $\begin{array}{r} 15 \\ \times 30 \\ \hline \end{array}$ | $\begin{array}{r} 15 \\ \times 40 \\ \hline \end{array}$ | $\begin{array}{r} 15 \\ \times 50 \\ \hline \end{array}$ | $\begin{array}{r} 15 \\ \times 60 \\ \hline \end{array}$ | $\begin{array}{r} 15 \\ \times 70 \\ \hline \end{array}$ | $\begin{array}{r} 15 \\ \times 80 \\ \hline \end{array}$ | $\begin{array}{r} 15 \\ \times 90 \\ \hline \end{array}$ |
|   |  | H  | I  | J  | A  | B  | C  | D  | E  |

$\begin{array}{r} 15 \\ \times 379 \\ \hline 1300 \\ 79 \\ 75 \\ \hline \end{array}$

R4  
 2 5  
 3 7 9  
 3 0 0  
 7 9  
 7 5  
 4

L R  
 $\begin{array}{r} 15 \\ \times 187 \\ \hline \end{array}$

K R  
 $\begin{array}{r} 15 \\ \times 971 \\ \hline \end{array}$

M R  
 $\begin{array}{r} 15 \\ \times 1292 \\ \hline \end{array}$

K R  
 $\begin{array}{r} 15 \\ \times 861 \\ \hline \end{array}$

M R  
 $\begin{array}{r} 15 \\ \times 1396 \\ \hline \end{array}$

L R  
 $\begin{array}{r} 15 \\ \times 464 \\ \hline \end{array}$

K R  
 $\begin{array}{r} 15 \\ \times 703 \\ \hline \end{array}$

Smallest Numbers ...

Números más pequeños...

|   |                 |                 |  |   |  |  |  |   |  |  |  |
|---|-----------------|-----------------|--|---|--|--|--|---|--|--|--|
| $\begin{array}{r} 25 \\ \times \end{array}$ <table border="1" style="display: inline-table; vertical-align: middle;"> <tr><td> </td><td> </td><td> </td></tr> </table> $\underline{\hspace{1cm}}$ |                 |                 |  | $\begin{array}{r} 25 \\ \times \end{array}$ <table border="1" style="display: inline-table; vertical-align: middle;"> <tr><td> </td><td> </td><td> </td></tr> </table> $\underline{\hspace{1cm}}$ |  |  |  | $\begin{array}{r} 25 \\ \times \end{array}$ <table border="1" style="display: inline-table; vertical-align: middle;"> <tr><td> </td><td> </td><td> </td></tr> </table> $\underline{\hspace{1cm}}$ |  |  |  |
|   |                 |                 |  |   |  |  |  |   |  |  |  |
|   |                 |                 |  |   |  |  |  |   |  |  |  |
|   |                 |                 |  |   |  |  |  |   |  |  |  |
| 108 <sub>M</sub>  | 73 <sub>K</sub> | 124             |  |   |  |  |  |   |  |  |  |
| $\begin{array}{r} 25 \\ \times \end{array}$ <table border="1" style="display: inline-table; vertical-align: middle;"> <tr><td> </td><td> </td><td> </td></tr> </table> $\underline{\hspace{1cm}}$ |                 |                 |  | $\begin{array}{r} 25 \\ \times \end{array}$ <table border="1" style="display: inline-table; vertical-align: middle;"> <tr><td> </td><td> </td><td> </td></tr> </table> $\underline{\hspace{1cm}}$ |  |  |  | $\begin{array}{r} 25 \\ \times \end{array}$ <table border="1" style="display: inline-table; vertical-align: middle;"> <tr><td> </td><td> </td><td> </td></tr> </table> $\underline{\hspace{1cm}}$ |  |  |  |
|   |                 |                 |  |   |  |  |  |   |  |  |  |
|   |                 |                 |  |   |  |  |  |   |  |  |  |
|   |                 |                 |  |   |  |  |  |   |  |  |  |
| 79 <sub>L</sub>   | 47 <sub>M</sub> | 96              |  |   |  |  |  |   |  |  |  |
| $\begin{array}{r} 25 \\ \times \end{array}$ <table border="1" style="display: inline-table; vertical-align: middle;"> <tr><td> </td><td> </td><td> </td></tr> </table> $\underline{\hspace{1cm}}$ |                 |                 |  | $\begin{array}{r} 25 \\ \times \end{array}$ <table border="1" style="display: inline-table; vertical-align: middle;"> <tr><td> </td><td> </td><td> </td></tr> </table> $\underline{\hspace{1cm}}$ |  |  |  | $\begin{array}{r} 25 \\ \times \end{array}$ <table border="1" style="display: inline-table; vertical-align: middle;"> <tr><td> </td><td> </td><td> </td></tr> </table> $\underline{\hspace{1cm}}$ |  |  |  |
|   |                 |                 |  |   |  |  |  |   |  |  |  |
|   |                 |                 |  |   |  |  |  |   |  |  |  |
|   |                 |                 |  |   |  |  |  |   |  |  |  |
| 112 <sub>K</sub>  | 93 <sub>L</sub> | 24              |  |   |  |  |  |   |  |  |  |
| $\begin{array}{r} 25 \\ \times \end{array}$ <table border="1" style="display: inline-table; vertical-align: middle;"> <tr><td> </td><td> </td><td> </td></tr> </table> $\underline{\hspace{1cm}}$ |                 |                 |  | $\begin{array}{r} 25 \\ \times \end{array}$ <table border="1" style="display: inline-table; vertical-align: middle;"> <tr><td> </td><td> </td><td> </td></tr> </table> $\underline{\hspace{1cm}}$ |  |  |  | $\begin{array}{r} 25 \\ \times \end{array}$ <table border="1" style="display: inline-table; vertical-align: middle;"> <tr><td> </td><td> </td><td> </td></tr> </table> $\underline{\hspace{1cm}}$ |  |  |  |
|   |                 |                 |  |   |  |  |  |   |  |  |  |
|   |                 |                 |  |   |  |  |  |   |  |  |  |
|   |                 |                 |  |   |  |  |  |   |  |  |  |
| 65 <sub>M</sub>   | 75              | 74 <sub>M</sub> |  |   |  |  |  |   |  |  |  |

|   | K         | L         | M        |
|---|-----------|-----------|----------|
| A | 750       | 45        | 1,4,2    |
| B | 60        | 3,0,4     | 900      |
| C | R13<br>46 | 1,050     | 75       |
| D | 1,200     | 90        | 2,3,0    |
| E | 4,2,2     | 1,350     | 105      |
| F | 120       | R7<br>12  | 2,4,4    |
| G | R11<br>64 | R14<br>30 | 135      |
| H | 2,4,3     | 300       | R2<br>86 |
| I | R6<br>57  | 450       | 4,1,3    |
| J | 600       | 3,3,3     | R1<br>93 |

13's

|   |   |   |   |   |
|---|---|---|---|---|
| 4 | 4 | 4 | 3 | 9 |
| 1 | 6 | 1 | 1 | 4 |
| 5 | 7 | 3 | 4 | 3 |
| 5 | 3 | 5 | 2 | 6 |
| 5 | 6 | 2 | 9 | 2 |

14's

|   |   |   |   |   |
|---|---|---|---|---|
| 3 | 5 | 7 | 2 | 5 |
| 6 | 1 | 7 | 5 | 8 |
| 4 | 6 | 5 | 9 | 1 |
| 7 | 3 | 4 | 5 | 2 |
| 5 | 3 | 3 | 3 | 3 |

15's

|   |   |   |   |   |
|---|---|---|---|---|
| 7 | 6 | 5 | 4 | 4 |
| 1 | 3 | 4 | 6 | 7 |
| 1 | 3 | 6 | 8 | 4 |
| 6 | 3 | 9 | 3 | 4 |
| 8 | 7 | 4 | 4 | 3 |

Chain Reactions

Reacción en cadena

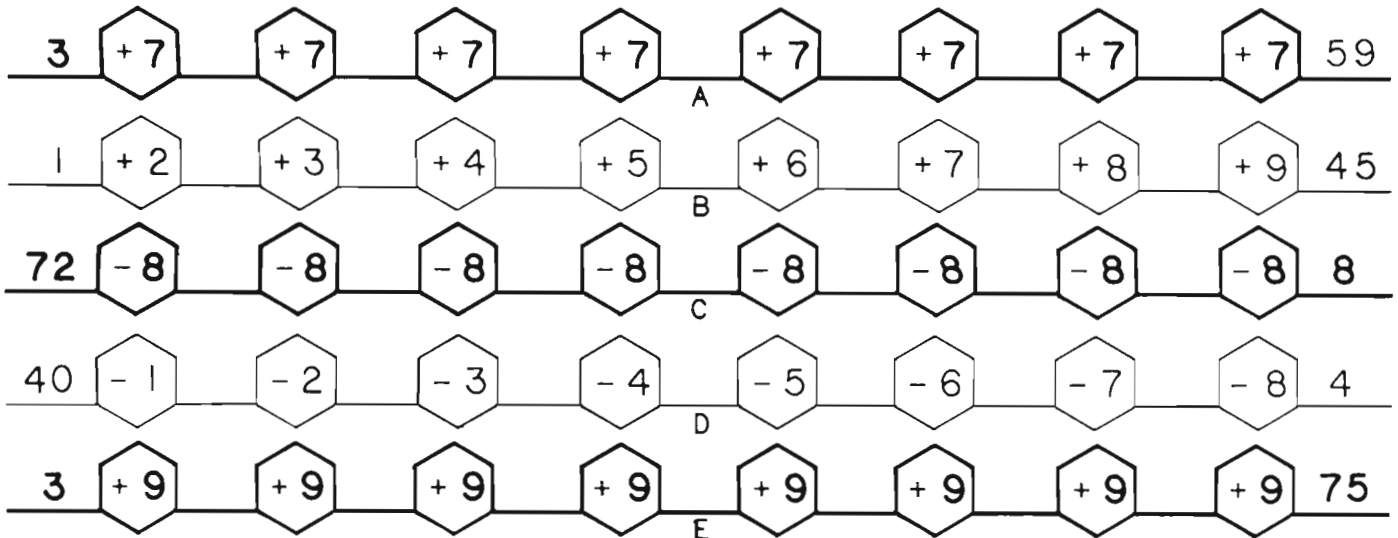

$$47 = \underline{6 \times 7} + \text{-----} \text{ F}$$

$$44 = \underline{8 \times 5} + \text{-----} \text{ F}$$

$$65 = \underline{8 \times 8} + \text{-----} \text{ G}$$

$$59 = \underline{6 \times 9} + \text{-----} \text{ G}$$

$$65 = \underline{9 \times 7} + \text{-----} \text{ A}$$

$$59 = \underline{7 \times 8} + \text{-----} \text{ A}$$

$$38 = \underline{7 \times 5} + \text{-----} \text{ B}$$

$$49 = \underline{9 \times 5} + \text{-----} \text{ B}$$

$$50 = \underline{8 \times 6} + \text{-----} \text{ C}$$

$$39 = \underline{6 \times 6} + \text{-----} \text{ C}$$

$$50 = \underline{7 \times 7} + \text{-----} \text{ D}$$

$$89 = \underline{9 \times 9} + \text{-----} \text{ D}$$

$$75 = \underline{8 \times 9} + \text{-----} \text{ E}$$

$$35 = \underline{4 \times 8} + \text{-----} \text{ E}$$

|   | H  | I  | J  |
|---|----|----|----|
| A | 2  | 3  | 31 |
| B | 4  | 15 | 3  |
| C | 40 | 2  | 3  |
| D | 1  | 30 | 8  |
| E | 3  | 39 | 3  |
| F | 5  | 7  | 4  |
| G | 8  | 5  | 1  |

Addition  
and  
Subtraction

Sumar  
y  
Restar

$$\square - \frac{43}{15} \bigcirc$$

$$\square - \frac{50}{10} \bigcirc$$

$$\square - \frac{23}{7} \bigcirc$$

$$\square - \frac{37}{3} \bigcirc$$

$$\square - \frac{43}{27} \bigcirc$$

$$\square - \frac{50}{12} \bigcirc$$

$$\square - \frac{23}{13} \bigcirc$$

$$\square - \frac{37}{13} \bigcirc$$

$$\square - \frac{43}{9} \bigcirc$$

$$\square - \frac{50}{2} \bigcirc$$

$$\square - \frac{23}{3} \bigcirc$$

$$\square - \frac{37}{25} \bigcirc$$

$$\square - \frac{43}{3} \bigcirc$$

$$\square - \frac{50}{34} \bigcirc$$

$$\begin{array}{r} 312 \\ 312 \\ + 312 \\ \hline \end{array} \text{A}$$

$$\begin{array}{r} 468 \\ 468 \\ + 468 \\ \hline \end{array} \text{B}$$

$$\begin{array}{r} 1,425 \\ 1,425 \\ + 1,425 \\ \hline \end{array} \text{C}$$

$$\begin{array}{r} 72,416 \\ 72,416 \\ + 72,416 \\ \hline \end{array} \text{D}$$

$$\begin{array}{r} 234 \\ 234 \\ + 234 \\ \hline \end{array} \text{A}$$

$$\begin{array}{r} 957 \\ 957 \\ + 957 \\ \hline \end{array} \text{B}$$

$$\begin{array}{r} 8239 \\ 8239 \\ + 8239 \\ \hline \end{array} \text{C}$$

$$\begin{array}{r} 98236 \\ 98236 \\ + 98236 \\ \hline \end{array} \text{D}$$

|   |   |   |   |   |
|---|---|---|---|---|
| $\begin{array}{r} 25 \\ \times 1 \\ \hline \end{array}$ | $\begin{array}{r} 25 \\ \times 2 \\ \hline \end{array}$ | $\begin{array}{r} 25 \\ \times 4 \\ \hline \end{array}$ | $\begin{array}{r} 25 \\ \times 7 \\ \hline \end{array}$ | $\begin{array}{r} 25 \\ \times 8 \\ \hline \end{array}$ |
|---|---|---|---|---|

D E F G

|  |  |  |  |  |
|--|--|--|--|--|
| $\begin{array}{r} 25 \\ \times 20 \\ \hline \end{array}$ | $\begin{array}{r} 25 \\ \times 30 \\ \hline \end{array}$ | $\begin{array}{r} 25 \\ \times 50 \\ \hline \end{array}$ | $\begin{array}{r} 25 \\ \times 60 \\ \hline \end{array}$ | $\begin{array}{r} 25 \\ \times 90 \\ \hline \end{array}$ |
|--|--|--|--|--|

C D E F G

$$3 \overline{) 174} \text{E}$$

$$7 \overline{) 1827} \text{F}$$

$$8 \overline{) 1656} \text{G}$$

$$25 \overline{) 925} \text{E}$$

$$25 \overline{) 1300} \text{F}$$

$$25 \overline{) 2425} \text{G}$$

|   | H     | I                 | J                | K                 |
|---|-------|-------------------|------------------|-------------------|
| A | 902   | 842               | 936              | 702               |
| B | 2871  | 1,404             | 2,173            | 1,324             |
| C | 4,275 | 500               | $\frac{24}{717}$ | 3,695             |
| D | 750   | $\frac{294}{708}$ | 50               | $\frac{217}{248}$ |
| E | 100   | 58                | 1,250            | 37                |
| F | 261   | 1,500             | 175              | 52                |
| G | 200   | 97                | 207              | 2,250             |

CHAIN REACTIONS

REACCIÓN EN CADENA

40  $\div 8$   $\overset{5}{-}$   $\times 6$  30  $\div 2$   $\overset{15}{-}$   $\div 3$   $\times 3$   $\div 3$   $\times 3$   $\div 5$   $\div 3$  3

36  $\div 4$   $\times 8$   $\div 2$   $\div 6$   $\times 7$   $\div 2$   $\div 3$   $\times 8$   $\div 2$   $\div 4$  7

7  $\times 2$   $\times 2$   $\div 7$   $\times 9$   $\div 3$   $\div 3$   $\times 2$   $\times 5$   $\div 2$   $\div 4$  5

63  $\div 3$   $\div 3$   $\times 2$   $\times 3$   $\div 2$   $\div 7$   $\times 3$   $\times 5$   $\div 3$   $\div 3$  5

D  
K  
F  
H

Please use the smallest whole numbers

Favor de usar los números más pequeños

|                                  |                              |                          |
|----------------------------------|------------------------------|--------------------------|
| 16   8   4   2   1   <u>7</u> F  | 27   9   3   1   <u>25</u> A | 25   5   1   <u>48</u> I |
| 16   8   4   2   1   <u>14</u> J | 27   9   3   1   <u>50</u> A | 25   5   1   <u>67</u> F |
| 16   8   4   2   1   <u>23</u> K | 27   9   3   1   <u>69</u> A | 25   5   1   <u>98</u> I |

$\frac{1}{3}$  of 24 = ---- B

$\frac{1}{2}$  x 24 = ---- C

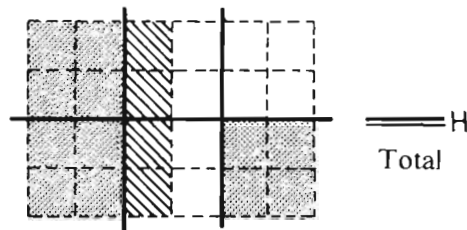

$\frac{1}{6}$  x 24 = ---- I     $\frac{5}{6}$  x 24 = ---- I     $\frac{6}{6}$  x 24 = ---- J

$\frac{1}{4}$  x 24 = ---- J

$\frac{2}{3}$  x 24 = ---- D

$\frac{3}{4}$  x 24 = ---- E

|                                      |                                      |
|--------------------------------------|--------------------------------------|
| $\frac{1}{3} + \frac{1}{3} =$ ---- B | $\frac{3}{4} - \frac{1}{2} =$ ---- K |
| $\frac{1}{2} + \frac{1}{4} =$ ---- C | $\frac{5}{6} - \frac{1}{3} =$ ----   |
| $\frac{1}{6} + \frac{1}{3} =$ ----   | $\frac{5}{6} - \frac{1}{2} =$ ---- C |

|   | H                          | I       | J       | K             |
|---|----------------------------|---------|---------|---------------|
| A | 2,2,2,1                    | 0,2,2,1 | 2,1,2,0 | 1,2,1,2       |
| B | $\frac{2}{3}$              | 8       | 6       | $\frac{1}{4}$ |
| C | $\frac{1}{3}, \frac{2}{6}$ | 4       | 12      | $\frac{3}{4}$ |
| D | 17                         | 20      | 16      | 5             |
| E | 42                         | 18      | 24      | 6             |
| F | 36                         | 3,4,3   | 0,0,1,1 | 2,3,2         |
| G | 24                         | 1,4,3   | 0,1,1,0 | 1,0,1,1       |

Please use the "smallest numbers" under the arrows

Favor de usar "los números más pequeños" debajo de las flechas.

$$\begin{array}{|c|c|} \hline 2 & \\ \hline 9 & 4 \\ \hline \end{array} + \begin{array}{r} 36 \\ \hline 48 \\ \hline \end{array}$$

B

$$\begin{array}{|c|c|} \hline 3 & \\ \hline 8 & \\ \hline \end{array} + \begin{array}{r} \\ \hline 45 \\ \hline \end{array}$$

C

$$\begin{array}{|c|c|} \hline 4 & \\ \hline 7 & \\ \hline \end{array} \begin{array}{r} \\ \hline 59 \\ \hline \end{array}$$

D

$$\begin{array}{|c|c|} \hline 5 & \\ \hline 6 & \\ \hline \end{array} \begin{array}{r} \\ \hline 33 \\ \hline \end{array}$$

E

$$\begin{array}{|c|c|} \hline 2 & \\ \hline 9 & \\ \hline \end{array} + \begin{array}{r} \\ \hline 41 \\ \hline \end{array}$$

C

$$\begin{array}{|c|c|} \hline 3 & \\ \hline 8 & \\ \hline \end{array} \begin{array}{r} \\ \hline 47 \\ \hline \end{array}$$

B

$$\begin{array}{|c|c|} \hline 4 & \\ \hline 7 & \\ \hline \end{array} \begin{array}{r} \\ \hline 52 \\ \hline \end{array}$$

D

$$\begin{array}{|c|c|} \hline 5 & \\ \hline 6 & \\ \hline \end{array} \begin{array}{r} \\ \hline 43 \\ \hline \end{array}$$

E

**TWO-WAY Chain Reactions**

**Reacción en Cadena en DOS MANERAS.**

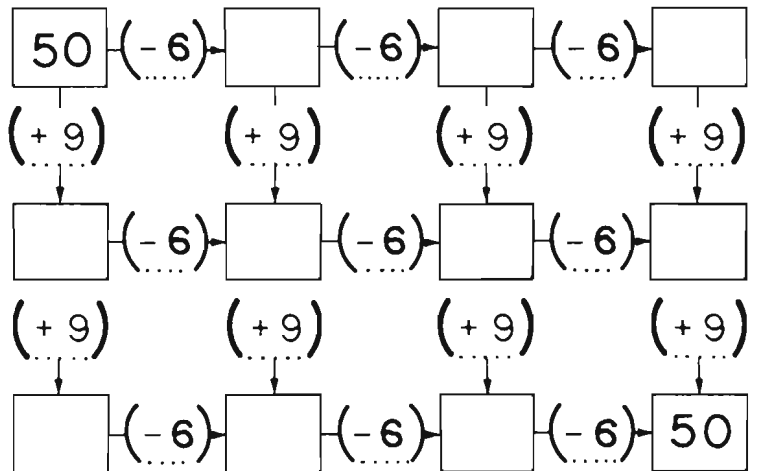
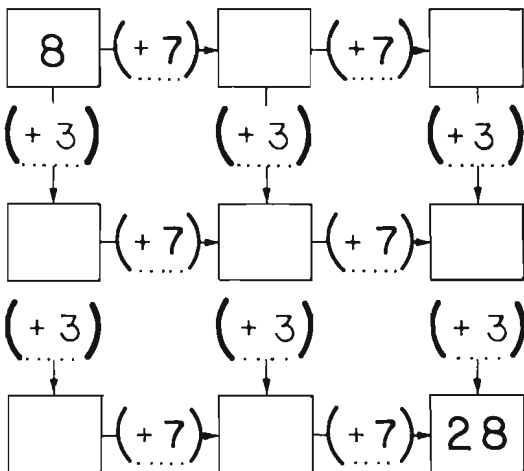

|  |  |   |   |   |
|--|--|---|---|---|
| $\begin{array}{r} 18 \\ \times 1 \\ \hline 18 \end{array}$ | $\begin{array}{r} 18 \\ \times 2 \\ \hline 36 \end{array}$ | $\begin{array}{r} 18 \\ \times 4 \\ \hline \end{array}$ | $\begin{array}{r} 18 \\ \times 7 \\ \hline \end{array}$ | $\begin{array}{r} 18 \\ \times 8 \\ \hline \end{array}$ |
| F  | G  | I   |   |   |

|  |  |  |  |  |
|--|--|--|--|--|
| $\begin{array}{r} 18 \\ \times 20 \\ \hline 360 \end{array}$ | $\begin{array}{r} 18 \\ \times 30 \\ \hline \end{array}$ | $\begin{array}{r} 18 \\ \times 50 \\ \hline \end{array}$ | $\begin{array}{r} 18 \\ \times 60 \\ \hline \end{array}$ | $\begin{array}{r} 18 \\ \times 90 \\ \hline \end{array}$ |
| K  | F  | G  | H  |  |

$$\begin{array}{r} 18 \\ \times 21 \\ \hline 360 \end{array}$$

H

$$\begin{array}{r} 18 \\ \times 38 \\ \hline \end{array}$$

J

$$\begin{array}{r} 18 \\ \times 52 \\ \hline \end{array}$$

D

$$\begin{array}{r} 18 \\ \times 96 \\ \hline \end{array}$$

E

$$\begin{array}{r} 18 \\ \times 57 \\ \hline \end{array}$$

D

$$\begin{array}{r} 18 \\ \times 64 \\ \hline \end{array}$$

H

|   | H     | I   | J     | K   |
|---|-------|-----|-------|-----|
| A | 880   | 7,2 | 420   | 6,5 |
| B | 4,4   | 6,4 | 486   | 5,4 |
| C | 378   | 5,4 | 684   | 7,3 |
| D | 1,026 | 6,5 | 936   | 6,4 |
| E | 1,152 | 5,3 | 1,728 | 3,3 |
| F | 1,620 | 7,2 | 410   | 900 |
| G | 1,080 | 144 | 126   | 540 |

Loop Arithmetic

3 3 3 (17)<sup>E</sup>

5 5 5 5 (47)<sup>F</sup>

4 4 4 4 (25)<sup>F</sup>

Aritmética de lazo

4 4 4

8 8 8 8

9 9 9 9

5 5 5 (32)<sup>G</sup>  
9 9 9

8 8 8 (31)<sup>A</sup>  
5 5 5

7 7 7 7 (34)<sup>K</sup>  
3 3 3 3

6 6 6 6 (38)<sup>J</sup>  
7 7 7 7

4 4 4 (19)<sup>H</sup>  
7 7 7

6 6 6 (22)<sup>I</sup>  
5 5 5

2 2 2 2 (26)<sup>A</sup>  
9 9 9 9

3 3 3 3 (41)<sup>G</sup>  
8 8 8 8

Please extend the patterns

Favor de extender las muestras.

0 1 1 2 3 5 8 A \_\_\_\_\_ 89 233

5 11 17 23 B \_\_\_\_\_ 59 83

5 12 19 G 33 \_\_\_\_\_ 61 75 96

5 13 21 H \_\_\_\_\_ 45 61 \_\_\_\_\_ 93 109

5 14 23 I \_\_\_\_\_ 59 \_\_\_\_\_ 122

$\frac{1}{2}$  of 36 = ---- B

$\frac{1}{3}$  x 36 = ---- K

$\frac{1}{4}$  x 36 = ---- C

$\frac{1}{6}$  x 36 = ---- D

$\frac{1}{9}$  x 36 = ---- J

$\frac{2}{3}$  x 36 = ---- K

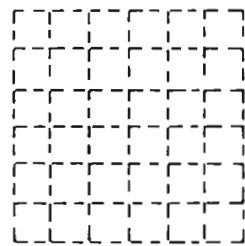

==== I  
Total

$\frac{3}{4}$  x 36 = ---- C

$\frac{5}{9}$  x 36 = ---- D

|  |  |
|--|--|
| $\frac{1}{4} + \frac{1}{2} = \text{---}$ | $\frac{1}{3} - \frac{1}{6} = \text{---}$ |
| $\frac{1}{3} + \frac{1}{6} = \text{---}$ | $\frac{2}{3} - \frac{1}{3} = \text{---}$ |
| $\frac{1}{6} + \frac{1}{6} = \text{---}$ | $\frac{5}{9} - \frac{4}{9} = \text{---}$ |

|   | H               | I                  | J                 | K                 |
|---|-----------------|--------------------|-------------------|-------------------|
| A | 13              | 32                 | $\frac{88}{555}$  | $\frac{2222}{99}$ |
| B | 29              | 36                 | 18                | 24                |
| C | 41              | 27                 | 9                 | 12                |
| D | 53              | 20                 | 4                 | 6                 |
| E | 9               | $\frac{66}{55}$    | $\frac{333}{44}$  | $\frac{7777}{33}$ |
| F | $\frac{444}{7}$ | $\frac{555}{8888}$ | $\frac{6666}{77}$ | $\frac{4444}{9}$  |
| G | 26              | $\frac{333}{8888}$ | $\frac{5}{999}$   | $\frac{777}{888}$ |



16's

|    |   |   |   |   |
|----|---|---|---|---|
| 5  | 2 | 2 | 4 | 3 |
| 11 | 3 | 7 | 2 | 7 |
| 2  | 9 | 3 | 4 | 5 |
| 5  | 4 | 4 | 4 | 5 |
| 8  | 3 | 4 | 5 | 1 |

17's

|   |   |   |    |   |
|---|---|---|----|---|
| 2 | 4 | 3 | 5  | 6 |
| 9 | 7 | 9 | 5  | 6 |
| 6 | 6 | 8 | 2  | 3 |
| 1 | 8 | 9 | 10 | 4 |
| 8 | 6 | 2 | 2  | 5 |

18's

|   |   |   |   |   |
|---|---|---|---|---|
| 5 | 6 | 6 | 9 | 9 |
| 6 | 6 | 7 | 2 | 4 |
| 3 | 4 | 8 | 8 | 5 |
| 7 | 6 | 8 | 2 | 7 |
| 8 | 3 | 4 | 9 | 2 |

DOMINO PUZZLES

ROMPECABEZAS DE DOMINOS

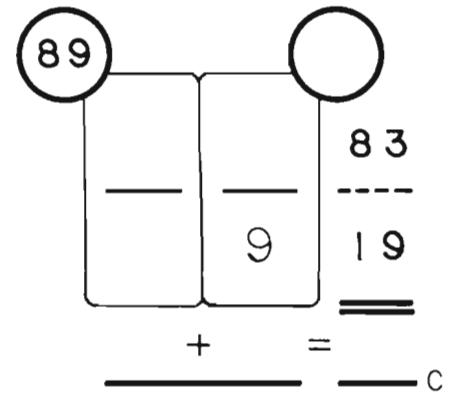
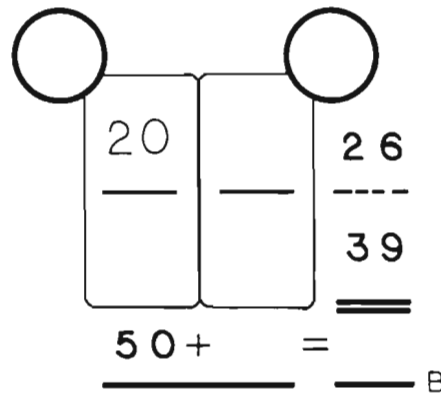
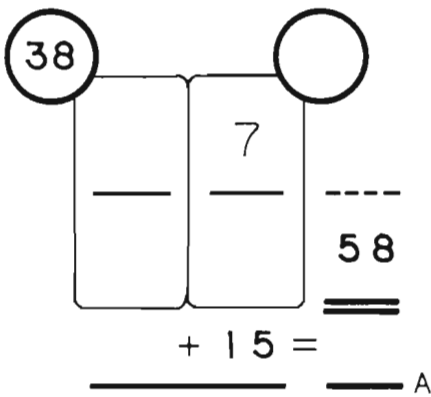

|   |   |   |   |   |
|---|---|---|---|---|
| $\begin{array}{r} 37 \\ \times 1 \\ \hline \end{array}$ | $\begin{array}{r} 37 \\ \times 2 \\ \hline \end{array}$ | $\begin{array}{r} 37 \\ \times 4 \\ \hline \end{array}$ | $\begin{array}{r} 37 \\ \times 7 \\ \hline \end{array}$ | $\begin{array}{r} 37 \\ \times 8 \\ \hline \end{array}$ |
| H   | K   | I   | C   | H   |

|  |  |  |  |  |
|--|--|--|--|--|
| $\begin{array}{r} 37 \\ \times 20 \\ \hline \end{array}$ | $\begin{array}{r} 37 \\ \times 30 \\ \hline \end{array}$ | $\begin{array}{r} 37 \\ \times 50 \\ \hline \end{array}$ | $\begin{array}{r} 37 \\ \times 60 \\ \hline \end{array}$ | $\begin{array}{r} 37 \\ \times 90 \\ \hline \end{array}$ |
| E  |  |  |  |  |

$$\begin{array}{r} 37 \\ \times 51 \\ \hline \end{array} \quad D$$

$$\begin{array}{r} 37 \\ \times 18 \\ \hline \end{array} \quad E$$

$$\begin{array}{r} 37 \\ \times 23 \\ \hline \end{array} \quad F$$

$$\begin{array}{r} 37 \\ \times 62 \\ \hline \end{array} \quad G$$

$$\begin{array}{r} 37 \\ \times 37 \\ \hline \end{array} \quad J$$

$$\begin{array}{r} 37 \\ \times 94 \\ \hline \end{array} \quad D$$

|   | H     | I     | J     | K     |
|---|-------|-------|-------|-------|
| A | 95    | 85    | 106   | 74    |
| B | 37    | 75    | 65    | 83    |
| C | 296   | 148   | 102   | 259   |
| D | 2,567 | 3,478 | 1,887 | 2,918 |
| E | 1,111 | 740   | 666   | 1,578 |
| F | 2,245 | 851   | 1,369 | 1,001 |
| G | 849   | 2,294 | 2,174 | 643   |

$$\begin{array}{r} 1,166 \\ + 108 \\ \hline \end{array}$$

$$\begin{array}{r} 166 \\ + 783 \\ \hline \end{array}$$

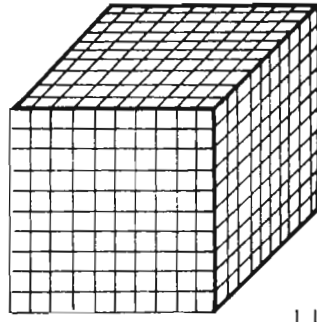

$$\begin{array}{r} 1,166 \\ - 159 \\ \hline \end{array}$$

$$\begin{array}{r} 1,166 \\ - 77 \\ \hline \end{array}$$

$$\begin{array}{r} 1,083 \\ + 83 \\ \hline \end{array}$$

$$\begin{array}{r} 1,166 \\ + 1,999 \\ \hline \end{array}$$

1,166

$$\begin{array}{r} 2,166 \\ - 729 \\ \hline \end{array}$$

$$\begin{array}{r} 7,166 \\ - 1,598 \\ \hline \end{array}$$

$$\begin{array}{r} 166 \\ 166 \\ 166 \\ + 166 \\ \hline \end{array}$$

$$\begin{array}{r} 367 \\ 82 \\ 197 \\ + 56 \\ \hline \end{array}$$

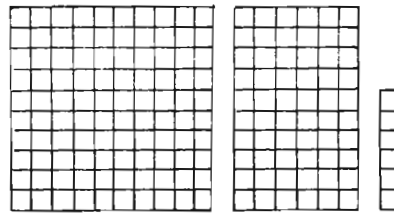

$$\begin{array}{r} 1,166 \\ \div 2 \\ \hline \end{array}$$

$$\begin{array}{r} 1,166 \\ \times 2 \\ \hline \end{array}$$

|   |   |   |   |   |   |   |   |  |  |   |  |  |  |
|---|---|---|---|---|---|---|---|--|--|---|--|--|--|
| $\begin{array}{r} 13 \\ \times 2 \\ \hline \end{array}$ | $\begin{array}{r} 13 \\ \times 3 \\ \hline \end{array}$ | $\begin{array}{r} 13 \\ \times 4 \\ \hline \end{array}$ | $\begin{array}{r} 13 \\ \times 5 \\ \hline \end{array}$ | $\begin{array}{r} 13 \\ \times 6 \\ \hline \end{array}$ | $\begin{array}{r} 13 \\ \times 7 \\ \hline \end{array}$ | $\begin{array}{r} 13 \\ \times 8 \\ \hline \end{array}$ | $\begin{array}{r} 13 \\ \times 9 \\ \hline \end{array}$ | $\begin{array}{r} 13 \\ \times 10 \\ \hline \end{array}$ | $\begin{array}{r} 13 \\ \times 20 \\ \hline \end{array}$ | $\begin{array}{r} 30 \\ \hline \end{array}$ | $\begin{array}{r} 13 \\ \times 40 \\ \hline \end{array}$ | $\begin{array}{r} 13 \\ \times 50 \\ \hline \end{array}$ | $\begin{array}{r} 13 \\ \times 60 \\ \hline \end{array}$ |
|---|---|---|---|---|---|---|---|--|--|---|--|--|--|

$$\begin{array}{r} 13 \\ \times 49 \\ \hline \end{array}$$

$$\begin{array}{r} 13 \\ \times 25 \\ \hline \end{array}$$

$$\begin{array}{r} 13 \\ \times 67 \\ \hline \end{array}$$

$$\begin{array}{r} 13 \\ \times 58 \\ \hline \end{array}$$

|  |  |  |  |
|--|--|--|--|
| $\begin{array}{r} R \\ 6 \overline{)45} \end{array}$ | $\begin{array}{r} R \\ 7 \overline{)50} \end{array}$ | $\begin{array}{r} R \\ 8 \overline{)60} \end{array}$ | $\begin{array}{r} R \\ 9 \overline{)75} \end{array}$ |
| $\begin{array}{r} R \\ 6 \overline{)65} \end{array}$ | $\begin{array}{r} R \\ 7 \overline{)67} \end{array}$ | $\begin{array}{r} R \\ 8 \overline{)75} \end{array}$ | $\begin{array}{r} R \\ 9 \overline{)50} \end{array}$ |
| $\begin{array}{r} R \\ 6 \overline{)33} \end{array}$ | $\begin{array}{r} R \\ 7 \overline{)57} \end{array}$ | $\begin{array}{r} R \\ 8 \overline{)65} \end{array}$ | $\begin{array}{r} R \\ 9 \overline{)85} \end{array}$ |

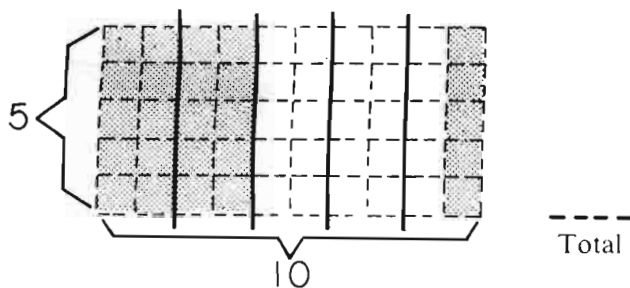

$$\frac{2}{5} \text{ of } \underline{50} = \text{-----}$$

$$\frac{1}{2} \times \underline{50} = \text{-----}$$

$$\frac{1}{10} \times \underline{50} = \text{-----}$$

$$\frac{1}{10} + \frac{2}{5} = \text{-----}$$

$$N = 2 \frac{1}{2} \phi$$

1 Hr...150miles

| N   | total   |
|-----|---------|
| 4¢  | 10¢     |
| 10¢ | ¢       |
|     | 90¢     |
|     | \$ 1.50 |
| 50¢ | \$      |

| Hrs.             | miles |
|------------------|-------|
| $\frac{1}{2}$    | 75    |
| $\frac{1}{5}$    |       |
| $1 \frac{1}{10}$ |       |



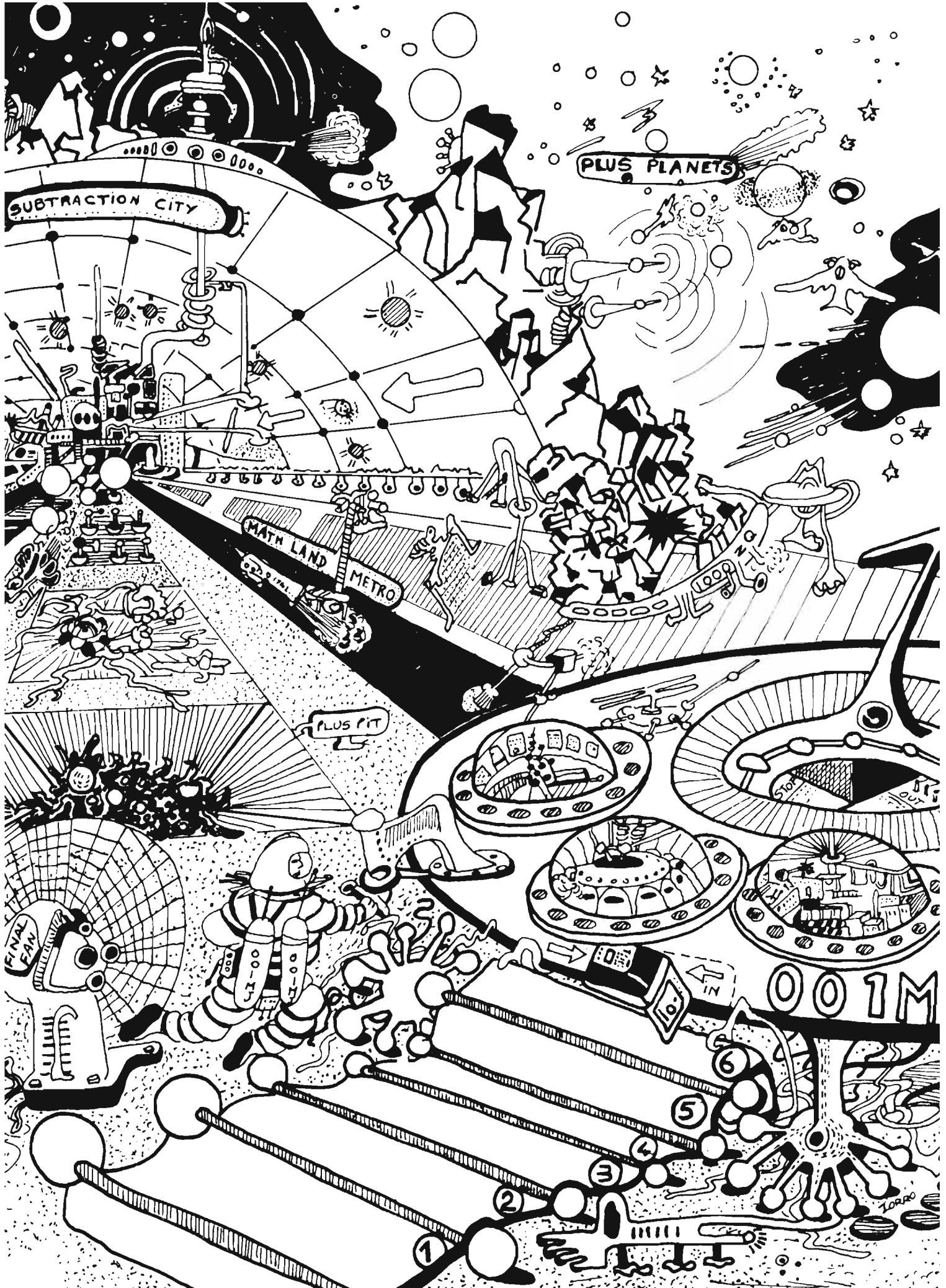

his  
book  
belongs  
to

este  
libro  
es de

